

## Serial Infrared Transceiver SIR, 115.2 kbit/s, 2.7 V to 5.5 V Operation



### Description

The TFBS4711 is a low profile, Infrared Data Transceiver module. It supports IrDA data rates up to 115.2 kbit/s (SIR). The transceiver module consists of a PIN photodiode, an infrared emitter (IRED), and a low-power CMOS control IC to provide a total front-end solution in a single package.

The device is designed for the low power IrDA standard with an extended range on-axis up to 1 m. The RXD pulse width is independent of the duration of TXD pulse and always stays at a fixed width thus making the device optimum for all standard SIR Encoder/ Decoder and interfaces. The Shut Down (SD) feature cuts current consumption to typically 10 nA.



### Features

- Compliant with the latest IrDA physical layer low power specification (9.6 kbit/s to 115.2 kbit/s)
- Small package:  
H 1.9 mm x D 3.1 mm x L 6.0 mm
- Industries smallest footprint  
- 6.0 mm length  
- 1.9 mm height
- Typical Link distance on-axis up to 1 m
- Battery & power management features:  
> Idle Current - 75  $\mu$ A Typical  
> Shutdown current - 10 nA typical  
> Operates from 2.4 V - 5.5 V within specification over full temperature range from - 25 °C to + 85 °C
- Remote Control - transmit distance up to 8 meters



- Tri-State receiver output, floating in shutdown with a weak pull-up
- Constant RXD output pulse width (2  $\mu$ s typical)
- Meets IrFM Fast Connection requirements
- Split power supply, an independent, unregulated supply for IRED Anode and a well regulated supply for  $V_{CC}$
- Directly interfaces with various Super I/O and Controller Devices and Encoder/ Decoder such as TOIM4232
- Lead (Pb)-free device
- Qualified for lead (Pb)-free and Sn/Pb processing (MSL4)
- Device in accordance with RoHS 2002/95/EC and WEEE 2002/96EC

### Applications

- Ideal for battery operated devices
- PDAs
- Mobile phones
- Electronic wallet (IrFM)
- Notebook computers
- Digital still and video cameras
- Printers, fax machines, photocopiers, screen projectors
- Data loggers
- External infrared adapters (Dongles)
- Diagnostics systems
- Medical and industrial data collection devices
- Kiosks, POS, Point and Pay devices
- GPS
- Access control
- Field programming devices

### Parts Table

Part	Description	Qty/Reel
TFBS4711-TR1	Oriented in carrier tape for side view surface mounting	1000 pcs
TFBS4711-TR3	Oriented in carrier tape for side view surface mounting	2500 pcs
TFBS4711-TT1	Oriented in carrier tape for top view surface mounting	1000 pcs

Functional Block Diagram

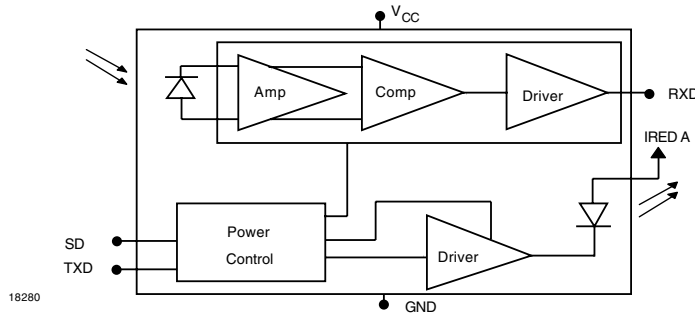

Pinout

TFBS4711  
weight 50 mg

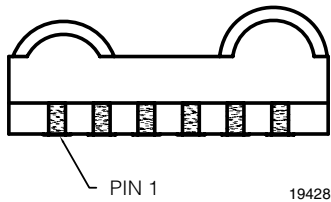

Definitions:

In the Vishay transceiver data sheets the following nomenclature is used for defining the IrDA operating modes:

SIR: 2.4 kbit/s to 115.2 kbit/s, equivalent to the basic serial infrared standard with the physical layer version IrPhy 1.0

MIR: 576 kbit/s to 1152 kbit/s

FIR: 4 Mbit/s

VFIR: 16 Mbit/s

MIR and FIR were implemented with IrPhy 1.1, followed by IrPhy 1.2, adding the SIR Low Power Standard.

Pin Description

Pin Number	Function	Description	I/O	Active
1	IRED Anode	IRED Anode is directly connected to a power supply. The LED current can be decreased by adding a resistor in series between the power supply and IRED Anode. A separate unregulated power supply can be used at this pin.		
2	TXD	This Input is used to turn on IRED transmitter when SD is low. An on-chip protection circuit disables the LED driver if the TXD pin is asserted for longer than 80 $\mu$ s	I	HIGH
3	RXD	Received Data Output, normally stays high but goes low for a fixed duration during received pulses. It is capable of driving a standard CMOS or TTL load.	O	LOW
4	SD	Shutdown. Setting this pin active switches the device into shutdown mode	I	HIGH
5	V <sub>CC</sub>	Supply Voltage		
6	GND	Ground		

Absolute Maximum Ratings

Reference Point Ground, Pin 6 unless otherwise noted.

Parameter	Test Conditions	Symbol	Min	Typ.	Max	Unit
Supply voltage range, all states		V <sub>CC</sub>	- 0.5		+ 6.0	V
Input current	For all Pins except IRED Anode Pin	I <sub>CC</sub>			10.0	mA
Output sink current, RXD					25.0	mA
Average output current, pin 1	20 % duty cycle	I <sub>IRED (DC)</sub>			80	mA
Repetitive pulsed output current	< 90 $\mu$ s, t <sub>on</sub> < 20 %	I <sub>IRED (RP)</sub>			400	mA
IRED anode voltage, pin 1		V <sub>IRED A</sub>	- 0.5		+ 6.0	V
Voltage at all inputs and outputs	V <sub>in</sub> > V <sub>CC</sub> is allowed	V <sub>IN</sub>	- 0.5		+ 6.0	V
Ambient temperature range (operating)		T <sub>amb</sub>	- 30		+ 85	°C
Storage temperature range		T <sub>stg</sub>	- 40		+ 100	°C
Soldering temperature	See Recommended Solder Profile				260	°C

### Eye safety information

Parameter	Test Conditions	Symbol	Min	Typ.	Max	Unit
Virtual source size	Method: (1-1/e) encircled energy	d	1.3	1.5		mm
Maximum intensity for class 1	IEC60825-1 or EN60825-1, edition Jan. 2001, operating below the absolute maximum ratings	$I_e$			<sup>*)</sup> (500 <sup>**)</sup>	mW/sr

### Electrical Characteristics

#### Transceiver

$T_{amb} = 25\text{ }^{\circ}\text{C}$ ,  $V_{CC} = V_{IREDA} = 2.4\text{ V to }5.5\text{ V}$  unless otherwise noted.

Parameter	Test Conditions	Symbol	Min	Typ.	Max	Unit
Supply voltage range, all states		$V_{CC}$	2.4		5.5	V
Idle supply current at $V_{CC1}$ (receive mode, no signal)	SD = Low, $E_e = 1\text{ klx}^*)$ , $T_{amb} = -25\text{ }^{\circ}\text{C to }+85\text{ }^{\circ}\text{C}$ , $V_{CC} = 2.7\text{ V to }5.5\text{ V}$	$I_{CC1}$			130	$\mu\text{A}$
	SD = Low, $E_e = 1\text{ klx}^*)$ , $T_{amb} = 25\text{ }^{\circ}\text{C}$ , $V_{CC} = 2.7\text{ V to }5.5\text{ V}$	$I_{CC1}$		75		$\mu\text{A}$
Receive current	$V_{CC} = 2.7\text{ V}$	$I_{CC}$		80		$\mu\text{A}$
Shutdown current	SD = High, $T = 25\text{ }^{\circ}\text{C}$ , $E_e = 0\text{ klx}$	$I_{SD}$		< 0.1	2	$\mu\text{A}$
	SD = High, $T = 85\text{ }^{\circ}\text{C}$	$I_{SD}$			3	$\mu\text{A}$
Operating temperature range		$T_A$	- 25		+ 85	$^{\circ}\text{C}$
Output voltage low, RXD	$I_{OL} = 1\text{ mA}$	$V_{OL}$	- 0.5		$0.15 \times V_{CC}$	V
Output voltage high, RXD	$I_{OH} = -500\text{ }\mu\text{A}$	$V_{OH}$	$0.8 \times V_{CC}$		$V_{CC} + 0.5$	V
	$I_{OH} = -250\text{ }\mu\text{A}$	$V_{OH}$	$0.9 \times V_{CC}$		$V_{CC} + 0.5$	V
RXD to $V_{CC}$ impedance		$R_{RXD}$	400	500	600	$\text{k}\Omega$
Input voltage low: TXD, SD		$V_{IL}$	- 0.5		0.5	V
Input voltage high: TXD, SD	CMOS level ( $0.5 \times V_{CC}$ typ, threshold level)	$V_{IH}$	$V_{CC} - 0.5$		6.0	V
Input leakage current (TXD, SD)	$V_{in} = 0.9 \times V_{CC}$	$I_{ICH}$	- 2		+ 2	$\mu\text{A}$
Controlled pull down current	SD, TXD = "0" or "1", $0 < V_{in} < 0.15 V_{CC}$	$I_{IRTX}$			+ 150	$\mu\text{A}$
	SD, TXD = "0" or "1" $V_{in} > 0.7 V_{CC}$	$I_{IRTX}$	- 1	0	1	$\mu\text{A}$
Input capacitance		$C_{IN}$			5	pF

### Optoelectronic Characteristics

#### Receiver

$T_{amb} = 25\text{ }^{\circ}\text{C}$ ,  $V_{CC} = 2.4\text{ V}$  to  $5.5\text{ V}$  unless otherwise noted

Parameter	Test Conditions	Symbol	Min	Typ.	Max	Unit
Minimum irradiance $E_e$ in angular range **)	9.6 kbit/s to 115.2 kbit/s $\lambda = 850\text{ nm} - 900\text{ nm}$ , $\alpha = 0^{\circ}, 15^{\circ}$	$E_e$		35 (3.5)	80 (8)	$\text{mW}/\text{m}^2$ ( $\mu\text{W}/\text{cm}^2$ )
Maximum irradiance $E_e$ in angular range***)	$\lambda = 850\text{ nm} - 900\text{ nm}$	$E_e$		5 (500)		$\text{kW}/\text{m}^2$ ( $\text{mW}/\text{cm}^2$ )
Maximum no detection irradiance		$E_e$	4 (0.4)			$\text{mW}/\text{m}^2$ ( $\mu\text{W}/\text{cm}^2$ )
Rise time of output signal	10 % to 90 %, $C_L = 15\text{ pF}$	$t_{r(\text{RXD})}$	10		100	ns
Fall time of output signal	90 % to 10 %, $C_L = 15\text{ pF}$	$t_{f(\text{RXD})}$	10		100	ns
RXD pulse width	Input pulse width $> 1.2\text{ }\mu\text{s}$	$t_{\text{PW}}$	1.7	2.0	3.0	$\mu\text{s}$
Leading edge jitter	Input Irradiance = $100\text{ mW}/\text{m}^2$ , $\leq 115.2\text{ kbit/s}$				250	ns
Standby /Shutdown delay, receiver startup time	After shutdown active or power-on				150	$\mu\text{s}$
Latency		$t_L$			150	$\mu\text{s}$

\*\*\*) IrDA sensitivity definition: **Minimum Irradiance  $E_e$  In Angular Range**, power per unit area. The receiver must meet the BER specification while the source is operating at the minimum intensity in angular range into the minimum half-angle range at the maximum Link Length.

\*\*\*\*) **Maximum Irradiance  $E_e$  In Angular Range**, power per unit area. The optical delivered to the detector by a source operating at the maximum intensity in angular range at Minimum Link Length must not cause receiver overdrive distortion and possible related link errors. If placed at the Active Output Interface reference plane of the transmitter, the receiver must meet its bit error ratio (BER). For more definitions see the document "Symbols and Terminology" on the Vishay Website (<http://www.vishay.com/docs/82512/82512.pdf>).

#### Transmitter

$T_{amb} = 25\text{ }^{\circ}\text{C}$ ,  $V_{CC} = 2.4\text{ V}$  to  $5.5\text{ V}$  unless otherwise noted.

Parameter	Test Conditions	Symbol	Min	Typ.	Max	Unit
IRED operating current	$T_{amb} = -25\text{ }^{\circ}\text{C}$ to $+85\text{ }^{\circ}\text{C}$	$I_D$	200	300	400	mA
Transceiver operating peak supply current	During pulsed IRED operation at $I_D = 300\text{ mA}$	$I_{CC}$		0.57		mA
IRED leakage current	$\text{TXD} = 0\text{ V}$ , $0 < V_{CC} < 5.5\text{ V}$	$I_{\text{IRED}}$	- 1		1	$\mu\text{A}$
Output radiant intensity	$\alpha = 0^{\circ}$ , $\text{TXD} = \text{High}$ , $\text{SD} = \text{Low}$ , $R = 0\text{ }\Omega$ , $V_{\text{LED}} = 2.4\text{ V}$	$I_e$	45	60	300	$\text{mW}/\text{sr}$
	$\alpha = 0^{\circ}, 15^{\circ}$ , $\text{TXD} = \text{High}$ , $\text{SD} = \text{Low}$ , $R = 0\text{ }\Omega$ , $V_{\text{LED}} = 2.4\text{ V}$	$I_e$	25	35	300	$\text{mW}/\text{sr}$
	$V_{CC} = 5.0\text{ V}$ , $\alpha = 0^{\circ}, 15^{\circ}$ , $\text{TXD} = \text{High}$ or $\text{SD} = \text{High}$ (Receiver is inactive as long as $\text{SD} = \text{High}$ )	$I_e$			0.04	$\text{mW}/\text{sr}$
Output radiant intensity, angle of half intensity		$\alpha$		$\pm 22$		$^{\circ}$
Peak-emission wavelength		$\lambda_p$	880		900	nm
Spectral bandwidth		$\Delta\lambda$		45		nm
Optical rise time		$t_{\text{ropt}}$	10		100	ns
Optical fall time		$t_{\text{fopt}}$	10		100	ns
Optical output pulse duration	Input pulse width $1.63\text{ }\mu\text{s}$ , $115.2\text{ kbit/s}$	$t_{\text{opt}}$	1.41	1.63	2.23	$\mu\text{s}$
	Input pulse width $t_{\text{TXD}} < 20\text{ }\mu\text{s}$	$t_{\text{opt}}$	$t_{\text{TXD}}$		$t_{\text{TXD}} + 0.15$	$\mu\text{s}$
	Input pulse width $t_{\text{TXD}} \geq 20\text{ }\mu\text{s}$	$t_{\text{opt}}$			300	$\mu\text{s}$
Optical overshoot					25	%

## Recommended Solder Profiles

### Solder Profile for Sn/Pb soldering

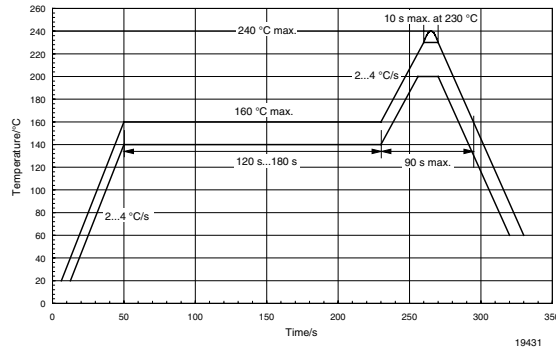

Figure 1. Recommended Solder Profile for Sn/Pb soldering

### Lead (Pb)-Free, Recommended Solder Profile

The TFBS4711 is a lead (Pb)-free transceiver and qualified for lead (Pb)-free processing. For lead (Pb)-free solder paste like Sn(3.0-4.0)Ag(0.5-0.9)Cu, there are two standard reflow profiles: Ramp-Soak-Spike (RSS) and Ramp-To-Spike (RTS). The Ramp-Soak-Spike profile was developed primarily for reflow ovens heated by infrared radiation. With widespread use of forced convection reflow ovens the Ramp-To-Spike profile is used increasingly. Shown below in figure 2 is VISHAY's recommended profiles for use with the TFBS4711 transceivers. For more details please refer to Application note: SMD Assembly Instruction.

### Wave Soldering

For TFDUxxxx and TFBSxxxx transceiver devices wave soldering is not recommended.

### Manual Soldering

Manual soldering is the standard method for lab use. However, for a production process it cannot be recommended because the risk of damage is highly dependent on the experience of the operator. Nevertheless, we added a chapter to the above mentioned application note, describing manual soldering and desoldering.

### Storage

The storage and drying processes for all VISHAY transceivers (TFDUxxxx and TFBSxxx) are equivalent to MSL4.

The data for the drying procedure is given on labels on the packing and also in the application note "Taping, Labeling, Storage and Packing"

(<http://www.vishay.com/docs/82601/82601.pdf>).

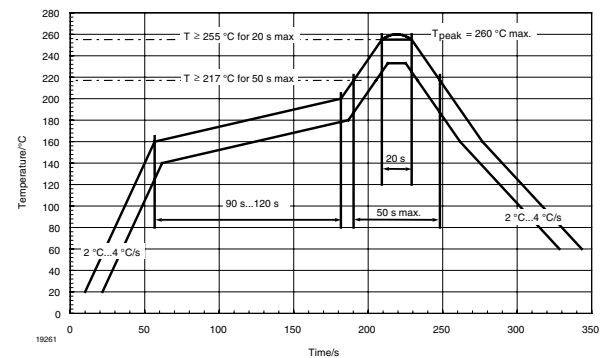

Figure 2. Solder Profile, RSS Recommendation

### Recommended Circuit Diagram

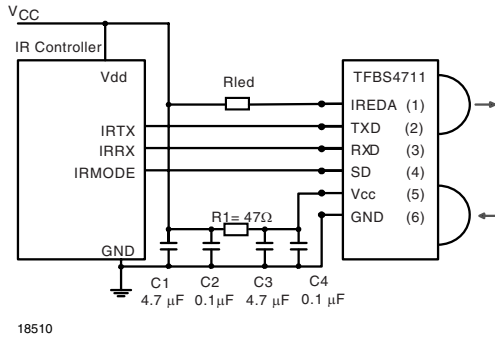

Figure 3. Recommended Application Circuit

Operated at a clean low impedance power supply the TFBS4711 needs no additional external components when the internal current control is used. For reducing the IRED drive current for low power applications with reduced range an additional resistor can be used to connect the IRED to the separate power supply. Depending on the entire system design and board layout, additional components may be required. (see figure 3).

Worst-case conditions are test set-ups with long cables to power supplies. In such a case capacitors are necessary to compensate the effect of the cable inductance. In case of small applications as e.g. mobile phones where the power supply is close to the transceiver big capacitors are normally not necessary. The capacitor C1 is buffering the supply voltage and eliminates the inductance of the power supply line. This one should be a small ceramic version or other fast capacitor to guarantee the fast rise time of the IRED current. The resistor R1 is optional for reducing the IRED drive current.

Vishay transceivers integrate a sensitive receiver and a built-in power driver. The combination of both needs a careful circuit board layout. The use of thin, long,

resistive and inductive wiring should be avoided. The inputs (TXD, SD) and the output RXD should be directly (DC) coupled to the I/O circuit

The capacitor C2 combined with the resistor R2 is the low pass filter for smoothing the supply voltage when noisy supply voltage is used or pick-up via the wiring is expected.

R2, C1 and C2 are optional and dependent on the quality of the supply voltage  $V_{CCX}$  and injected noise. An unstable power supply with dropping voltage during transmission may reduce the sensitivity (and transmission range) of the transceiver.

The placement of these parts is critical. It is strongly recommended to position C2 as close as possible to the transceiver power supply pins.

In any case, when connecting the described circuit to the power supply, low impedance wiring should be used.

When extended wiring is used the inductance of the power supply can cause dynamically a voltage drop at  $V_{CC2}$ . Often some power supplies are not to follow the fast current rise time. In that case another 10  $\mu\text{F}$  capacitor at  $V_{CC2}$  will be helpful.

The recommended components in table 1 are for test set-ups

Keep in mind that basic RF - design rules for circuit design should be taken into account. Especially longer signal lines should not be used without termination. See e.g. "The Art of Electronics" Paul Horowitz, Winfield Hill, 1989, Cambridge University Press, ISBN: 0521370957

### I/O and Software

In the description, already different I/Os are mentioned. Different combinations are tested and the function verified with the special drivers available from the I/O suppliers. In special cases refer to the I/O manual, the Vishay application notes, or contact directly Vishay Sales, Marketing or Application.

**Table 1.**  
**Recommended Application Circuit Components**

Component	Recommended Value	Vishay Part Number
C1, C3	4.7 $\mu\text{F}$ , 16 V	293D 475X9 016B
C2, C4	0.1 $\mu\text{F}$ , Ceramic	VJ 1206 Y 104 J XXMT
R1	47 $\Omega$ , 0.125 W	CRCW-1206-47R0-F-RT1

**Table 2.**  
**Truth table**

SD	TXD	Optical input Irradiance mW/m <sup>2</sup>	RXD	Transmitter	Operation
Inputs	Inputs	Inputs	Outputs	Outputs	Remark
high	x	x	weakly pulled (500 Ω) to V <sub>CC1</sub>	0	Shutdown
low	high	x	high inactive	I <sub>e</sub>	Transmitting
low	high > 300 μs	x	high inactive	0	Protection is active
low	low	< 4	high inactive	0	Ignoring low signals below the IrDA defined threshold for noise immunity
low	low	> Min. Detection Threshold Irradiance < Max. Detection Threshold Irradiance	low (active)	0	Response to an IrDA compliant optical input signal
low	low	> Max. Detection Threshold Irradiance	undefined	0	Overload conditions can cause unexpected outputs

**Package Dimensions in mm**

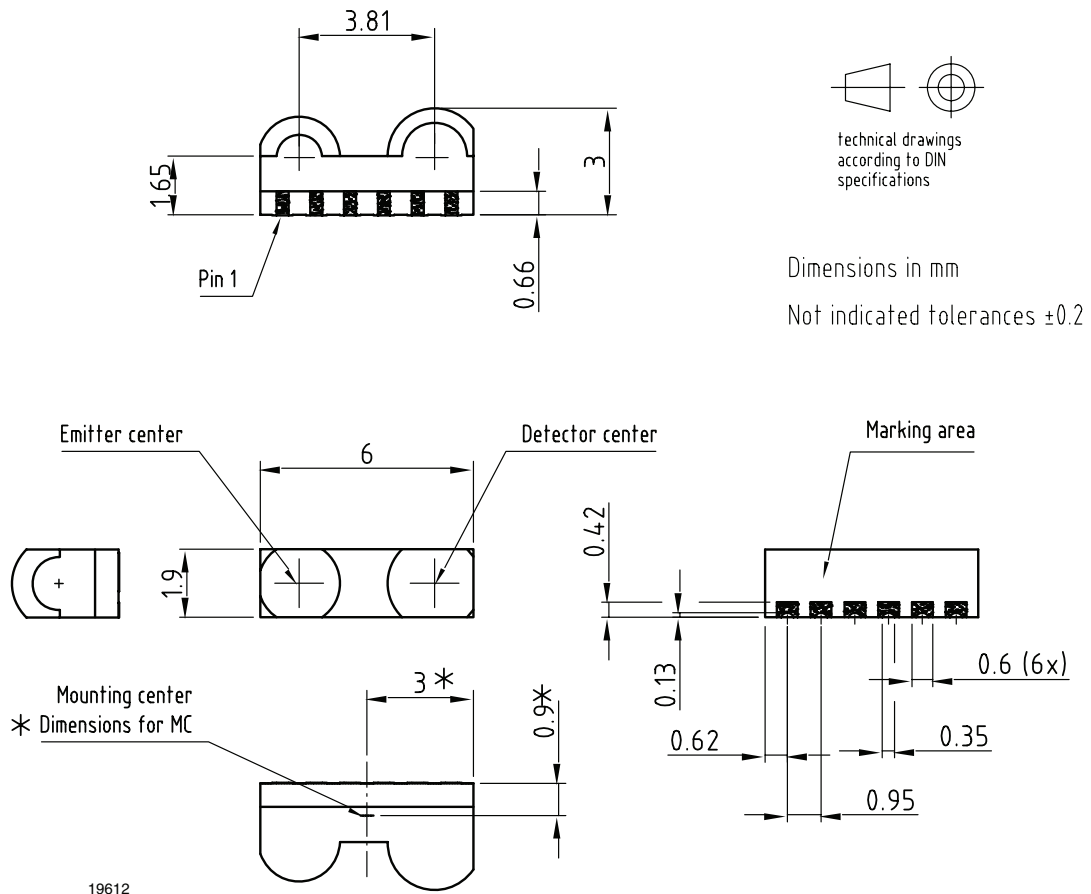

Figure 4. Package drawing of TFBS4711, tolerance of height is + 0.1mm, - 0.2 mm, other tolerances ± 0.2 mm

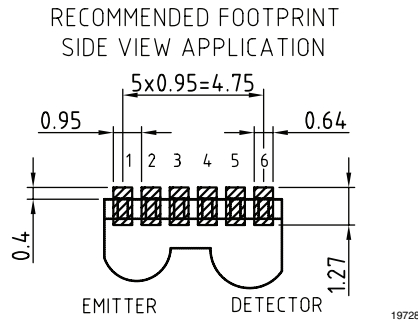
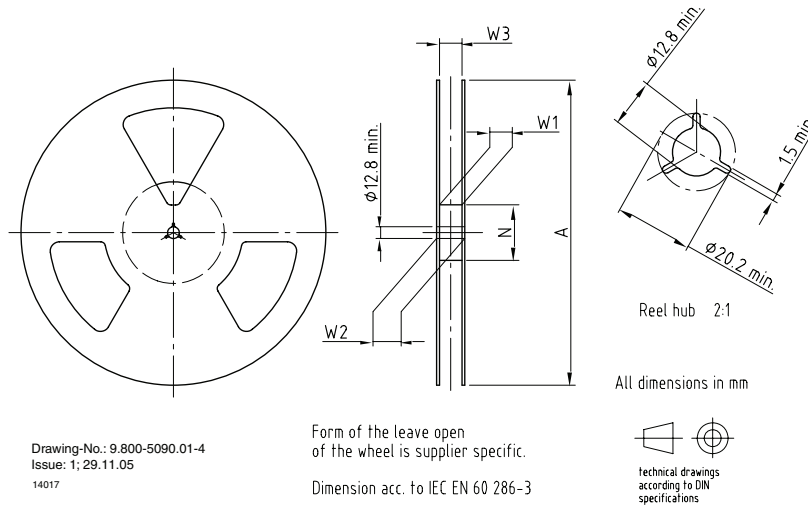

Figure 5. Recommended Solder Footprint

Reel Dimensions



Tape Width	A max.	N	W <sub>1</sub> min.	W <sub>2</sub> max.	W <sub>3</sub> min.	W <sub>3</sub> max.
mm	mm	mm	mm	mm	mm	mm
16	330	50	16.4	22.4	15.9	19.4



**Tape Dimensions in mm**

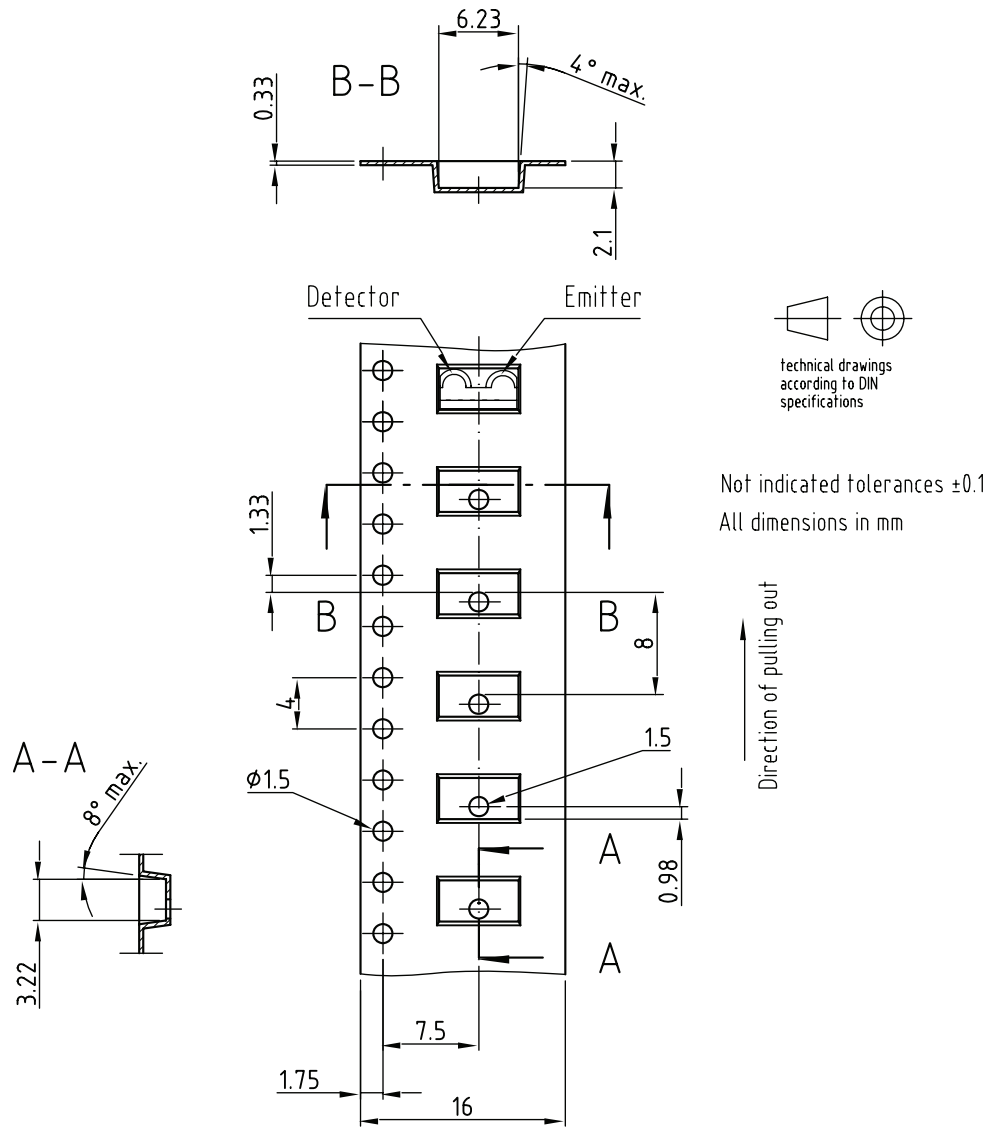

Drawing-No.: 9.700-5294.01-4  
Issue: 1; 08.12.04  
19613

Tape Dimensions in mm

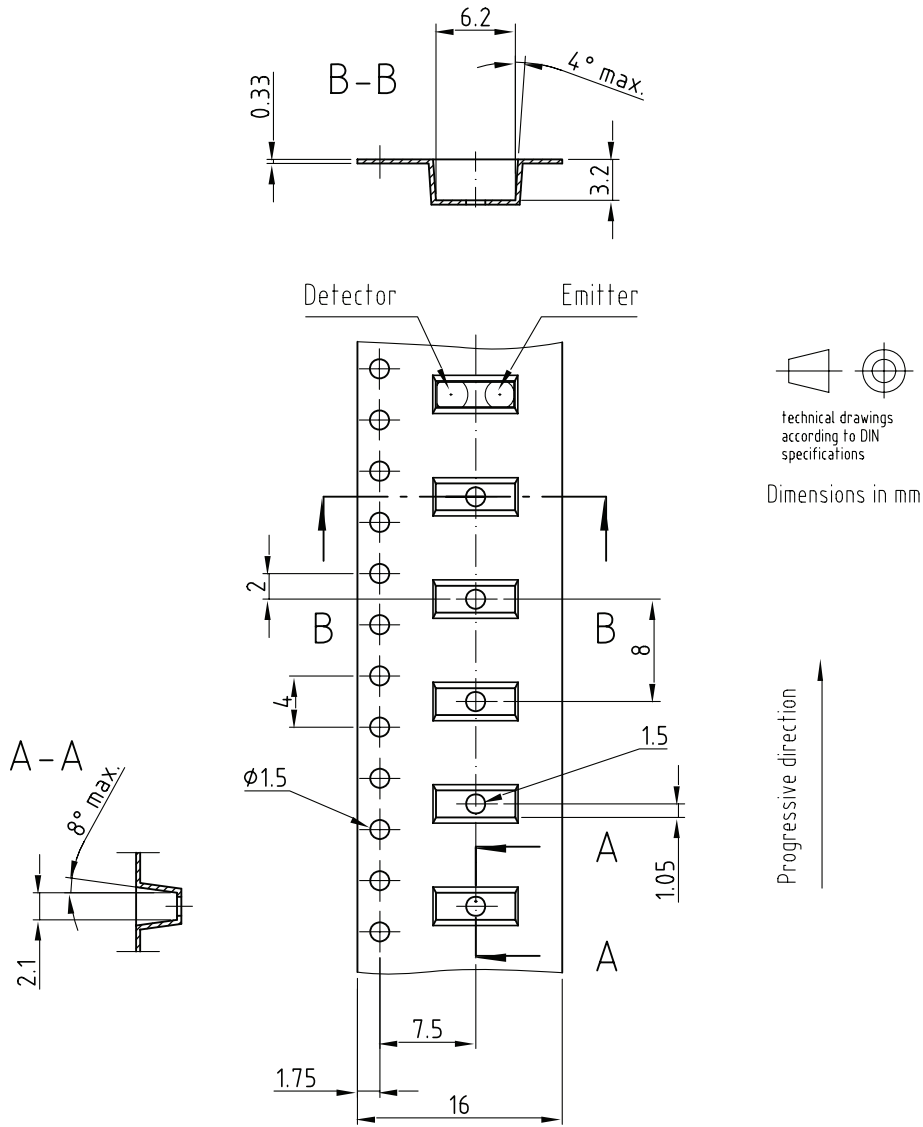

Drawing-No.: 9.700-5295.01-4  
Issue: 1; 08.12.04  
20416

## Ozone Depleting Substances Policy Statement

It is the policy of Vishay Semiconductor GmbH to

1. Meet all present and future national and international statutory requirements.
2. Regularly and continuously improve the performance of our products, processes, distribution and operating systems with respect to their impact on the health and safety of our employees and the public, as well as their impact on the environment.

It is particular concern to control or eliminate releases of those substances into the atmosphere which are known as ozone depleting substances (ODSs).

The Montreal Protocol (1987) and its London Amendments (1990) intend to severely restrict the use of ODSs and forbid their use within the next ten years. Various national and international initiatives are pressing for an earlier ban on these substances.

Vishay Semiconductor GmbH has been able to use its policy of continuous improvements to eliminate the use of ODSs listed in the following documents.

1. Annex A, B and list of transitional substances of the Montreal Protocol and the London Amendments respectively
2. Class I and II ozone depleting substances in the Clean Air Act Amendments of 1990 by the Environmental Protection Agency (EPA) in the USA
3. Council Decision 88/540/EEC and 91/690/EEC Annex A, B and C (transitional substances) respectively.

Vishay Semiconductor GmbH can certify that our semiconductors are not manufactured with ozone depleting substances and do not contain such substances.

We reserve the right to make changes to improve technical design  
and may do so without further notice.

Parameters can vary in different applications. All operating parameters must be validated for each customer application by the customer. Should the buyer use Vishay Semiconductors products for any unintended or unauthorized application, the buyer shall indemnify Vishay Semiconductors against all claims, costs, damages, and expenses, arising out of, directly or indirectly, any claim of personal damage, injury or death associated with such unintended or unauthorized use.

Vishay Semiconductor GmbH, P.O.B. 3535, D-74025 Heilbronn, Germany



## Notice

Specifications of the products displayed herein are subject to change without notice. Vishay Intertechnology, Inc., or anyone on its behalf, assumes no responsibility or liability for any errors or inaccuracies.

Information contained herein is intended to provide a product description only. No license, express or implied, by estoppel or otherwise, to any intellectual property rights is granted by this document. Except as provided in Vishay's terms and conditions of sale for such products, Vishay assumes no liability whatsoever, and disclaims any express or implied warranty, relating to sale and/or use of Vishay products including liability or warranties relating to fitness for a particular purpose, merchantability, or infringement of any patent, copyright, or other intellectual property right.

The products shown herein are not designed for use in medical, life-saving, or life-sustaining applications. Customers using or selling these products for use in such applications do so at their own risk and agree to fully indemnify Vishay for any damages resulting from such improper use or sale.