

Low Current 13 mm Seven Segment Display

Description

The TDSL51.0 series are 13 mm character seven segment low current LED displays in a very compact package.

The displays are designed for a viewing distance up to 7 meters and available in high efficiency red. The grey package surface and the evenly lighted untinted segments provide an optimum on-off contrast.

All displays are categorized in luminous intensity groups. That allows users to assemble displays with uniform appearance.

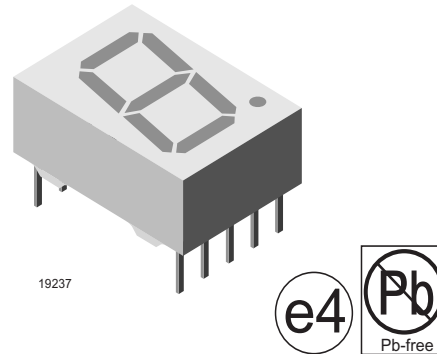

Typical applications include instruments, panel meters, point-of-sale terminals and household equipment.

Applications

Panel meters
 Test- and measure- equipment
 Point-of-sale terminals
 Control units

Features

- Low power consumption
- Suitable for DC and multiplex operation
- Evenly lighted segments
- Grey package surface
- Untinted segments
- Luminous intensity categorized
- Wide viewing angle
- Lead-free device

Parts Table

| Part | Color, Luminous Intensity | Circuitry |
|----------|---------------------------|----------------|
| TDSL5150 | Red | Common anode |
| TDSL5160 | Red | Common cathode |

Absolute Maximum Ratings

$T_{amb} = 25^{\circ}\text{C}$, unless otherwise specified

TDSL5150/TDSL5160

| Parameter | Test condition | Symbol | Value | Unit |
|-----------------------------------|--|-----------|-------|------|
| Reverse voltage per segment | | V_R | 6 | V |
| DC forward current per segment | | I_F | 15 | mA |
| Peak forward current per segment | | I_{FM} | 45 | mA |
| Surge forward current per segment | $t_p \leq 10 \mu\text{s}$ (non repetitive) | I_{FSM} | 100 | mA |
| Power dissipation | $T_{amb} \leq 45^{\circ}\text{C}$ | P_V | 320 | mW |

| Parameter | Test condition | Symbol | Value | Unit |
|---|---|------------|-------------|------|
| Junction temperature | | T_j | 100 | °C |
| Operating temperature range | | T_{amb} | -40 to + 85 | °C |
| Storage temperature range | | T_{stg} | -40 to + 85 | °C |
| Soldering temperature | $t \leq 3$ sec, 2mm below seating plane | T_{sd} | 260 | °C |
| Thermal resistance LED junction/ambient | | R_{thJA} | 180 | K/W |

Optical and Electrical Characteristics

$T_{amb} = 25$ °C, unless otherwise specified

Red

TDSL5150/TDSL5160

| Parameter | Test condition | Symbol | Min | Typ. | Max | Unit |
|--|-------------------------------|-------------|-----|----------|-----|----------|
| Luminous intensity per segment (digit average) ¹⁾ | $I_F = 2$ mA | I_V | 280 | 400 | | μ cd |
| | $I_F = 5$ mA | I_V | | 1600 | | μ cd |
| | $I_F = 20$ mA, $t_p/T = 0.25$ | I_V | | 2000 | | μ cd |
| Dominant wavelength | $I_F = 2$ mA | λ_d | 612 | | 625 | nm |
| Peak wavelength | $I_F = 2$ mA | λ_p | | 635 | | nm |
| Angle of half intensity | $I_F = 2$ mA | ϕ | | ± 50 | | deg |
| Forward voltage per segment | $I_F = 2$ mA | V_F | | 1.8 | 2.4 | V |
| | $I_F = 20$ mA | V_F | | 2.7 | 3 | V |
| Reverse voltage per segment | $I_R = 10$ μ A | V_R | 6 | 20 | | V |
| Junction capacitance | $V_R = 0$, $f = 1$ MHz | C_j | | 30 | | pF |

¹⁾ I_{Vmin} and I_V groups are mean

Typical Characteristics ($T_{amb} = 25$ °C unless otherwise specified)

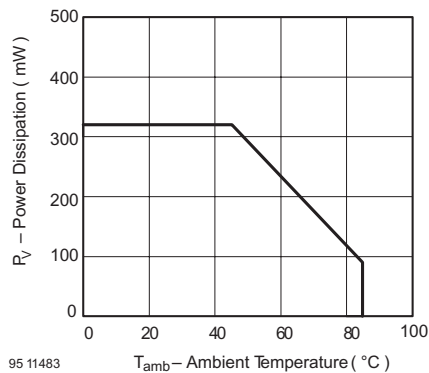

Figure 1. Power Dissipation vs. Ambient Temperature

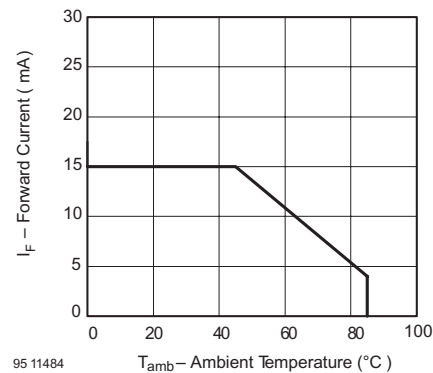
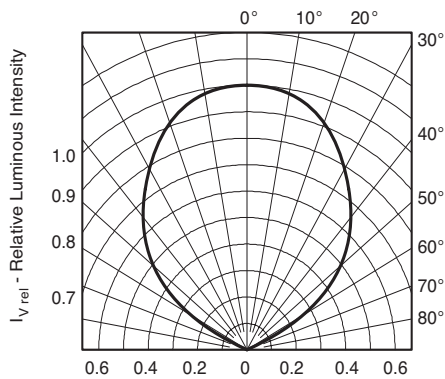
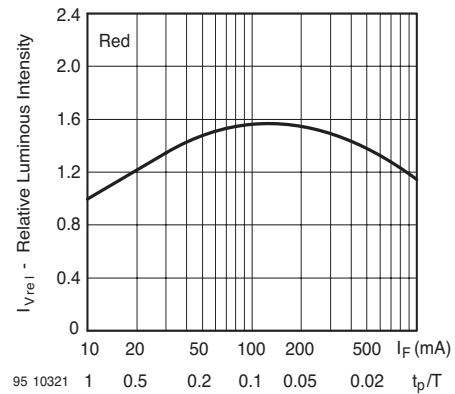

Figure 2. Forward Current vs. Ambient Temperature for AlInGaP



95 10082

Figure 3. Rel. Luminous Intensity vs. Angular Displacement



95 10321

Figure 6. Rel. Lumin. Intensity vs. Forw. Current/Duty Cycle

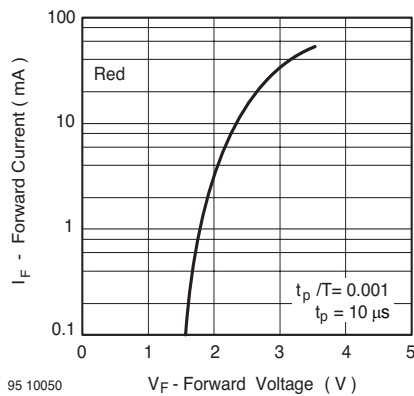

95 10050

Figure 4. Forward Current vs. Forward Voltage

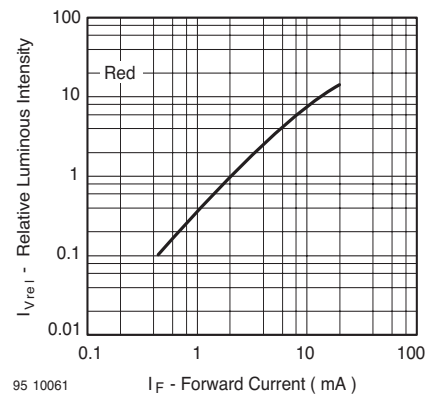

95 10061

Figure 7. Relative Luminous Intensity vs. Forward Current

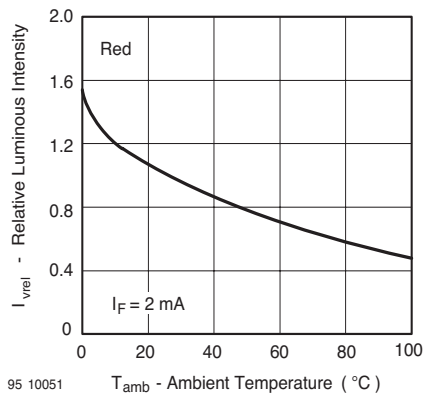

95 10051

Figure 5. Rel. Luminous Intensity vs. Ambient Temperature

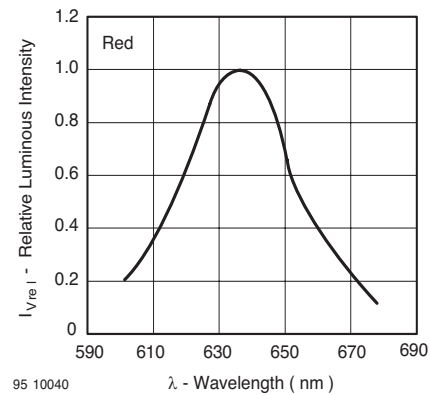

95 10040

Figure 8. Relative Intensity vs. Wavelength

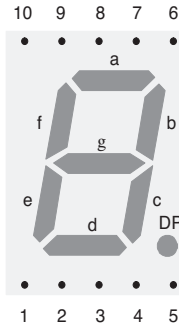

- 1 e
- 2 d
- 3 A (C)
- 4 c
- 5 DP
- 6 b
- 7 a
- 8 A (C)
- 9 f
- 10 g

95 10896

Package Dimensions in mm

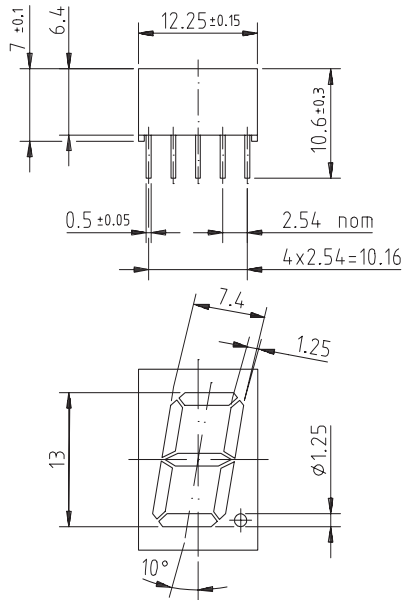

Technical drawings according to DIN specifications

95 11344

Ozone Depleting Substances Policy Statement

It is the policy of **Vishay Semiconductor GmbH** to

1. Meet all present and future national and international statutory requirements.
2. Regularly and continuously improve the performance of our products, processes, distribution and operating systems with respect to their impact on the health and safety of our employees and the public, as well as their impact on the environment.

It is particular concern to control or eliminate releases of those substances into the atmosphere which are known as ozone depleting substances (ODSs).

The Montreal Protocol (1987) and its London Amendments (1990) intend to severely restrict the use of ODSs and forbid their use within the next ten years. Various national and international initiatives are pressing for an earlier ban on these substances.

Vishay Semiconductor GmbH has been able to use its policy of continuous improvements to eliminate the use of ODSs listed in the following documents.

1. Annex A, B and list of transitional substances of the Montreal Protocol and the London Amendments respectively
2. Class I and II ozone depleting substances in the Clean Air Act Amendments of 1990 by the Environmental Protection Agency (EPA) in the USA
3. Council Decision 88/540/EEC and 91/690/EEC Annex A, B and C (transitional substances) respectively.

Vishay Semiconductor GmbH can certify that our semiconductors are not manufactured with ozone depleting substances and do not contain such substances.

**We reserve the right to make changes to improve technical design
and may do so without further notice.**

Parameters can vary in different applications. All operating parameters must be validated for each customer application by the customer. Should the buyer use Vishay Semiconductors products for any unintended or unauthorized application, the buyer shall indemnify Vishay Semiconductors against all claims, costs, damages, and expenses, arising out of, directly or indirectly, any claim of personal damage, injury or death associated with such unintended or unauthorized use.

Vishay Semiconductor GmbH, P.O.B. 3535, D-74025 Heilbronn, Germany
Telephone: 49 (0)7131 67 2831, Fax number: 49 (0)7131 67 2423



Disclaimer

All product specifications and data are subject to change without notice.

Vishay Intertechnology, Inc., its affiliates, agents, and employees, and all persons acting on its or their behalf (collectively, "Vishay"), disclaim any and all liability for any errors, inaccuracies or incompleteness contained herein or in any other disclosure relating to any product.

Vishay disclaims any and all liability arising out of the use or application of any product described herein or of any information provided herein to the maximum extent permitted by law. The product specifications do not expand or otherwise modify Vishay's terms and conditions of purchase, including but not limited to the warranty expressed therein, which apply to these products.

No license, express or implied, by estoppel or otherwise, to any intellectual property rights is granted by this document or by any conduct of Vishay.

The products shown herein are not designed for use in medical, life-saving, or life-sustaining applications unless otherwise expressly indicated. Customers using or selling Vishay products not expressly indicated for use in such applications do so entirely at their own risk and agree to fully indemnify Vishay for any damages arising or resulting from such use or sale. Please contact authorized Vishay personnel to obtain written terms and conditions regarding products designed for such applications.

Product names and markings noted herein may be trademarks of their respective owners.