

SUCW1R5

SUC W 1R5 12 12 B P - □

① ② ③ ④ ⑤ ⑥ ⑦ ⑧



RoHS

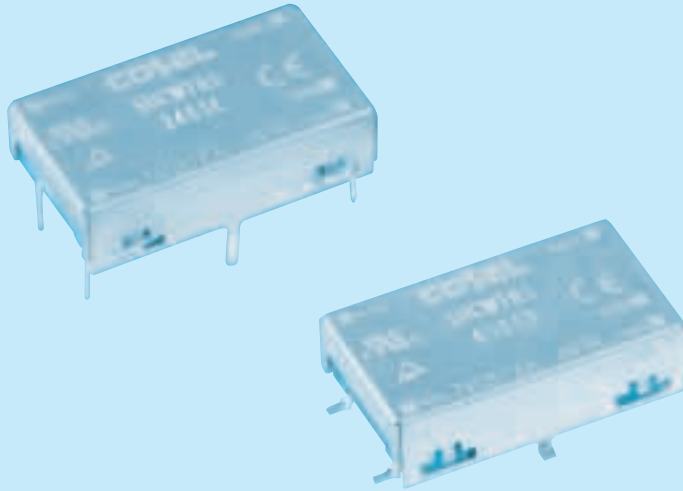

- ① Series name
 - ② Dual output
 - ③ Output wattage
 - ④ Input voltage
 - ⑤ Output voltage
 - ⑥ Mounting type
B : SMD
C : DIP
 - ⑦ Packing form
Blank: Plastic cover
P : Tray (SMD type)
 - ⑧ Optional
C : with coating (only DIP type)*
- * Safety standards are pending

MODEL	SUCW1R50512	SUCW1R50515	SUCW1R51212	SUCW1R51215	SUCW1R52412	SUCW1R52415	SUCW1R54812	SUCW1R54815
MAX OUTPUT WATTAGE[W]	1.56	1.5	1.56	1.5	1.56	1.5	1.56	1.5
DC OUTPUT	VOLTAGE[V] *1	±12 or +24	±15 or +30	±12 or +24	±15 or +30	±12 or +24	±15 or +30	±12 or +24
	CURRENT[A]	0.065	0.05	0.065	0.05	0.065	0.05	0.065

SPECIFICATIONS

	MODEL	SUCW1R50512	SUCW1R50515	SUCW1R51212	SUCW1R51215	SUCW1R52412	SUCW1R52415	SUCW1R54812	SUCW1R54815	
INPUT	VOLTAGE[V]	DC4.5 - 9		DC9 - 18		DC18 - 36		DC36 - 76		
	CURRENT[A]	*2 0.446typ	0.429typ	0.178typ	0.171typ	0.089typ	0.086typ	0.045typ	0.043typ	
	EFFICIENCY[%]	*2 70typ	70typ	73typ	73typ	73typ	73typ	73typ	73typ	
OUTPUT	VOLTAGE[V]	±12(+24)	±15(+30)	±12(+24)	±15(+30)	±12(+24)	±15(+30)	±12(+24)	±15(+30)	
	CURRENT[A]	0.065	0.05	0.065	0.05	0.065	0.05	0.065	0.05	
	LINE REGULATION[mV]	60max	75max	60max	75max	60max	75max	60max	75max	
	LOAD REGULATION[mV]	600max	750max	600max	750max	600max	750max	600max	750max	
	RIPPLE[mVp-p]	-20 to +55°C *3	120max	120max	120max	120max	120max	120max	120max	120max
		-40 to -20°C *3	150max	150max	150max	150max	150max	150max	150max	150max
	RIPPLE NOISE[mVp-p]	-20 to +55°C *3	150max	150max	150max	150max	150max	150max	150max	150max
		-40 to -20°C *3	200max	200max	200max	200max	200max	200max	200max	200max
	TEMPERATURE REGULATION[mV]	-20 to +55°C	150max	180max	150max	180max	150max	180max	150max	180max
		-40 to +55°C	240max	290max	240max	290max	240max	290max	240max	290max
DRIFT[mV]	*4 50max	60max	50max	60max	50max	60max	50max	60max		
START-UP TIME[ms]	20max (Minimum input, I _o =100%)									
OUTPUT VOLTAGE ADJUSTMENT RANGE	Fixed (TRM pin open) ±5% adjustable by external VR									
OUTPUT VOLTAGE SETTING[V] (±5%)	11.40 - 12.60	14.25 - 15.75	11.40 - 12.60	14.25 - 15.75	11.40 - 12.60	14.25 - 15.75	11.40 - 12.60	14.25 - 15.75		
OVERCURRENT PROTECTION	Works over 105% of rating and recovers automatically									
ISOLATION	INPUT-OUTPUT	AC500V 1minute, Cutoff current = 10mA, DC500V 50MΩ min (20±15°C)								
	INPUT-CASE	AC500V 1minute, Cutoff current = 10mA, DC500V 50MΩ min (20±15°C)								
	OUTPUT-CASE	AC500V 1minute, Cutoff current = 10mA, DC500V 50MΩ min (20±15°C)								
ENVIRONMENT	OPERATING TEMP., HUMID. AND ALTITUDE	-40 to +85°C, 20 - 95%RH (Non condensing) (Required Derating), 3,000m (10,000feet) max								
	STORAGE TEMP., HUMID. AND ALTITUDE	-40 to +100°C, 20 - 95%RH (Non condensing), 9,000m (30,000feet) max								
	VIBRATION	10 - 55Hz, 98.0m/s ² (10G), 3minutes period, 60minutes each along X, Y and Z axis								
	IMPACT	490.3m/s ² (50G), 11ms, once each along X, Y and Z axis								
SAFETY	AGENCY APPROVALS	UL60950-1, C-UL, EN60950-1								
OTHERS	CASE SIZE/WEIGHT	22.4 × 7.0 × 13.2mm (W × H × D) / 3g max								
	COOLING METHOD	Convection/Forced air								

*1 Output pins can be connected in series to make a 24V/30V output.
 *2 Rated input 5V, 12V, 24V or 48V DC I_o=100%
 *3 Ripple and Ripple Noise is measured by using measuring board with capacitor with in 25mm from output pin terminals.
 *4 Drift is the change in DC output for an eight hour period after a half-hour warm-up at 25°C.
 * Parallel operation with other model is not possible.

External view

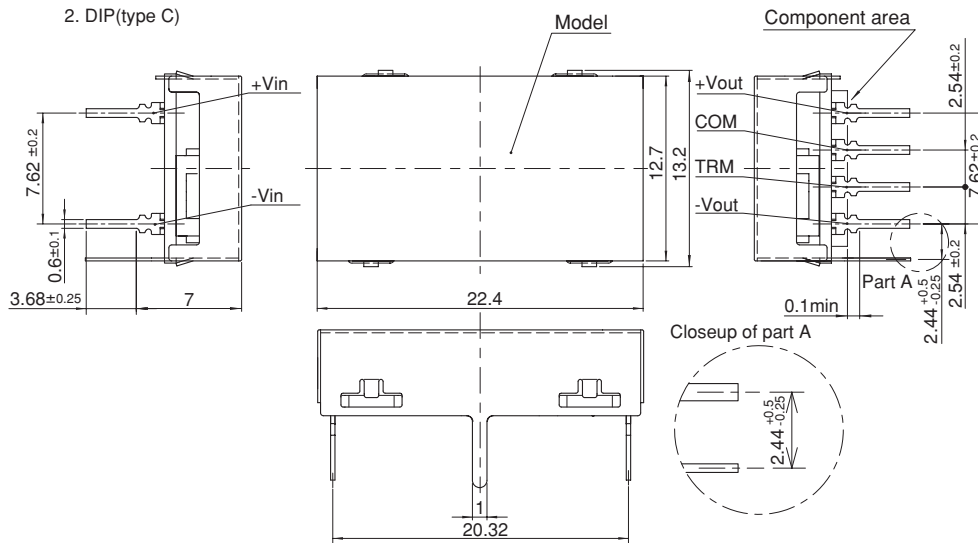
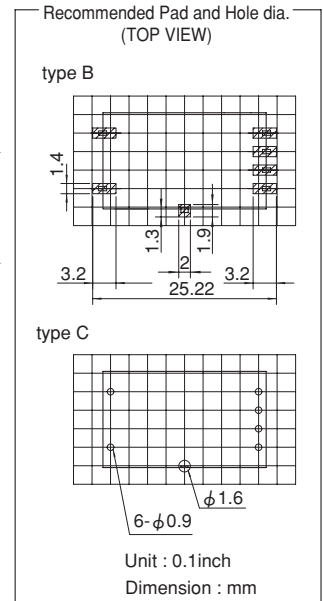
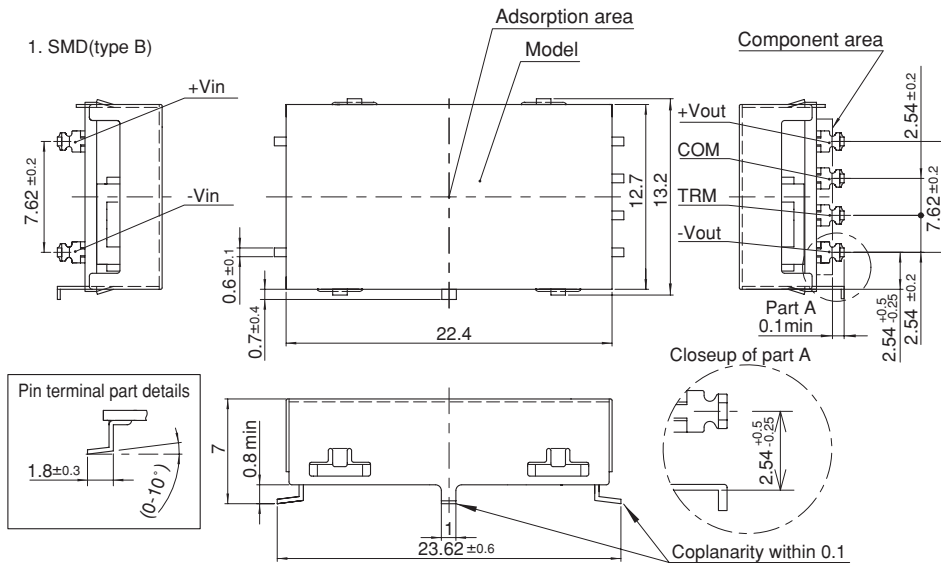

- ※ Tolerance ±0.5
- ※ Dimensions in mm
- ※ Pin terminal thickness : 0.3±0.1
- ※ Pin terminal material : Copper alloy
- ※ Plating treatment of terminal : Lead free plating
- ※ Case thickness : 0.2±0.05
- ※ Case material : Brass
- ※ Plating treatment of case : Nickel plating
- ※ Please keep enough creepage distance with the pattern on PCB and other components.
- ※ Mass 3g less

SUCW3

SUC W 3 12 12 B P - □

① ② ③ ④ ⑤ ⑥ ⑦ ⑧



RoHS

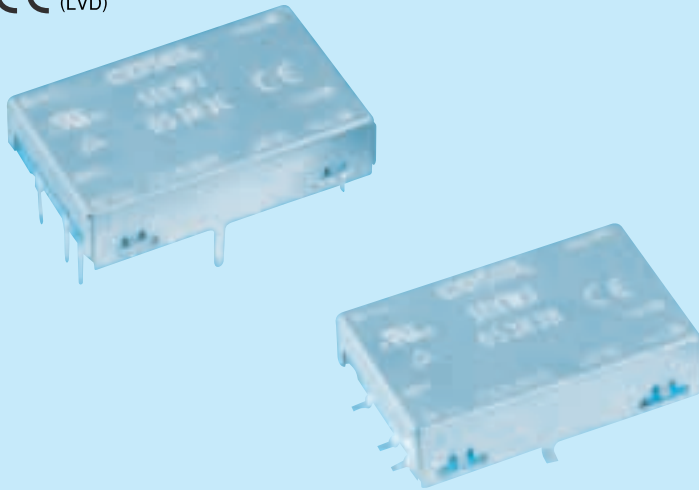

- ① Series name
 - ② Dual output
 - ③ Output wattage
 - ④ Input voltage
 - ⑤ Output voltage
 - ⑥ Mounting type
B : SMD
C : DIP
 - ⑦ Packing form
Blank: Plastic cover
P : Tray (SMD type)
 - ⑧ Optional
G : Capacitor between Input and Output is removed.
C : with coating (only DIP type)*
- * Safety standards are pending

MODEL	SUCW30512	SUCW30515	SUCW31212	SUCW31215	SUCW32412	SUCW32415	SUCW34812	SUCW34815	
MAX OUTPUT WATTAGE[W]	3.12	3	3.12	3	3.12	3	3.12	3	
DC OUTPUT	VOLTAGE[V] *1	±12 or +24	±15 or +30	±12 or +24	±15 or +30	±12 or +24	±15 or +30	±12 or +24	±15 or +30
	CURRENT[A]	0.13	0.1	0.13	0.1	0.13	0.1	0.13	0.1

SPECIFICATIONS

	MODEL	SUCW30512	SUCW30515	SUCW31212	SUCW31215	SUCW32412	SUCW32415	SUCW34812	SUCW34815	
INPUT	VOLTAGE[V]	DC4.5 - 9		DC9 - 18		DC18 - 36		DC36 - 76		
	CURRENT[A] *2	0.844typ	0.811typ	0.343typ	0.329typ	0.172typ	0.165typ	0.086typ	0.083typ	
	EFFICIENCY[%] *2	74typ	74typ	76typ	76typ	76typ	76typ	76typ	76typ	
OUTPUT	VOLTAGE[V]	±12(+24)	±15(+30)	±12(+24)	±15(+30)	±12(+24)	±15(+30)	±12(+24)	±15(+30)	
	CURRENT[A]	0.13	0.1	0.13	0.1	0.13	0.1	0.13	0.1	
	LINE REGULATION[mV]	60max	75max	60max	75max	60max	75max	60max	75max	
	LOAD REGULATION[mV]	600max	750max	600max	750max	600max	750max	600max	750max	
	RIPPLE[mVp-p]	-20 to +55°C *3	120max	120max	120max	120max	120max	120max	120max	120max
		-40 to -20°C *3	150max	150max	150max	150max	150max	150max	150max	150max
	RIPPLE NOISE[mVp-p]	-20 to +55°C *3	150max	150max	150max	150max	150max	150max	150max	150max
		-40 to -20°C *3	200max	200max	200max	200max	200max	200max	200max	200max
	TEMPERATURE REGULATION[mV]	-20 to +55°C	150max	180max	150max	180max	150max	180max	150max	180max
		-40 to +55°C	240max	290max	240max	290max	240max	290max	240max	290max
DRIFT[mV] *4	50max	60max	50max	60max	50max	60max	50max	60max		
START-UP TIME[ms]	20max (Minimum input, I _o =100%)									
OUTPUT VOLTAGE ADJUSTMENT RANGE	Fixed (TRM pin open) ±5% adjustable by external VR									
OUTPUT VOLTAGE SETTING[V] (±5%)	11.40 - 12.60	14.25 - 15.75	11.40 - 12.60	14.25 - 15.75	11.40 - 12.60	14.25 - 15.75	11.40 - 12.60	14.25 - 15.75		
PROTECTION CIRCUIT AND OTHERS	OVERCURRENT PROTECTION	Works over 105% of rating and recovers automatically								
	REMOTE ON/OFF	Provided (Negative logic L : ON, H : OFF)								
ISOLATION	INPUT-OUTPUT	AC500V 1minute, Cutoff current = 10mA, DC500V 50MΩ min (20±15°C)								
	INPUT-CASE	AC500V 1minute, Cutoff current = 10mA, DC500V 50MΩ min (20±15°C)								
	OUTPUT-CASE	AC500V 1minute, Cutoff current = 10mA, DC500V 50MΩ min (20±15°C)								
ENVIRONMENT	OPERATING TEMP., HUMID. AND ALTITUDE	-40 to +85°C, 20 - 95%RH (Non condensing) (Required Derating), 3,000m (10,000feet) max								
	STORAGE TEMP., HUMID. AND ALTITUDE	-40 to +100°C, 20 - 95%RH (Non condensing), 9,000m (30,000feet) max								
	VIBRATION	10 - 55Hz, 98.0m/s ² (10G), 3minutes period, 60minutes each along X, Y and Z axis								
	IMPACT	490.3m/s ² (50G), 11ms, once each along X, Y and Z axis								
SAFETY	AGENCY APPROVALS	UL60950-1, C-UL, EN60950-1								
OTHERS	CASE SIZE/WEIGHT	25 × 7.0 × 16.1mm (W × H × D) / 5g max								
	COOLING METHOD	Convection/Forced air								

*1 Output pins can be connected in series to make a 24V/30V output.
 *2 Rated input 5V, 12V, 24V or 48V DC I_o=100%
 *3 Ripple and Ripple Noise is measured by using measuring board with capacitor with in 25mm from output pin terminals.
 *4 Drift is the change in DC output for an eight hour period after a half-hour warm-up at 25°C.
 * Parallel operation with other model is not possible.

External view

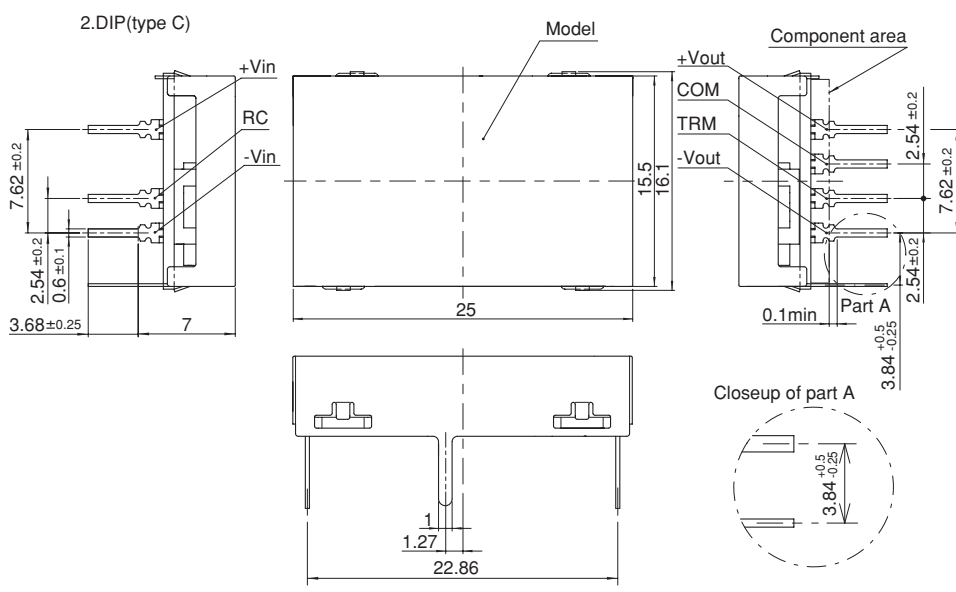
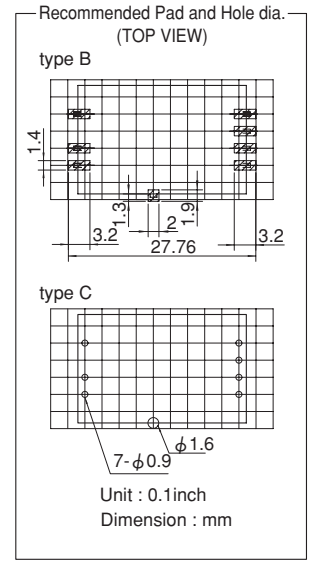
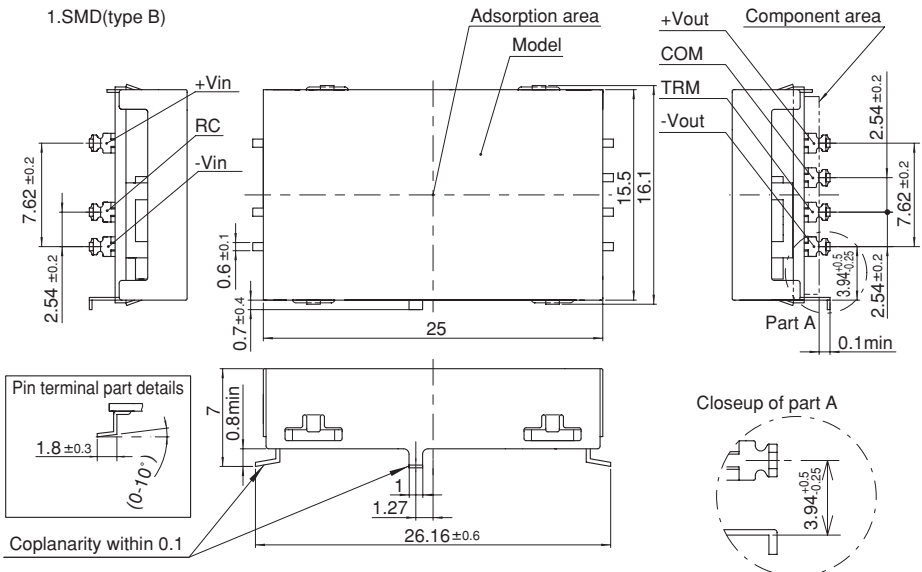

- ※ Tolerance ±0.5
- ※ Dimensions in mm
- ※ Pin terminal thickness : 0.3±0.1
- ※ Pin terminal material : Copper alloy
- ※ Plating treatment of terminal : Lead free plating
- ※ Case thickness : 0.2±0.05
- ※ Case material : Brass
- ※ Plating treatment of case : Nickel plating
- ※ Please keep enough creepage distance with the pattern on PCB and other components.
- ※ Mass 5g less

SUCUSUT

SUCW6

SUC W 6 12 12 B P - □

① ② ③ ④ ⑤ ⑥ ⑦ ⑧



- ① Series name
 - ② Dual output
 - ③ Output wattage
 - ④ Input voltage
 - ⑤ Output voltage
 - ⑥ Mounting type
B : SMD
C : DIP
 - ⑦ Packing form
Blank: Plastic cover
P : Tray (SMD type)
 - ⑧ Optional
G : Capacitor between Input and Output is removed.
C : with coating (only DIP type)*
- * Safety standards are pending

MODEL	SUCW60512	SUCW60515	SUCW61212	SUCW61215	SUCW62412	SUCW62415	SUCW64812	SUCW64815	
MAX OUTPUT WATTAGE[W]	6	6	6	6	6	6	6	6	
DC OUTPUT	VOLTAGE[V] *1	±12 or +24	±15 or +30	±12 or +24	±15 or +30	±12 or +24	±15 or +30	±12 or +24	±15 or +30
	CURRENT[A]	0.25	0.2	0.25	0.2	0.25	0.2	0.25	0.2

SPECIFICATIONS

	MODEL	SUCW60512	SUCW60515	SUCW61212	SUCW61215	SUCW62412	SUCW62415	SUCW64812	SUCW64815	
INPUT	VOLTAGE[V]	DC4.5 - 9		DC9 - 18		DC18 - 36		DC36 - 76		
	CURRENT[A] *2	1.538typ	1.538typ	0.588typ	0.588typ	0.291typ	0.291typ	0.145typ	0.145typ	
	EFFICIENCY[%] *2	78typ	78typ	85typ	85typ	86typ	86typ	86typ	86typ	
OUTPUT	VOLTAGE[V]	±12(+24)	±15(+30)	±12(+24)	±15(+30)	±12(+24)	±15(+30)	±12(+24)	±15(+30)	
	CURRENT[A]	0.25	0.2	0.25	0.2	0.25	0.2	0.25	0.2	
	LINE REGULATION[mV]	60max	75max	60max	75max	60max	75max	60max	75max	
	LOAD REGULATION[mV]	600max	750max	600max	750max	600max	750max	600max	750max	
	RIPPLE[mVp-p]	-20 to +55°C *3	120max	120max	120max	120max	120max	120max	120max	120max
		-40 to -20°C *3	150max	150max	150max	150max	150max	150max	150max	150max
	RIPPLE NOISE[mVp-p]	-20 to +55°C *3	150max	150max	150max	150max	150max	150max	150max	150max
		-40 to -20°C *3	200max	200max	200max	200max	200max	200max	200max	200max
	TEMPERATURE REGULATION[mV]	-20 to +55°C	150max	180max	150max	180max	150max	180max	150max	180max
		-40 to +55°C	240max	290max	240max	290max	240max	290max	240max	290max
DRIFT[mV] *4	50max	60max	50max	60max	50max	60max	50max	60max		
START-UP TIME[ms]	20max (Minimum input, I _o =100%)									
OUTPUT VOLTAGE ADJUSTMENT RANGE	Fixed (TRM pin open) ±5% adjustable by external VR									
OUTPUT VOLTAGE SETTING[V] (±5%)	11.40 - 12.60	14.25 - 15.75	11.40 - 12.60	14.25 - 15.75	11.40 - 12.60	14.25 - 15.75	11.40 - 12.60	14.25 - 15.75		
PROTECTION CIRCUIT AND OTHERS	OVERCURRENT PROTECTION	Works over 105% of rating and recovers automatically								
	REMOTE ON/OFF	Provided (Negative logic L : ON, H : OFF)								
ISOLATION	INPUT-OUTPUT	AC500V 1minute, Cutoff current = 10mA, DC500V 50MΩ min (20±15°C)								
	INPUT-CASE	AC500V 1minute, Cutoff current = 10mA, DC500V 50MΩ min (20±15°C)								
	OUTPUT-CASE	AC500V 1minute, Cutoff current = 10mA, DC500V 50MΩ min (20±15°C)								
ENVIRONMENT	OPERATING TEMP., HUMID. AND ALTITUDE	-40 to +85°C, 20 - 95%RH (Non condensing) (Required Derating), 3,000m (10,000feet) max								
	STORAGE TEMP., HUMID. AND ALTITUDE	-40 to +100°C, 20 - 95%RH (Non condensing), 9,000m (30,000feet) max								
	VIBRATION	10 - 55Hz, 98.0m/s ² (10G), 3minutes period, 60minutes each along X, Y and Z axis								
	IMPACT	490.3m/s ² (50G), 11ms, once each along X, Y and Z axis								
SAFETY	AGENCY APPROVALS	UL60950-1, C-UL, EN60950-1								
OTHERS	CASE SIZE/WEIGHT	32.6×7.0×19.1mm (W×H×D) / 7g max								
	COOLING METHOD	Convection/Forced air								

*1 Output pins can be connected in series to make a 24V/30V output.
 *2 Rated input 5V, 12V, 24V or 48V DC I_o=100%
 *3 Ripple and Ripple Noise is measured by using measuring board with capacitor with in 25mm from output pin terminals.
 *4 Drift is the change in DC output for an eight hour period after a half-hour warm-up at 25°C.
 * Parallel operation with other model is not possible.

External view

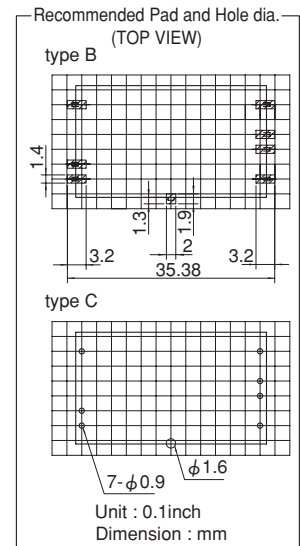
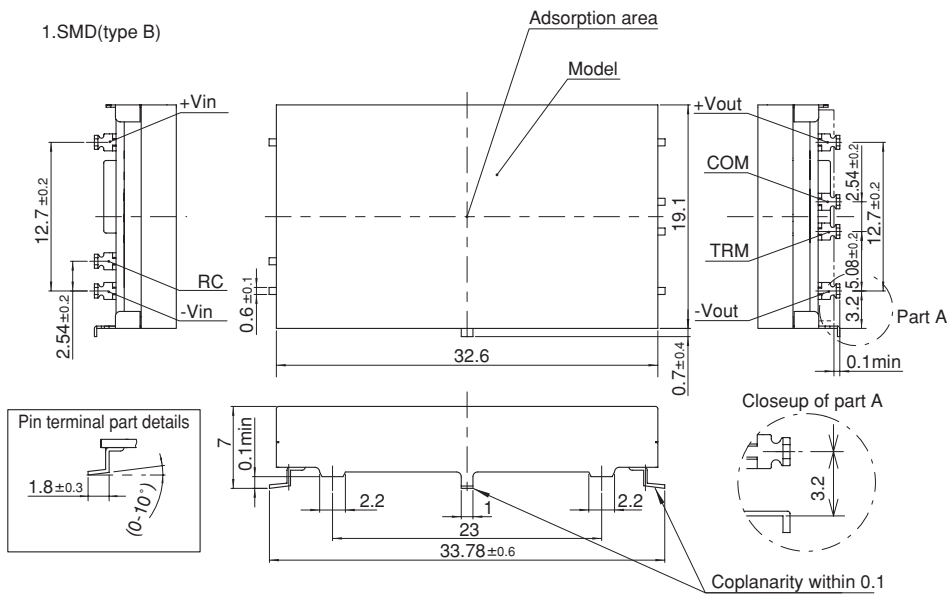

- ※ Tolerance ±0.5
- ※ Dimensions in mm
- ※ Pin terminal thickness : 0.3±0.1
- ※ Pin terminal material : Copper alloy
- ※ Plating treatment of terminal : Lead free plating
- ※ Case thickness : 0.2±0.05
- ※ Case material : Brass
- ※ Plating treatment of case : Nickel plating
- ※ Please keep enough creepage distance with the pattern on PCB and other components.
- ※ Mass 7g less

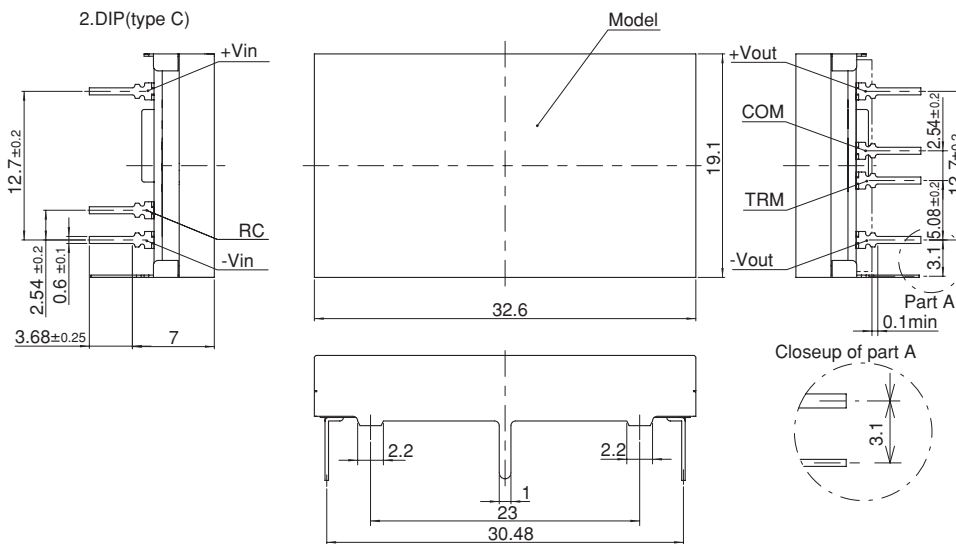

SUCW10

SUC W 10 12 12 B P -□

① ② ③ ④ ⑤ ⑥ ⑦ ⑧

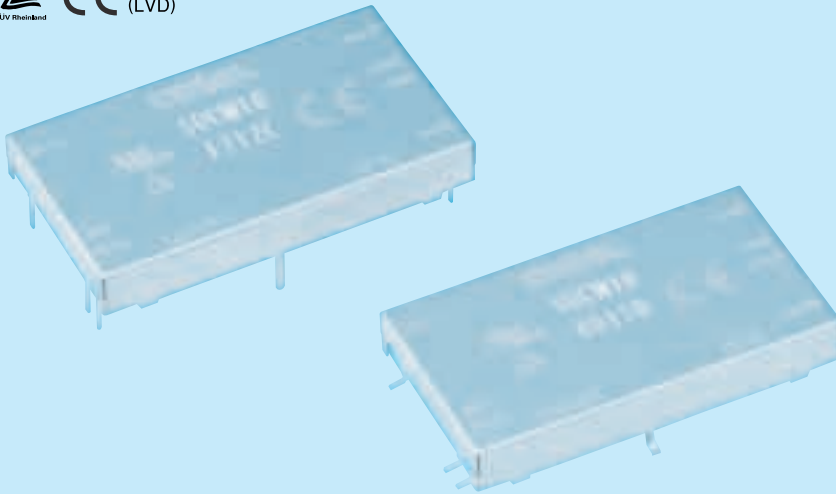

- ① Series name
 - ② Dual output
 - ③ Output wattage
 - ④ Input voltage
 - ⑤ Output voltage
 - ⑥ Mounting type
B : SMD
C : DIP
 - ⑦ Packing form
Blank: Plastic cover
P : Tray (SMD type)
 - ⑧ Optional
G : Capacitor between Input and Output is removed.
C : with coating (only DIP type)*
- * Safety standards are pending

MODEL	SUCW100512	SUCW100515	SUCW101212	SUCW101215	SUCW102412	SUCW102415	SUCW104812	SUCW104815
MAX OUTPUT WATTAGE[W]	10.8	10.5	10.8	10.5	10.8	10.5	10.8	10.5
DC OUTPUT	VOLTAGE[V] *1	±12 or +24	±15 or +30	±12 or +24	±15 or +30	±12 or +24	±15 or +30	±12 or +24
	CURRENT[A]	0.45	0.35	0.45	0.35	0.45	0.35	0.45

SPECIFICATIONS

	MODEL	SUCW100512	SUCW100515	SUCW101212	SUCW101215	SUCW102412	SUCW102415	SUCW104812	SUCW104815	
INPUT	VOLTAGE[V]	DC4.5 - 9		DC9 - 18		DC18 - 36		DC36 - 76		
	CURRENT[A] *2	2.51typ	2.44typ	1.05typ	1.02typ	0.523typ	0.509typ	0.262typ	0.254typ	
	EFFICIENCY[%] *2	86typ	86typ	86typ	86typ	86typ	86typ	86typ	86typ	
OUTPUT	VOLTAGE[V]	±12(+24)	±15(+30)	±12(+24)	±15(+30)	±12(+24)	±15(+30)	±12(+24)	±15(+30)	
	CURRENT[A]	0.45	0.35	0.45	0.35	0.45	0.35	0.45	0.35	
	LINE REGULATION[mV]	60max	75max	60max	75max	60max	75max	60max	75max	
	LOAD REGULATION[mV]	600max	750max	600max	750max	600max	750max	600max	750max	
	RIPPLE[mVp-p]	-20 to +55°C *3	120max	120max	120max	120max	120max	120max	120max	120max
		-40 to -20°C *3	150max	150max	150max	150max	150max	150max	150max	150max
	RIPPLE NOISE[mVp-p]	-20 to +55°C *3	150max	150max	150max	150max	150max	150max	150max	150max
		-40 to -20°C *3	200max	200max	200max	200max	200max	200max	200max	200max
	TEMPERATURE REGULATION[mV]	-20 to +55°C	150max	180max	150max	180max	150max	180max	150max	180max
		-40 to +55°C	240max	290max	240max	290max	240max	290max	240max	290max
DRIFT[mV] *4	50max	60max	50max	60max	50max	60max	50max	60max		
START-UP TIME[ms]	20max (Minimum input, I _o =100%)									
OUTPUT VOLTAGE ADJUSTMENT RANGE	Fixed (TRM pin open) ±5% adjustable by external VR									
OUTPUT VOLTAGE SETTING[V] (±5%)	11.40 - 12.60	14.25 - 15.75	11.40 - 12.60	14.25 - 15.75	11.40 - 12.60	14.25 - 15.75	11.40 - 12.60	14.25 - 15.75		
PROTECTION CIRCUIT AND OTHERS	OVERCURRENT PROTECTION	Works over 105% of rating and recovers automatically								
	REMOTE ON/OFF	Provided (Negative logic L : ON, H : OFF)								
ISOLATION	INPUT-OUTPUT	AC500V 1minute, Cutoff current = 10mA, DC500V 50MΩ min (20±15°C)								
	INPUT-CASE	AC500V 1minute, Cutoff current = 10mA, DC500V 50MΩ min (20±15°C)								
	OUTPUT-CASE	AC500V 1minute, Cutoff current = 10mA, DC500V 50MΩ min (20±15°C)								
ENVIRONMENT	OPERATING TEMP., HUMID. AND ALTITUDE	-40 to +85°C, 20 - 95%RH (Non condensing) (Required Derating), 3,000m (10,000feet) max								
	STORAGE TEMP., HUMID. AND ALTITUDE	-40 to +100°C, 20 - 95%RH (Non condensing), 9,000m (30,000feet) max								
	VIBRATION	10 - 55Hz, 98.0m/s ² (10G), 3minutes period, 60minutes each along X, Y and Z axis								
	IMPACT	490.3m/s ² (50G), 11ms, once each along X, Y and Z axis								
SAFETY	AGENCY APPROVALS	UL60950-1, C-UL, EN60950-1								
OTHERS	CASE SIZE/WEIGHT	40.2×7.0×22.0mm (W×H×D) / 10g max								
	COOLING METHOD	Convection/Forced air								

*1 Output pins can be connected in series to make a 24V/30V output.
 *2 Rated input 5V, 12V, 24V or 48V DC I_o=100%
 *3 Ripple and Ripple Noise is measured by using measuring board with capacitor with in 25mm from output pin terminals.
 *4 Drift is the change in DC output for an eight hour period after a half-hour warm-up at 25°C.
 * Parallel operation with other model is not possible.

External view

1.SMD(type B)

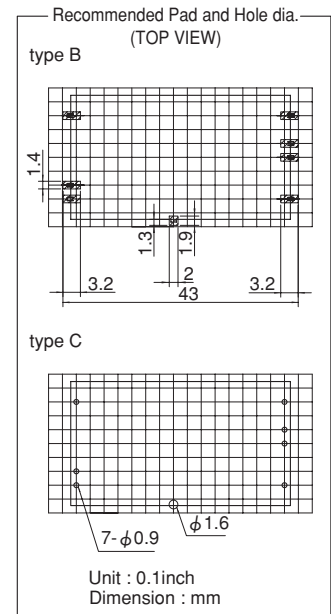
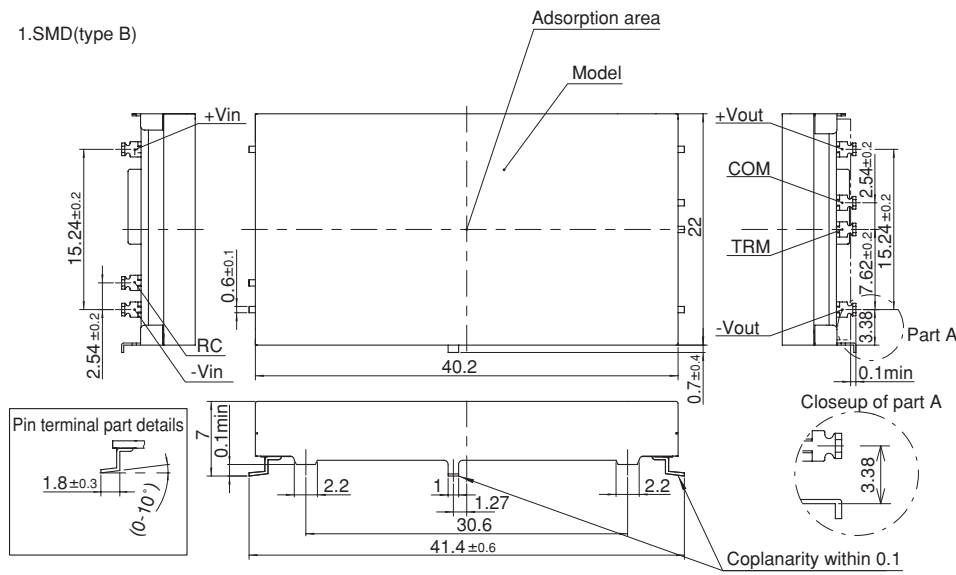

2.DIP(type C)

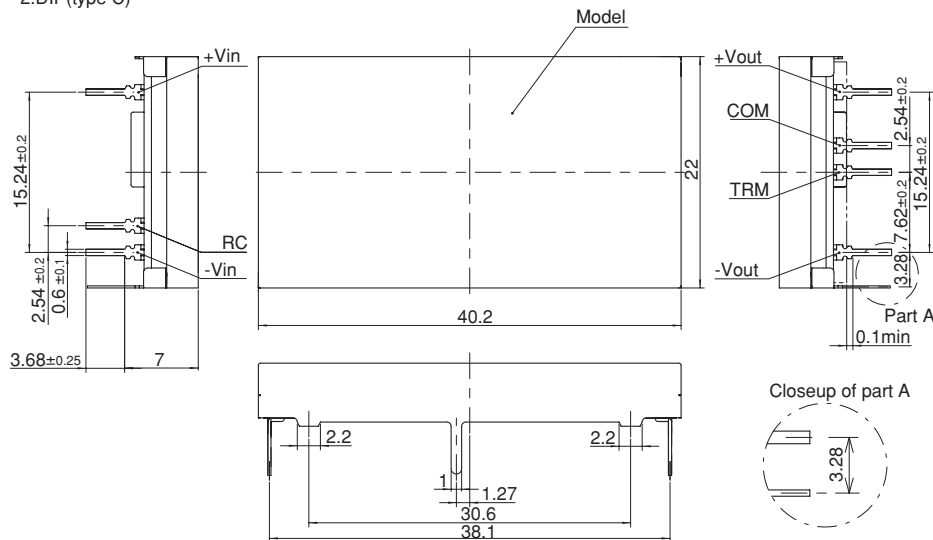

- ※ Tolerance ±0.5
- ※ Dimensions in mm
- ※ Pin terminal thickness : 0.3±0.1
- ※ Pin terminal material : Copper alloy
- ※ Plating treatment of terminal : Lead free plating
- ※ Case thickness : 0.2±0.05
- ※ Case material : Brass
- ※ Plating treatment of case : Nickel plating
- ※ Please keep enough creepage distance with the pattern on PCB and other components.
- ※ Mass 10g less

SUCW10