

UNCONTROLLED DOCUMENT

CAUTION: PRESSURE SENSITIVE ASSEMBLY  
AVOID APPLYING PRESSURE TO LED  
DURING PANEL ASSEMBLY.

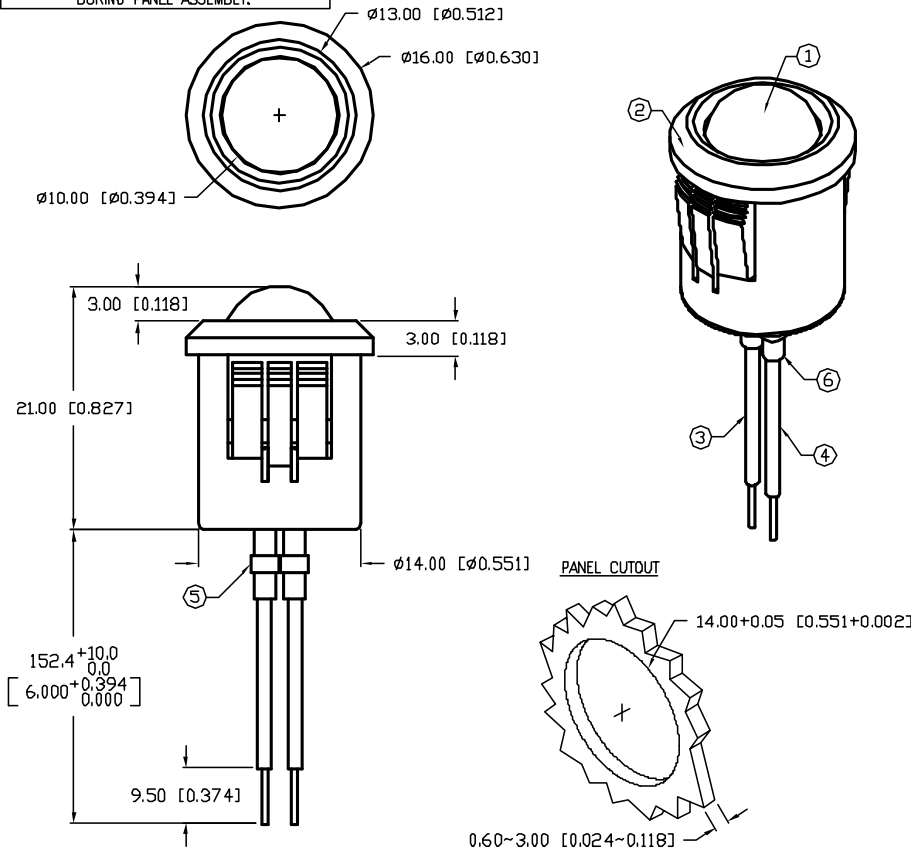

\*UNLESS OTHERWISE SPECIFIED TOLERANCES PER DECIMAL PRECISION ARE: X=±1 (±0.039), XX=±0.5 (±0.020), XXX=±0.25 (±0.010), XXXX=±0.127 (±0.005). LEAD SIZE=±0.05 (±0.002), LEAD LENGTH=±0.75 (±0.030), MIN=+DECIMAL PRECISION -0.00, MAX.=+0.00 -DECIMAL PRECISION

PART NUMBER  
SSI-LXH1090USBD150

REV.

CAUTION: STATIC SENSITIVE DEVICE  
FOLLOW PROPER E.S.D. HANDLING PROCEDURES  
WHEN WORKING WITH THIS PART.

ELECTRO-OPTICAL CHARACTERISTICS  $T_A=25^{\circ}\text{C}$   $I_f=20\text{mA}$

PARAMETER	MIN	TYP	MAX	UNITS	TEST COND
PEAK WAVELENGTH		470		nm	
FORWARD VOLTAGE		3.5	4.0	$V_f$	
REVERSE VOLTAGE	5.0			$V_r$	$I_f=100\mu\text{A}$
AXIAL INTENSITY		350		mcd	$I_f=20\text{mA}$
VIEWING ANGLE		60		2x theta	
EMITTED COLOR:	BLUE				
EPOXY LENS FINISH:	BLUE DIFFUSED				

LIMITS OF SAFE OPERATION AT 25°C

PARAMETER	MAX	UNITS
PEAK FORWARD CURRENT*	100	mA
STEADY CURRENT	30	mA
POWER DISSIPATION	100	mW
DERATE FROM 25°C	-1.2	mW/°C
OPERATING, STORAGE TEMP.	-40 TO +85	°C

\*  $t < 10\mu\text{s}$

NOTES:

- SSL-LX100133USBD LED.
- SSH-RTF1090 HOLDER.
- ANODE LEAD: LXP-WST24RDT0C, 24 AWG STRANDED, RED INSULATION, CUT 144mm LONG, STRIP 3mm & 9.5mm.
- CATHODE LEAD: LXP-WST24BLT0C, 24 AWG STRANDED, BLACK INSULATION, CUT 144mm LONG, STRIP 3mm & 9.5mm.
- CRIMP WIRE LEADS TO LED LEADS.
- 2 PIECES- 32mm, 1/16" BLACK HEAT SHRINK TUBING.
- UV EPOXY TO RETAIN LED IN HOLDER.

UNCONTROLLED DOCUMENT

REV. PART NUMBER  
SSI-LXH1090USBD150

CONFIDENTIAL INFORMATION  
THE INFORMATION CONTAINED IN THIS DOCUMENT IS THE PROPERTY OF LUMEX INC. EXCEPT AS SPECIFICALLY AUTHORIZED IN WRITING BY LUMEX INC., THE HOLDER OF THIS DOCUMENT SHALL KEEP ALL INFORMATION CONTAINED HEREIN CONFIDENTIAL AND SHALL PROTECT SAME IN WHOLE OR IN PART FROM DISCLOSURE AND DISSEMINATION TO ALL THIRD PARTIES.



290 E. HELEN ROAD  
PALATINE, IL 60067-6976  
PHONE: +1.847.359.2790  
US WEB: www.lumex.com  
TW WEB: www.lumex.com.tw

T-10mm 470nm InGaN/SiC BLUE LED PANEL INDICATOR,  
BLUE DIFFUSED LENS, 6" WIRE LEADS.

RELIABILITY NOTE  
OUR MANY YEARS OF EXPERIENCE DATA ACCUMULATION INDICATE THAT SOLDER HEAT IS A MAJOR CAUSE OF EARLY AND FUTURE FAILURE. PLEASE PAY ATTENTION TO YOUR SOLDERING PROCESS.

DRAWN BY: BC	CHECKED BY:	APPROVED BY:	DATE: 1.5.02
			PAGE: 1 OF 1
			SCALE: N/A