

### Differential Positive ECL (DPECL) SN-A2970 Series

PRELIMINARY

#### Description

The **SN-A2970 Series** of quartz crystal oscillators provide DPECL Fast Edge compatible signals. This device is to operate using positive voltage and uses multiple ground pins for improved signal integrity. This device is intended to operate on positive voltage for PECL applications.

#### Features

- Wide frequency range—671.0MHz to 1.7GHz
- User specified tolerance available
- Case at electrical ground
- All metal, resistance weld, hermetically sealed package
- High shock resistance, to 1500g
- Low Jitter - Wavecrest jitter characterization available
- High Reliability - NEL HALT/HASS qualified for crystal oscillator start-up conditions
- Overtone technology
- High Q Crystal actively tuned oscillator circuit
- Power supply decoupling internal
- Dual ground plane for added stability
- No internal PLL avoids cascading PLL problems
- High frequencies due to proprietary design
- RoHS Compliant, Lead Free Construction

#### Electrical Connection

Pin	Connection
1	V <sub>EE</sub> Ground
2	V <sub>CC</sub>
7	Output
8	/Output
9	V <sub>EE</sub> Ground
10	V <sub>CC</sub>
15	V <sub>CC</sub>
16	V <sub>EE</sub> Ground

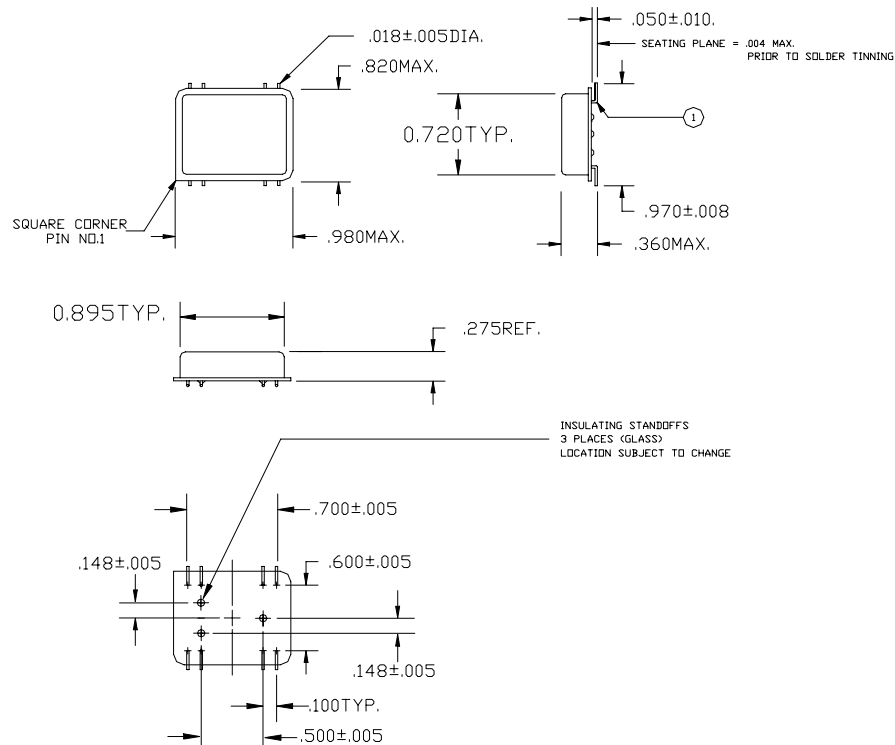

ALL DIMENSIONS  
ARE IN INCHES

SN-A2970 Series Continued  
Differential Positive ECL (DPECL)

Rev. D

## Operating Conditions and Output Characteristics

### Electrical Characteristics

Parameter	Symbol	Conditions	Min	Typical	Max
Frequency	-----	-----	671.0MHz	-----	1.7GHz
Duty Cycle	-----	@ 50% points	45/55%	-----	55/45%
Logic 0 <sup>(2)</sup>	V <sub>OL</sub>	-----	V <sub>CC</sub> -1.95V	-----	V <sub>CC</sub> -1.60V
Logic 1 <sup>(2)</sup>	V <sub>OH</sub>	-----	V <sub>CC</sub> -1.02V	-----	V <sub>CC</sub> -0.74V
Rise & Fall Time	tr,tf	20-80%V <sub>O</sub> with 50 ohm load to V <sub>CC</sub> -2V	-----	300 psec	400 psec
Jitter, RMS <sup>(3)</sup>	-----	-----	-----	3 psec	-----
Enable Voltage <sup>(4)</sup>	-----	with V <sub>EE</sub> =0V	0V	-----	1.0V
Disable Voltage	-----	with V <sub>EE</sub> =0V	3.0V	-----	V <sub>CC</sub>
Frequency Stability <sup>(1)</sup>	dF/F	Overall conditions including: voltage, calibration, temp., 10 yr aging, shock, vibration	-100ppm	-----	+100ppm

### General Characteristics

Parameter	Symbol	Conditions	Min	Typical	Max
Supply Voltage	V <sub>CC</sub>	3.3V±5%	3.135V	3.3V	3.465V
Supply Current	I <sub>CC</sub>	50 ohm termination To 2.00V below V <sub>CC</sub>	0.0 mA	-----	300 mA
Output current	I <sub>O</sub>	Low level Output Current	0.0 mA	-----	±50.0 mA
Operating temperature	T <sub>A</sub>	-----	0°C	-----	70°C
Storage temperature	T <sub>S</sub>	-----	-55°C	-----	125°C
Input: Logic High (ECL) - Disables V <sub>EE</sub> or Open - Enables					
Load		50 Ohm to V <sub>CC</sub> -2V or Thevenin Equivalent, Bias Required			
Start-up time	t <sub>S</sub>	-----	-----	2 ms	10 ms

### Environmental and Mechanical Characteristics

Mechanical Shock	Per MIL-STD-202, Method 213, Condition E
Thermal Shock	Per MIL-STD-883, Method 1011, Condition A
Vibration	0.060" double amplitude 10 Hz to 55 Hz, 35g's 55Hz to 2000 Hz
Hermetic Seal	Leak rate less than 1 x 10 <sup>-8</sup> atm.cc/sec of helium

#### Footnotes:

- Standard frequency stability (±20,±25,±50ppm & others available)
- V<sub>OL</sub>, V<sub>OH</sub>, referenced to ground
- Jitter performance is frequency dependent. Please contact factory for full Wavecrest characterization. RMS jitter bandwidth of 12kHz to 20MHz.
- Open to Enable pin also enables to output.

Creating a Part Number	
<b>SN - A297X - FREQ</b>	
<b>Package Code</b>	<b>Tolerance/Performance</b>
HN Leaded 8 pin (16pin)	0 ±100ppm 0-70°C
SN 8 pin (16 pin) SMD Gull Wing	1 ±50ppm 0-70°C
	7 ±25ppm 0-70°C
<b>Input Voltage</b>	9 Customer Specific
Code Specification	A ±20ppm 0-70°C
A 3.3V	B ±50ppm -40 to +85°C
5V	C ±100ppm -40 to +85°C

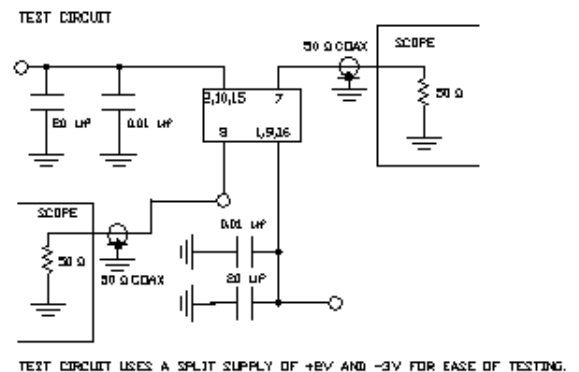

SN-A2970 Series Continued

Max Reflow Profile

