

PRELIMINARY
 Notice: This is not a final specification.
 Some parametric limits are subject to change.

MITSUBISHI SOFT RECOVERY DIODE

FD1500CV-90DA

HIGH POWER, HIGH FREQUENCY
 PRESS PACK TYPE

FD1500CV-90DA



- VRRM Repetitive peak reverse voltage 4500V
- IT(AV) Average on-state current 1200A

OUTLINE DRAWING

Dimensions in mm

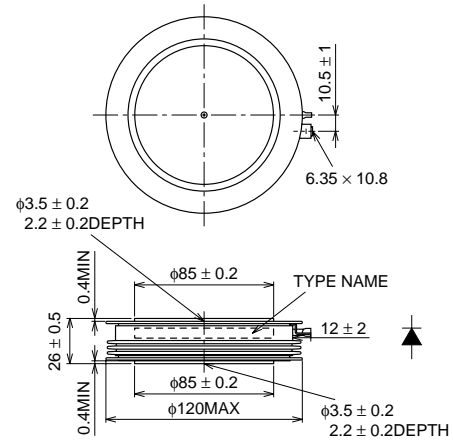

APPLICATION

- High-power inverters
- Fly-hwheel diode for GCT Thyristor
- Power supplies as high frequency rectifiers

MAXIMUM RATINGS

Symbol	Parameter	Conditions	Voltage class	Unit
VRRM	Repetitive peak reverse voltage	—	4500	V
VRSM	Non-repetitive peak reverse voltage	—	4500	V
VR(DC)	DC reverse voltage	—	3600	V
V(LTDS)	Long term DC stability voltage	—	3000	V

Symbol	Parameter	Conditions	Ratings	Unit
IF(RMS)	RMS forward current	Applied for all condition angles	1900	A
IF(AV)	Average forward current	f = 60Hz, sinewave $\theta = 180^\circ$, $T_f = 74^\circ\text{C}$	1200	A
IFSM	Surge forward current	One half cycle at 60Hz, $T_j = 125^\circ\text{C}$ start	26	kA
I ² t	Current-squared, time integration		2.8×10^6	A ² s
di/dt	Critical rate of rise of reverse recovery current	IFM = 1500A, VR = 2250V, $T_j = 25/125^\circ\text{C}$ Cc = 6 μF , Lc = 0.3 μH (See Fig. 1, 2)	1000	A/ μs
Tj	Operation junction temperature		-40 ~ 125	$^\circ\text{C}$
Tstg	Storage temperature		-40 ~ 150	$^\circ\text{C}$
—	Mounting force required	(Recommended value 47kN)	39 ~ 55	kN
—	Weight	Typical value 1450g	—	g

ELECTRICAL CHARACTERISTICS

Symbol	Parameter	Test conditions	Limits			Unit
			Min.	Typ.	Max.	
VFM	Forward voltage	IFM = 3400A, $T_j = 125^\circ\text{C}$	—	—	5	V
IRRM	Repetitive peak reverse current	VRM = 4500V, $T_j = 125^\circ\text{C}$	—	—	150	mA
QRR	Reverse recovery charge	IFM = 1500A, di/dt = 1000A/ μs , VR = 2250V, $T_j = 125^\circ\text{C}$	—	—	4000	μC
Erec	Reverse recovery energy	Cc = 6 μF , Lc = 0.3 μH (See Fig. 1, 2)	—	—	7	J/P
Rth(j-f)	Thermal resistance	Junction to Fin	—	—	0.0071	K/W

Jul. 2002



FD1500CV-90DA

HIGH POWER, HIGH FREQUENCY
PRESS PACK TYPE

PRELIMINARY
Notice: This is not a final specification.
Some parametric limits are subject to change.

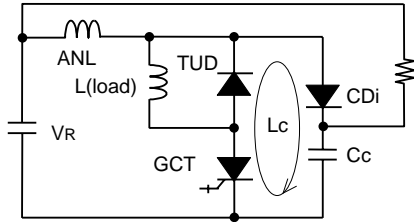

Fig. 1 Reverse recovery test circuit

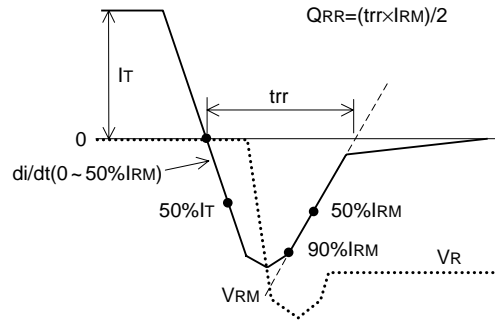

Fig. 2 Reverse recovery waveform

PERFORMANCE CURVES

