

Features

- Low-Power 3.3V CMOS Design
- On-Board 5V to 3.3V Voltage Regulator
- Single 12 MHz Crystal
- USB Specification 1.1 Compliant.
- WHQL Certified
- Supports Data Rates from 75 bps to 3 Mbps
- External RS-232 Transceiver Shut Down
- Re-configurable Vendor Specific Parameters (Vendor-ID, Product-ID, Release #)
- Support for 4 string descriptors (Language-ID, Manufacture-ID, Product Name, Serial Number)
- Supports Remote-Wakeup and Power Management Features
- I²C Interface for EEPROM
- Low-profile 28-Pin SSOP Package

General Description

The MCS7703 controller provides bridging between the Universal Serial Bus (USB) input and an enhanced UART port. This device contains all the necessary logic to communicate with the host computer via the USB Bus.

In addition, the MCS7703 contains a 3.3V regulator and operates in Bus-Powered mode.

The MCS7703 uses a single 12 MHz crystal oscillator. This combination of features allows significant cost savings in system design along with straightforward implementation of Serial Port functionality into PC peripherals using the host's USB port.

Applications

- Cell Phone Interface Cable
- Serial Networking
- High-Speed Modems
- Monitoring Equipment

Application Note

- AN-7703

Evaluation Board

- MCS7703-EVB



Ordering Information

Ordering Information		
Commercial Grade (0° C to +70° C)		
MCS7703CS	28-SSOP	Standard
MCS7703CS-GR	28-SSOP	RoHS

MCS7703

USB 1.1 to Single Serial Port



Block Diagram

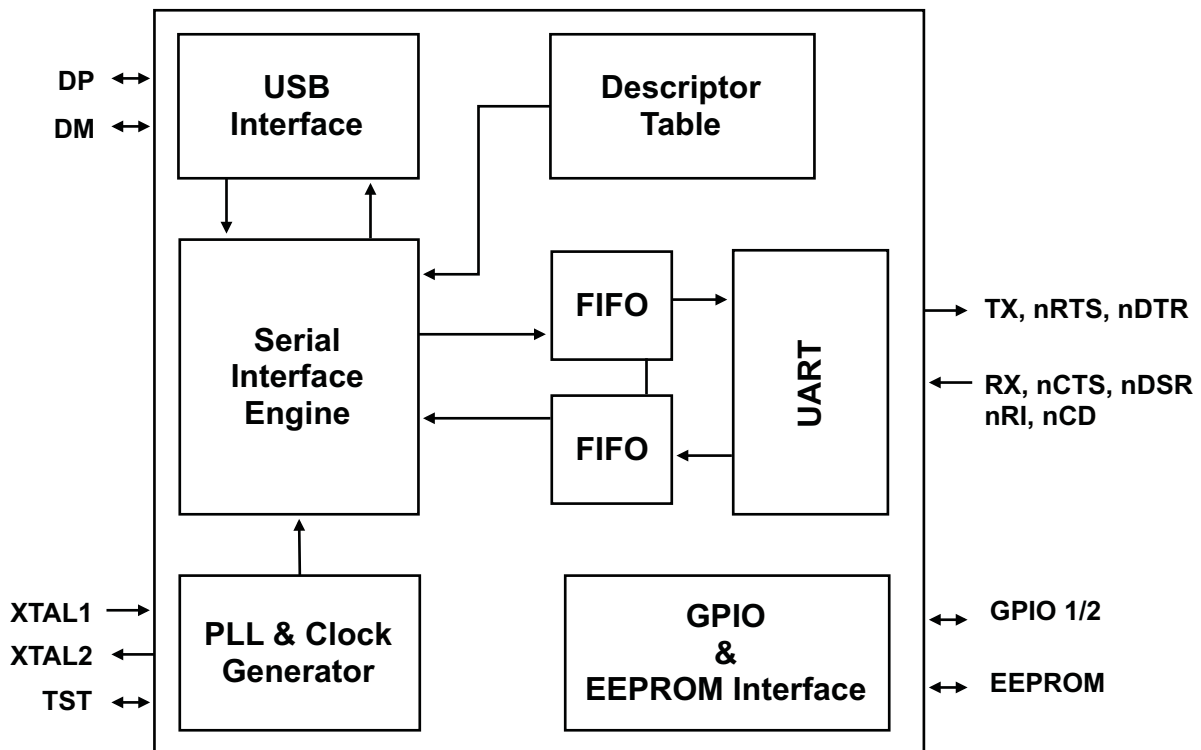

28-Pin SSOP Package

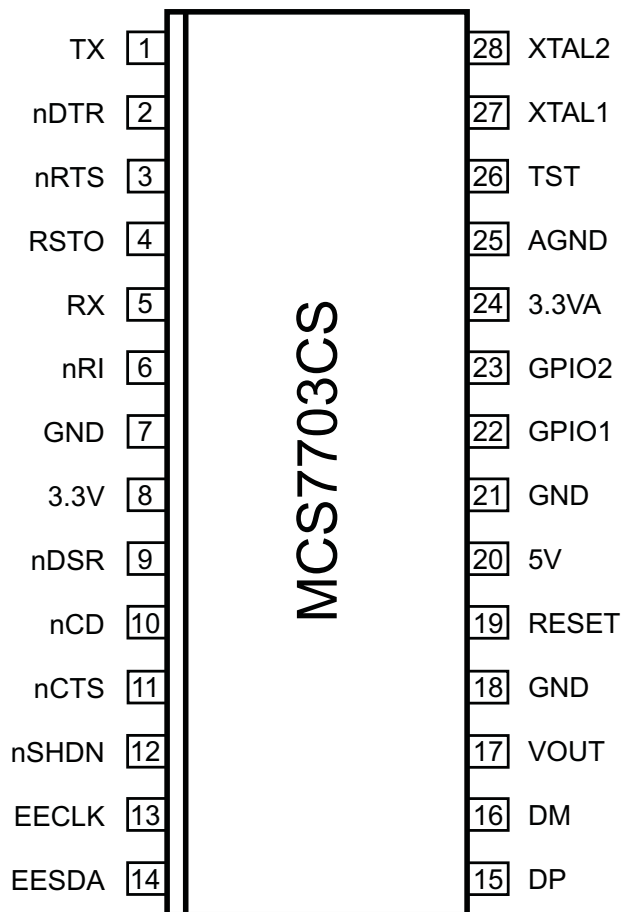

MCS7703

USB 1.1 to Single Serial Port



Pin Name	Pin	Type	Description
TX	1	O	Serial Data Output.
nDTR	2	O	Data-Terminal-Ready signal. It is set high (inactive) after a hardware reset or during internal loop-back mode. When low, this output indicates to the modem or data set that the UART is ready to establish a communication link. nDTR has no effect on the transmitter or receiver.
nRTS	3	O	Request-To-Send signal. It is set high (inactive) after a hardware reset or during internal loop-back mode. When low, this indicates the PC is ready to exchange data.
RSTO	4	O	Power-On Reset output. Output of the internal Power-On Reset is routed to this pin.
RX	5	I	Serial Data Input.
nRI	6	I	Ring-detect signal.
nDSR	9	I	Data-Set-Ready signal.
nCD	10	I	Carrier-Detect signal. When low this indicates that the modem or data set has detected the data carrier. nCD has no effect on the transmitter.
nCTS	11	I	Clear-To-Send signal. When low this indicates that the modem or data set is ready to exchange data. nCTS has no effect on the transmitter.
nSHDN	12	O	Shut Down External RS-232 transceiver. Active Low, when DCR2 Bit-7 = 0, Active High, when DCR2 Bit-7 = 1. Default is active low.
EECLK	13	I/O	2-Wire EEPROM Clock.
EESDA	14	I/O	2-Wire EEPROM Data IN/OUT. Tri-State.
DP	15	I/O	Upstream USB port differential Data Plus (D+), analog.
DM	16	I/O	Upstream USB port differential Data Minus (D-), analog.
VOUT	17	PWR	+3.3V Voltage Regulator Output.
RESET	19	I	System Reset. Resets all internal registers, sequencers, and signals to a consistent state. Active High.
5V	20	PWR	Main power input. Connect to USB VBUS or local VDD.
GPIO1	22	I/O	If DCR0 Bit-1 = 0, then GPIO is Tri-State after Reset. When DCR0 Bit-1 = 1, Bi-directional GPIO pin.
GPIO2	23	I/O	If DCR0 Bit-1 = 0, at Reset the state of this pin is used to decide the load condition. Low is 100mA, High is 500mA. When DCR0 Bit-1 = 1, Bi-directional GPIO pin.
AGND	25	PWR	PLL Analog Ground.

Pin Name	Pin	Type	Description
TST	26	I	Internal Test Mode (internal pull-up). When this pin is tied to 3.3V, the internal Test Mode is enabled. Low for normal operation.
XTAL1	27	I	Crystal oscillator or external clock input
XTAL2	28	O	Crystal oscillator output. See XTAL1 description.
GND	7, 18, 21	PWR	Power and Signal Ground.
3.3VA	24	PWR	Analog 3.3V Power Supply
3.3V	8	PWR	Device Supply Input, to be connected to VOUT pin when 5V supply is used.

Note: All names with “n” prefix are active low.

MCS7703

USB 1.1 to Single Serial Port



Functional Description

The MCS7703 consists of two major functional blocks, the USB Controller and the Serial Interface. The USB Controller provides Control, Bulk-In, and Bulk-Out endpoints to the USB host. The Serial Interface consists of transmit and receive blocks that connect to an external RS-232 transceiver.

USB Interface

The USB interface to the Host Controller includes a Control endpoint, a Bulk-In endpoint, a Bulk-Out endpoint, and an Interrupt endpoint. The USB controller supports the USB 1.1 specification. Hence, it supports all standard functionality associated with device enumeration, standard USB device requests, etc. In addition, there is a set of Vendor Specific commands provided to allow a USB driver to access registers and ROM in the USB controller.

EEPROM Interface

The MCS7703 uses an optional external EEPROM to load Vendor Specific parameters. The EEPROM is connected through a convenient 2-wire I²C interface.

After Power-On Reset, the MCS7703 reads two Bytes from the EEPROM. If the two Bytes are equal to 9710 (hex) then it recognizes the EEPROM as being present and the next 8 Bytes are read. Otherwise the MCS7703 reverts to its default operating mode using default values.

If the EEPROM is present, the following data will be loaded into the MCS7703 registers.

Byte	Byte Count	Name	Description
1-0	2	EE Check	EEPROM Present Check, (9710).
3-2	2	VID	Vendor-ID (9710)
5-4	2	PID	Product-ID (7703)
7-6	2	RN	Release Number in BCD format (0001)
10-8	3	DCR	Device Configuration Register (DCR)
12-11	2	Language-ID	Language-ID in Hex format (0409)
60-13	48	Manufacture-ID	"MosChip Semiconductor" in UNICODE
102-61	42	Product Name	"USB-Serial Controller" in UNICODE
118-103	16	Serial Number	"XXXXXXXX" in UNICODE

Device Configuration

The table below describes the function of each bit in the three Control Registers. In the absence of the EEPROM the default values are used for device configuration.

Device Control Register 0:

Register	Bit	Name	Description
DCR0	0	RS_SDM	RS-232 Transceiver shut down mode: 0 = Normal Operation 1 = Shut Down the transceiver when USB Suspend is engaged (default).
	1	GPIO_1_Tri	GPIO-1 Pin State: 0 = Tri-Mode input (default). 1 = Assign as GPIO pin
	2-3	GPIO_Mode	(Default 00)
	4-5	RTS_CM	(Default 00)
	6	Mode Select	0 = RS-232 Serial mode (default). 1 = Not Used
	7	8/16 Mode	0 = Standard Serial Port (default). 1 = 16-bit Serial Character mode.

MCS7703

USB 1.1 to Single Serial Port



Device Control Register 1:

Register	Bit	Name	Description
DCR1	0-1	GPIO_PMG	GPIO output current settings. 00 = 6mA 01 = 8mA (default) 10 = 10mA 11 = 12mA
	2-3	TX_PMG	Transmit output current settings. 00 = 6mA 01 = 8mA (default) 10 = 10mA 11 = 12mA
	4	Wakeup	Remote Wakeup: 0 = Enable USB Remote Wakeup (default). 1 = Disable USB Remote Wakeup.
	5-7	RSVD	Reserved (Default = 000)

Device Control Register 2:

Register	Bit	Name	Description
DCR2	0	WK_CTS	CTS Wakeup Function: 0 = Disabled (default) 1 = Wakeup will trigger on CTS state change
	1	WK_CD	CD Wakeup Function: 0 = Disabled (default) 1 = Wakeup will trigger on CD state change
	2	WK_RI	RI Wakeup function: 0 = Disabled. 1 = Wakeup will trigger on RI state change (default)
	3	WK_DSR	DSR Wakeup Function: 0 = Disabled (default) 1 = Wakeup will trigger on DSR state change
	4	WK_RX	RX Wakeup Function: 0 = Disabled (default) 1 = Wakeup will trigger on RX state change
	5	WK_RO	Remote Wakeup Function: 0 = Enable Remote Wakeup, disconnect signal. 1 = Wakeup, MCS7703 issues Resume Signal (default)
	6	RSTO	External RS-232 Three-State Control: 0 = Disabled (default) 1 = Enabled
	7	SHDN	nSHDN Pin Polarity: 0 = Active Low (default) 1 = Active High

MCS7703

USB 1.1 to Single Serial Port



Absolute Maximum Ratings

Supply Range	6.0 Volts
Voltage At Any Pin	GND - 0.3 to VCC + 0.3
Operating Temperature	-45° C to +90° C
Storage Temperature	-65° C to +150° C
Package Dissipation	500 mW
ESD	±2000 Volts
Latch up	220 mA

DC Electrical Specifications

Temp = 0° C to +70° C; Vcc = 3.3V ±10% unless otherwise specified.

Symbol	Parameter	Min	Max	Unit	Condition
5.0V	Voltage Regulator Input Supply	4.5	5.5	V	
3.3V	Operating Supply Voltage	3.0	3.6	V	
Vclk _L	Clock Input (low level)	-0.5	0.6	V	External
Vclk _H	Clock Input (high level)	2.4	Vcc	V	External
V _{iL}	Input (low level)		1.08	V	CMOS
V _{iH}	Input (high level)	2.1		V	CMOS
V _{oL}	Output (low level)		0.4	V	I _{oL} = 6 mA
V _{oH}	Output (high level)	1.85		V	I _{oH} = 6 mA
I _{iL}	Input Leakage Current	-10	+10	µA	
I _{cc}	Operating Current	12	25	mA	From 3.3V Supply
I _{reg}	Regulator Current		45	mA	From +5V Supply
C _p	Input Pin Capacitance	5	7	pF	

AC Electrical Specifications

Temp = 0° C to +70° C; Vcc = 3.3V ±10% unless otherwise specified.

Symbol	Parameter	Min	Max	Unit	Condition
CLKA	USB clock frequency	12	12	MHz	±50 PPM

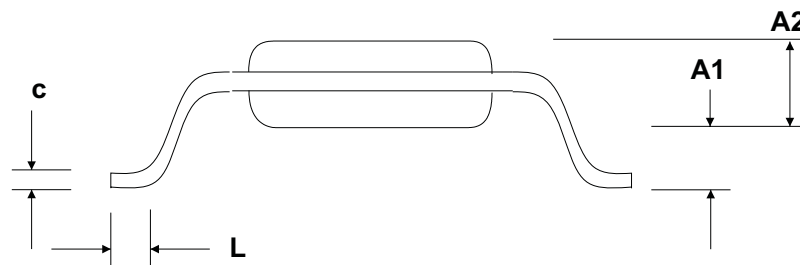
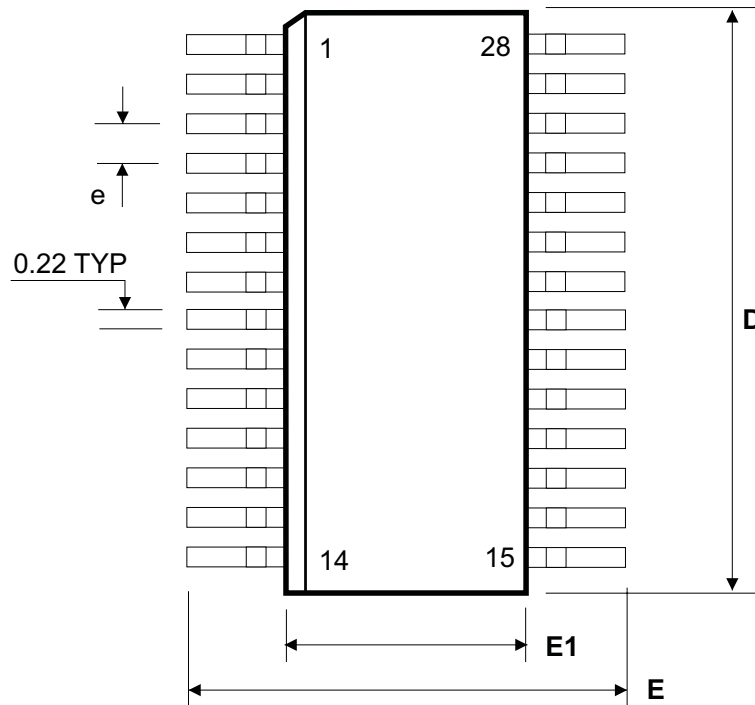

**28-Pin SSOP
Package Dimensions**

SYMBOL	MILLIMETERS			INCHES		
	MIN	TYP	MAX	MIN	TYP	MAX
A1	0.05		0.21	0.020		0.08
A2	1.65		1.80	0.650		0.708
C			0.25			
e		0.65			0.026	
D	10.00		10.4	3.93		4.09
E	7.4	7.8	8.2			
E1	5.2		5.4	2.05		2.12
L	0.55	0.75	0.95			

MCS7703

USB 1.1 to Single Serial Port



IMPORTANT NOTICE

MosChip Semiconductor Technology, LTD products are not authorized for use as critical components in life support devices or systems. Life support devices are applications that may involve potential risks of death, personal injury or severe property or environmental damages. These critical components are semiconductor products whose failure to perform can be reasonably expected to cause the failure of the life support systems or device, or to adversely impact its effectiveness or safety. The use of MosChip Semiconductor Technology LTD's products in such devices or systems is done so fully at the customer risk and liability.

As in all designs and applications it is recommended that the customer apply sufficient safeguards and guard bands in both the design and operating parameters. MosChip Semiconductor Technology LTD assumes no liability for customer's applications assistance or for any customer's product design(s) that use MosChip Semiconductor Technology, LTD's products.

MosChip Semiconductor Technology, LTD warrants the performance of its products to the current specifications in effect at the time of sale per MosChip Semiconductor Technology, LTD standard limited warranty. MosChip Semiconductor Technology, LTD imposes testing and quality control processes that it deems necessary to support this warranty. The customer should be aware that not all parameters are 100% tested for each device. Sufficient testing is done to ensure product reliability in accordance with MosChip Semiconductor Technology LTD's warranty.

MosChip Semiconductor Technology, LTD believes the information in this document to be accurate and reliable but assumes no responsibility for any errors or omissions that may have occurred in its generation or printing. The information contained herein is subject to change without notice and no responsibility is assumed by MosChip Semiconductor Technology, LTD to update or keep current the information contained in this document, nor for its use or for infringement of patent or other rights of third parties. MosChip Semiconductor Technology, LTD does not warrant or represent that any license, either expressed or implied, is granted to the user.

Revision History

Revision	Changes	Date
1.1	Corrections	Feb-2004
1.2	AC/DC Characteristics	Mar-2004
1.3	Pin Name Correction on the 28-Pin SSOP Package	Mar-2004
1.4	PL2303X and 6MHz Removed From Feature List	Apr-2004
1.5	Changes to Document Layout	30-Nov-2005
1.6	Corrected Block Diagram	12-Dec-2005