

RM300DG-90S

HIGH POWER SWITCHING USE
INSULATED TYPE

High Voltage Diode Module

RM300DG-90S



- IF300A
- VRRM4500V
- High Insulated Type
- 2-element in a Pack
- AISiC Baseplate

APPLICATION

Traction drives, High Reliability Converters / Inverters, DC choppers

OUTLINE DRAWING & CIRCUIT DIAGRAM

Dimensions in mm

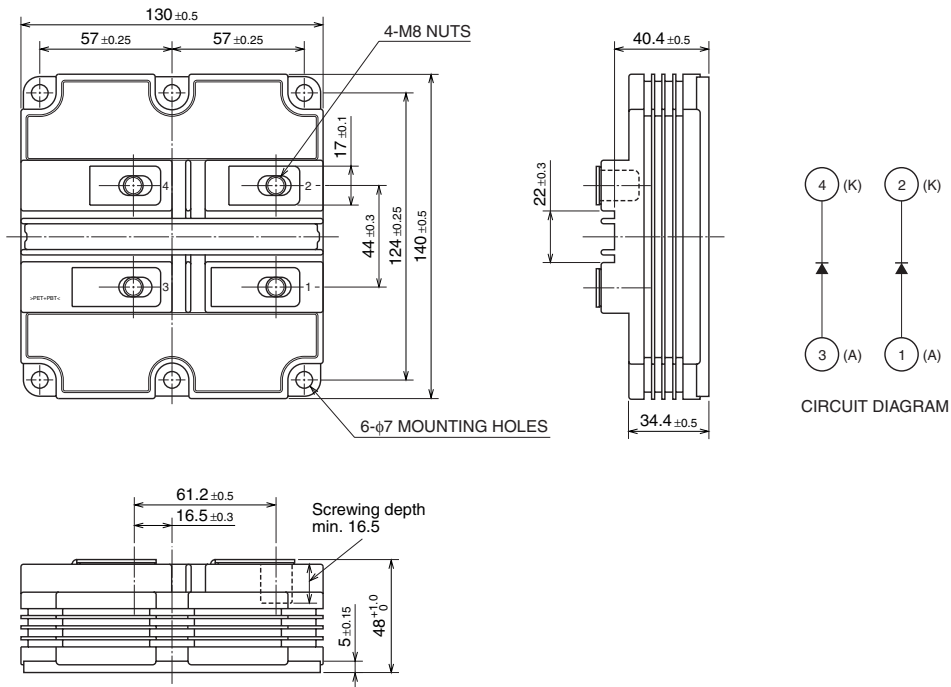

High Voltage Diode Module

May 2009

RM300DG-90S

**HIGH POWER SWITCHING USE
INSULATED TYPE**

High Voltage Diode Module

MAXIMUM RATINGS

Symbol	Item	Conditions	Ratings	Unit
VRRM	Repetitive peak reverse voltage	T _j = 25 °C	4500	V
VRSM	Non-repetitive peak reverse voltage	T _j = 25 °C	4500	V
VR(DC)	Reverse DC voltage	T _j = 25 °C	3000	V
IF	DC forward current	T _c = 25 °C	300	A
IFSM	Surge forward current	T _j = 25 °C start, t _w = 8.3 ms Half sign wave	2400	A
I ² t	Current-squared, time integration	T _j = 25 °C start, t _w = 8.3 ms Half sign wave	24	kA ² s
V _{iso}	Isolation voltage	Charged part to the baseplate RMS sinusoidal, 60Hz 1min.	10200	V
V _e	Partial discharge extinction voltage	RMS sinusoidal, 60Hz, QPD ≤ 10PC	5100	V
T _j	Junction temperature	—	-40 ~ +150	°C
T _{op}	Operating temperature	—	-40 ~ +125	°C
T _{stg}	Storage temperature	—	-40 ~ +125	°C

ELECTRICAL CHARACTERISTICS

Symbol	Item	Conditions	Limits			Unit	
			Min	Typ	Max		
IRRM	Repetitive reverse current	V _{RM} = VRRM	T _j = 25 °C	—	—	1	mA
			T _j = 125 °C	—	0.5	10	
VFM	Forward voltage (Note 1)	I _F = 300 A	T _j = 25 °C	—	4.80	—	V
			T _j = 125 °C	—	4.15	—	
t _{rr}	Reverse recovery time	V _R = 2250 V, I _F = 300 A di/dt = -800 A/μs L _s =100nH, T _j = 125 °C	—	1.0	—	μs	
I _{rr}	Reverse recovery current		—	280	—	A	
Q _{rr}	Reverse recovery charge		—	250	—	μC	
E _{rec}	Reverse recovery energy (Note 2)		—	0.33	—	J/P	

Note 1. It doesn't include the voltage drop by internal lead resistance.
2. E_{rec} is the integral of 0.1V_R x 0.1I_{rr} x dt.

RM300DG-90S

**HIGH POWER SWITCHING USE
INSULATED TYPE**

High Voltage Diode Module

THERMAL CHARACTERISTICS

Symbol	Item	Conditions	Limits			Unit
			Min	Typ	Max	
Rth(j-c)	Thermal resistance	Junction to case (per 1/2 module)	—	—	66.0	K/kW
Rth(c-f)	Contact thermal resistance	Case to Fin, $\lambda_{grease} = 1W/m\cdot K$ D(c-f)=100 μm , (per 1/2 module)	—	48.0	—	K/kW

MECHANICAL CHARACTERISTICS

Symbol	Item	Conditions	Limits			Unit
			Min	Typ	Max	
Mt	Mounting torque	M8: Main terminals screw	7.0	—	15.0	N·m
Ms		M6: Mounting screw	3.0	—	6.0	N·m
m	Mass	—	—	1.0	—	kg
CTI	Comparative tracking index	—	600	—	—	—
Da	Clearance	—	26	—	—	mm
Ds	Creepage distance	—	56	—	—	mm
LP CE	Internal inductance	—	—	44	—	nH
RCC'+EE'	Internal lead resistance	Tc = 25 °C	—	0.27	—	m Ω

PERFORMANCE CURVES

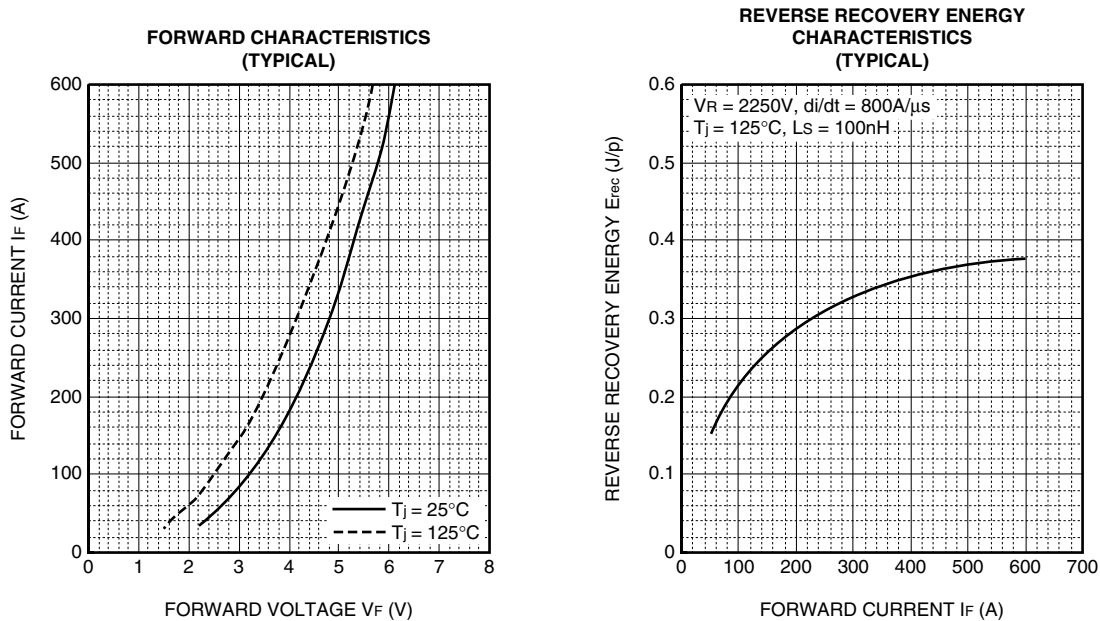

RM300DG-90S

**HIGH POWER SWITCHING USE
INSULATED TYPE**

High Voltage Diode Module

REVERSE RECOVERY CHARACTERISTICS (TYPICAL)

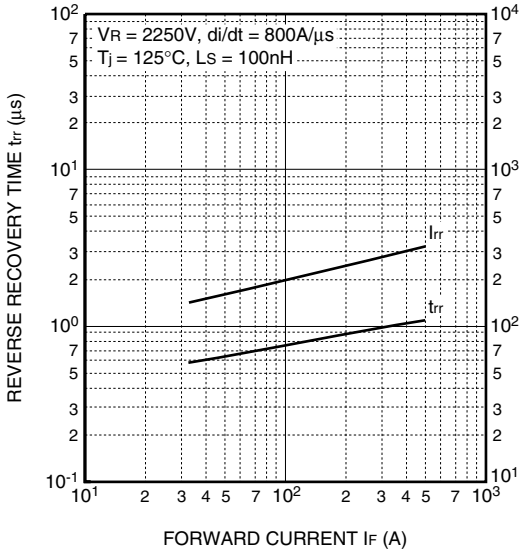

REVERSE RECOVERY SAFE OPERATING AREA (RRSOA)

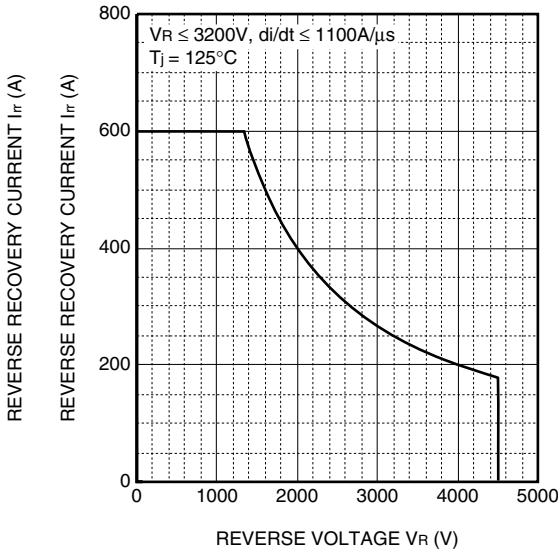

TRANSIENT THERMAL IMPEDANCE CHARACTERISTICS

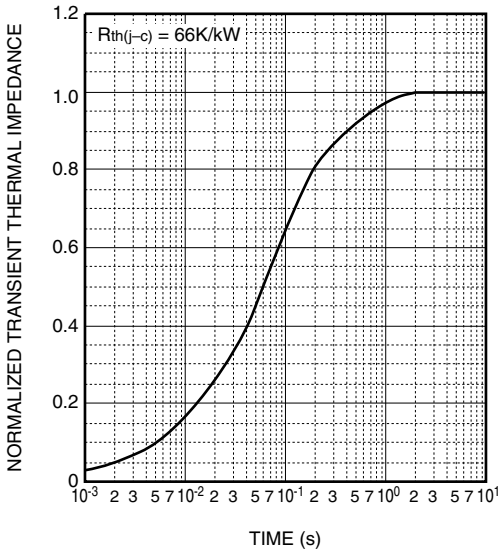

$$Z_{th(j-c)}(t) = \sum_{i=1}^n R_i \left\{ 1 - \exp\left(-\frac{t}{\tau_i}\right) \right\}$$

	1	2	3	4
R_i [K/kW]	0.0059	0.0978	0.6571	0.2392
τ_i [sec]	0.0002	0.0074	0.0732	0.4488

High Voltage Diode Module

May 2009

