



# 25 - 105 Amp • THYRISTOR/DIODE Module

## Features

- Industry Standard Package and Circuits
- Power Control Building Blocks

## DESCRIPTION

Modules come in an industry standard package, offering three circuits that can be used singly or as power control building blocks. All models feature highly efficient thermal management for greatly extended cycle life.

## PART NUMBER IDENTIFICATION

Ex.: CSKT92/16E

Series Type	Circuit Type	Current	Voltage
CSK -Case style	(see schematic diagrams) Example: T	27 - 25 Amps 42 - 40 Amps 57 - 55 Amps 92 - 90 Amps 106 - 105 Amps	08E - 800 10E - 1000 12E - 1200 14E - 1400 16E - 1600

## ELECTRICAL SPECIFICATIONS

SYMBOL	SPECIFICATION	27	42	5	92	106
$I_D$	Maximum DC Output Current ( $T_c = 85^\circ\text{C}$ ) [A]	25	40	55	90	105
$V_F$	Maximum Voltage Drop	1.55V @ 75Apk	1.4V @ 120Apk	1.4V @ 165Apk	1.4V @ 270Apk	1.65V @ 300Apk
$T_J$	Operating Junction Temperature Range	-40°C to +125°C				
di/dt	Critical Rate of Rise of On-State Current @ $T_J=125^\circ\text{C}$ [A/ $\mu\text{s}$ ]	100	100	100	100	100
dv/dt	Critical Rate of Rise of Off-State Voltage [V/ $\mu\text{s}$ ]	1000	1000	1000	1000	1000
$V_{RRM}$	Repetitive Peak Reverse Voltage (AC Line Nominal) [Vpk]	400 (120 Vac) 600 (240 Vac) 1000 (380 Vac) 1200 (480 Vac) 1400 (530 Vac) 1600 (600 Vac)				
$I_{TSM}$	Maximum Non-Repetitive Surge Current ( $1/2$ Cycle, 60Hz) [A]	400	1000	1500	1950	2250
$I^2T$	Maximum $I^2T$ for Fusing ( $t=8.3\text{ms}$ ) [A <sup>2</sup> sec]	670	4150	9350	15800	25000
$I_{GT}$	Maximum Required Gate Current to Trigger @ 25°C [mA]	150	150	150	150	150
$V_{GT}$	Maximum Required Gate Voltage to Trigger @ 25°C [V]	3.0	3.0	3.0	3.0	3.0
$P_{G(AV)}$	Average Gate Power [W]	0.5	0.5	0.5	0.5	0.5
$V_{GM}$	Maximum Peak Gate Voltage (Reverse) [V]	5.0	5.0	5.0	5.0	5.0
$R_{qJC}$	Maximum Thermal Resistance Junction to Ceramic Base per Chip [°C/W]	0.4	0.28	0.25	0.14	0.135
$V_{ISOL}$	Isolation Voltage [ $V_{RMS}$ ]	2500	2500	2500	2500	2500

## MECHANICAL SPECIFICATIONS

Weight: (typical)	4.75 oz. (135g)
Torque Required	Terminal Stud Screw : 30 inch lb Mounting Screw : 20 inch lb

© C3 Semiconductors, LLC. All rights are reserved

For recommended applications and more information contact:  
 USA: Sales Support (888) 882-8689  
 C3 Semiconductors, LLC. 2320 Paseo de las Americas, Ste. 104, San Diego, CA 92154  
 Email: sales@c3semi.com WEB SITE: <http://www.C3semi.com>



# 25 - 105 Amp • THYRISTOR/DIODE Module

## Features

- Industry Standard Package and Circuits
- Power Control Building Blocks

## DESCRIPTION

Modules come in an industry standard package, offering three circuits that can be used singly or as power control building blocks. All models feature highly efficient thermal management for greatly extended cycle life.

## MECHANICAL DIMENSIONS All dimensions are in millimeters (inches)

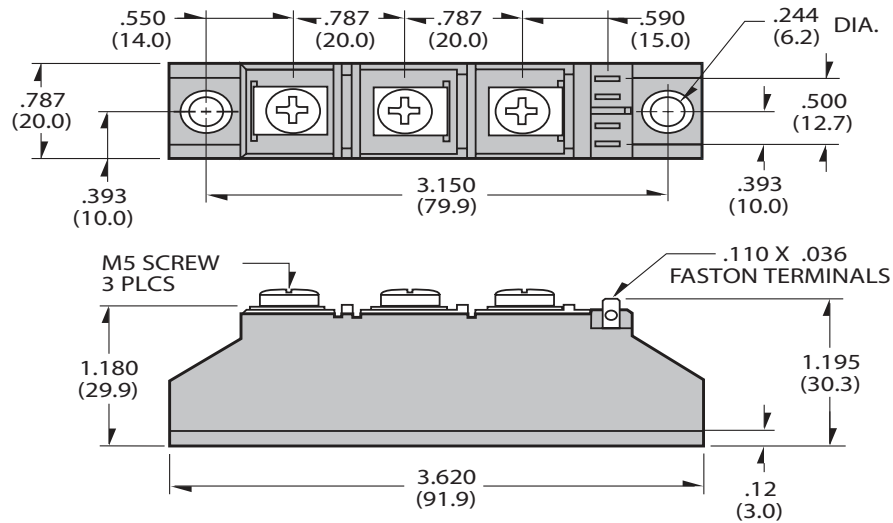

## CSK SERIES CIRCUITS

