

Control integrated Power System (CIPOS™)

IKCS12G60DA

IKCS12G60DC

<http://www.infineon.com/cipos>

Power Management & Drives



N e v e r s t o p t h i n k i n g .

Revision History:	2009-04	Rev.2.3
Previous Version:	2.2	
Page	Subjects (major changes since last revision)	
4	Added UL certification	
10	Change $V_{IT,HYS}$	
14	Updated Zth-diagram of diode	

Authors: W. Frank, W. Brunnbauer

Edition 2007-11

**Published by
Infineon Technologies AG
85579 Neubiberg, Germany**

**© Infineon Technologies AG 4/6/09.
All Rights Reserved.**

Attention please!

The information given in this data sheet shall in no event be regarded as a guarantee of conditions or characteristics ("Beschaffenheitsgarantie"). With respect to any examples or hints given herein, any typical values stated herein and/or any information regarding the application of the device, Infineon Technologies hereby disclaims any and all warranties and liabilities of any kind, including without limitation warranties of non-infringement of intellectual property rights of any third party.

Information

For further information on technology, delivery terms and conditions and prices please contact your nearest Infineon Technologies Office or representatives (<http://www.infineon.com>).

Warnings

Due to technical requirements components may contain dangerous substances. For information on the types in question please contact your nearest Infineon Technologies Office or representatives.

Infineon Technologies Components may only be used in life-support devices or systems with the express written approval of Infineon Technologies, if a failure of such components can reasonably be expected to cause the failure of that life-support device or system, or to affect the safety or effectiveness of that device or system. Life support devices or systems are intended to be implanted in the human body, or to support and/or maintain and sustain and/or protect human life. If they fail, it is reasonable to assume that the health of the user or other persons may be endangered.

TrenchStop® is a registered trademark of Infineon Technologies AG.

CIPOS™, CoolMOS™, CoolSET™, DuoPack™ and thinQ!™ are trademarks of Infineon Technologies AG.

Table of Contents

CiPoS™ Control integrated Power System	4
Features.....	4
Target Applications	4
Description	4
System Configuration	4
Internal Electrical Schematic.....	5
Pin Assignment.....	6
Pin Description	6
/HIN1,2,3 and /LIN1,2,3 (Low side and high side control pins, Pin 15 - 20)	6
EN, /FAULT (Pin 21)	7
TEMP (Temperature monitor, Pin 22)	7
ITRIP (Over-current detection, Pin 13).....	7
VDD, VSS (control side supply and reference, Pin 14, 23).....	7
VB1,2,3 and VS1,2,3 (High side supplies, Pin 1, 2, 4, 5, 7, 8).....	7
V+ (positive bus input voltage, Pin 10).....	7
Sh (shunt negative potential, Pin 12)	7
Absolute Maximum Ratings	8
Module Section	8
IGBT and Diode Section	8
Control Section	9
Recommended Operation Conditions.....	9
Static Characteristics.....	10
Dynamic Characteristics.....	11
Integrated Components	12
Circuit of a Typical Application.....	12
Integrated Components	13
Test Circuits and Parameter Definition	15
Package Outline IKCS12G60DA	17
Package Outline IKCS12G60DC	18

CIPOS™

Control integrated Power System

Single In-Line Intelligent Power Module with integrated Shunt
3Φ-bridge 600V / 12A @ 25°C

Features

- Infineon TrenchStop® IGBTs with lowest $V_{CE(sat)}$
- Optimal adapted EmCon™ diode for low EMI
- Integrated bootstrap diode and capacitor
- Rugged SOI gate driver technology with stability against transient and negative voltage
- Current measurement shunt integrated
- Overcurrent shutdown
- Temperature monitor
- Undervoltage lockout at all channels
- Fault-signal
- Matched propagation delay for all channels
- Cross-conduction prevention
- Lead-free terminal plating; RoHS compliant
- Qualified according to JEDEC¹ (high temperature stress tests for 1000h) for target applications

Target Applications

- Washing machines
- Consumer Fans and Consumer Compressors

Description

The CIPOS™ module family offers the chance for integrating various power and control components to increase reliability, optimize PCB size and system costs.

This SIL-IPM is designed to control AC motors in variable speed drives for applications like air conditioning, compressors and washing machines. The package concept is specially adapted to power applications, which need extremely good thermal conduction and electrical isolation, but also EMI-save control and overload protection. The features of Infineon TrenchStop® IGBTs and EmCon diodes are combined with a new optimized Infineon SOI gate driver for excellent electrical performance. The integrated shunt improves the overall performance of the module.

System Configuration

- 3 halfbridges with TrenchStop® IGBT & FW-EmCon diodes
- 3Φ SOI gate driver
- Bootstrap diodes for high side supply
- Integrated 100nF bootstrap capacitance
- Temperature sensor, passive components for adaptations
- Isolated heatsink
- Creepage distance typ. 3.2mm

Certification

UL 1577 (UL file E314539)

¹ J-STD-020 and JESD-022

Internal Electrical Schematic

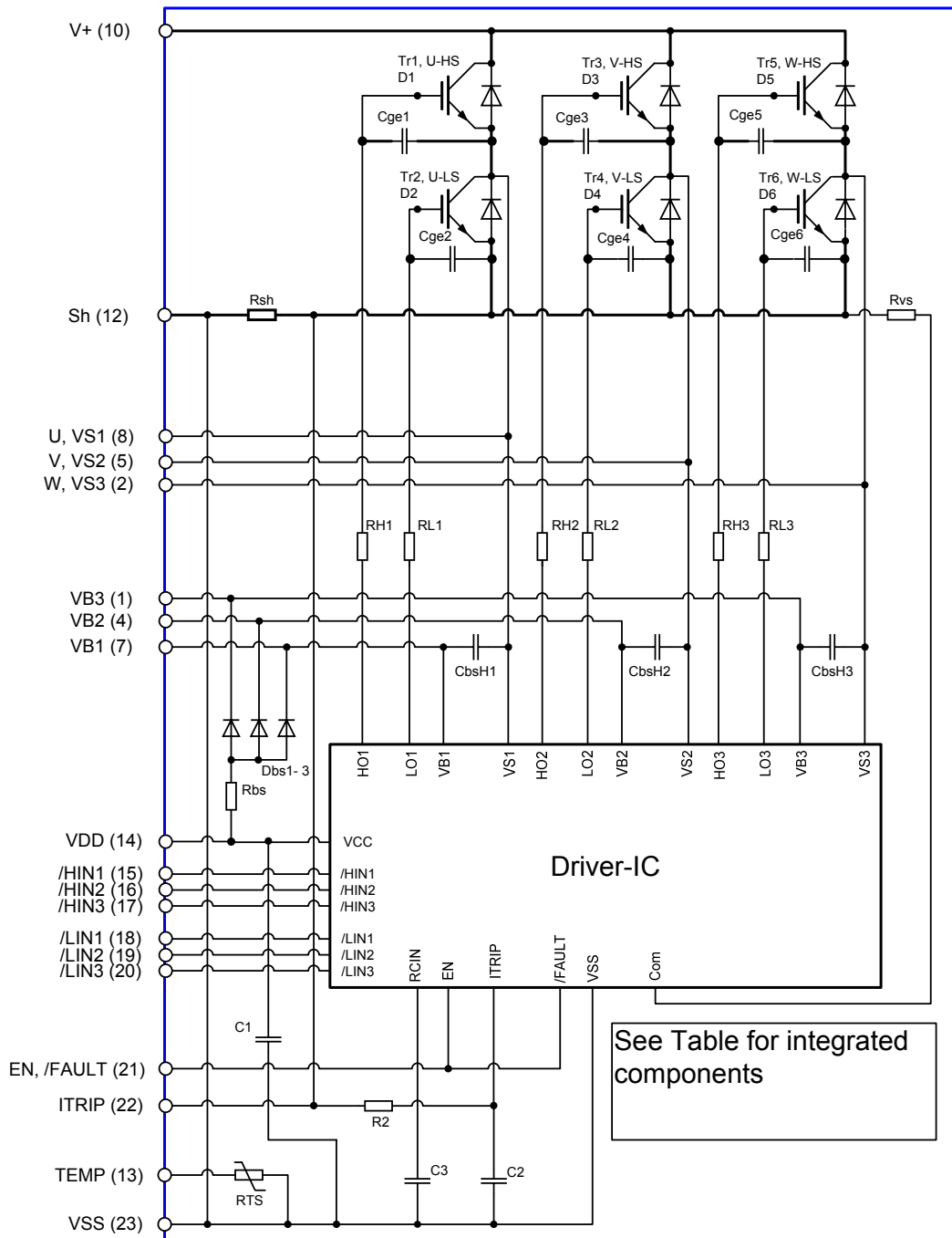

Figure 1: Internal Schematic

Pin Assignment

Pin Number	Pin Name	Pin Description
1	VB3	high side floating IC supply voltage
2	W,VS3	motor output W, high side floating IC supply offset voltage
3	na	none
4	VB2	high side floating IC supply voltage
5	V,VS2	motor output V, high side floating IC supply offset voltage
6	na	none
7	VB1	high side floating IC supply voltage
8	U,VS1	motor output U, high side floating IC supply offset voltage
9	na	none
10	V+	positive bus input voltage
11	na	none
12	Sh	closed low side emitter with internal shunt
13	TEMP	temperature control
14	VDD	IC main supply +15V
15	/HIN1	input gate driver high side 1/U
16	/HIN2	input gate driver high side 2/V
17	/HIN3	input gate driver high side 3/W
18	/LIN1	input gate driver low side 1/U
19	/LIN2	input gate driver low side 2/V
20	/LIN3	input gate driver low side 3/W
21	EN, /FAULT	input logic enable, indicates over-current and under-voltage (negative logic, open-drain output)
22	ITRIP	input overcurrent shutdown
23	VSS	IC negative supply

Pin Description

/HIN1,2,3 and /LIN1,2,3 (Low side and high side control pins, Pin 15 - 20)

These pins are active low and they are responsible for the control of the integrated IGBT. The Schmitt-trigger input threshold of them are

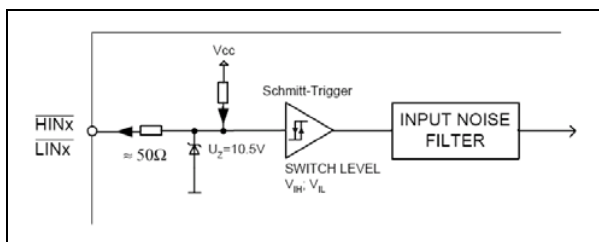

Figure 2: Input pin structure

such to guarantee LSTTL and CMOS compatibility down to 3.3V controller outputs. Pull-up resistor of about 75 kΩ is internally provided to pre-bias inputs during supply start-up and a zener clamp is provided for pin protection purposes. Input schmitt-trigger and noise filter provide beneficial noise rejection to short input pulses.

It is recommended for proper work of CIPOS™ not to provide input pulse-width lower than 1μs.

The integrated gate drive provides additionally a shoot through prevention capability which avoids the simultaneous on-state of two gate drivers of the same leg (i.e. HO1 and LO1, HO2 and LO2, HO3 and LO3).

A minimum deadtime insertion of typ 380ns is also provided, in order to reduce cross-conduction of the external power switches.

EN, /FAULT (Pin 21)

The signal applied to pin EN controls directly the output stages. All outputs are set to LOW, if EN is at LOW logic level. The internal structure of the pin is the same as Figure 2 made exception of the switching levels of the Schmitt-Trigger, which are here $V_{EN,TH+} = 2.1\text{ V}$ and $V_{EN,TH-} = 1.3\text{ V}$. The typical propagation delay time is $t_{EN} = 900\text{ ns}$. A pull-down resistor of typ. $75\text{ k}\Omega$ keeps the system off in case of lack of control signal.

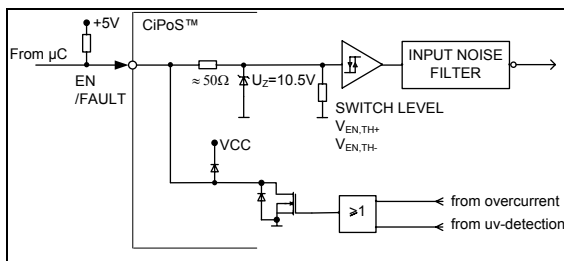

Figure 3: Internal Circuit at pin EN

This pin is also used for indication of exceptional conditions, such as overcurrent or undervoltage of the control section of the gate drive IC. The on-resistance of the internal open-drain FET is typically 56Ω .

TEMP (Temperature monitor, Pin 22)

The integrated NTC-resistor is given in section Integrated Components.

ITRIP (Over-current detection, Pin 13)

The overcurrent signal is provided by the integrated shunt resistor. CIPOS™ provides an over-current detection function. The integrated ITRIP comparator threshold (typ 0.46 V) is referenced to VSS ground. An input noise filter (typ: $t_{ITRIPMIN} = 225\text{ ns}$) prevents the driver to detect false over-current events. The over-current detection generates a hard shut down of all outputs of the gate driver after the propagation delay of typically 900 ns .

As soon as the overcurrent detector triggers, the /FAULT signal is activated, which pulls down the enable pin.

VDD, VSS (control side supply and reference, Pin 14, 23)

VDD is the low side supply and it provides power both to input logic and to low side output power

stage. Input logic is referenced to VSS ground as well as the under-voltage detection circuit.

The under-voltage circuit enables the device to operate at power on when a supply voltage of at least a typical voltage of $V_{DDUV+} = 12.1\text{ V}$ is at least present.

The IC shuts down all the gate drivers power outputs, when the VCC supply voltage is below $V_{DDUV-} = 10.4\text{ V}$. This prevents the external power switches from critically low gate voltage levels during on-state and therefore from excessive power dissipation.

VB1,2,3 and VS1,2,3 (High side supplies, Pin 1, 2, 4, 5, 7, 8)

VB to VS is the high side supply voltage. The high

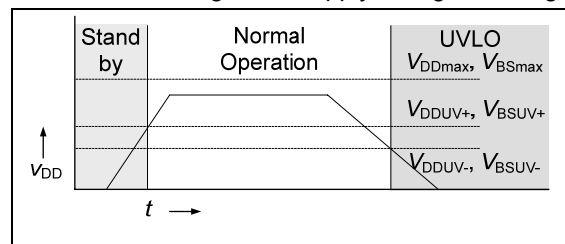

Figure 4: Input filter timing diagram

side circuit can float with respect to VSS following the external high side power device emitter/source voltage.

Due to the low power consumption, the floating driver stage is supplied by an integrated bootstrap circuit connected to VDD. This includes also integrated bootstrap capacitors of 100 nF at each floating supply, which are located very close to the gate drive circuit.

The under-voltage detection operates with a rising supply threshold of typical $V_{BSUV+} = 12.1\text{ V}$ and a falling threshold of $V_{DDUV-} = 10.4\text{ V}$ according to Figure 4.

VS1,2,3 provide a high robustness against negative voltage in respect of VSS of -50 V . This ensures very stable designs even under rough conditions.

V+ (positive bus input voltage, Pin 10)

The high side IGBT are connected to the bus voltage. It is recommended, that the bus voltage does not exceed 500 V .

Sh (shunt negative potential, Pin 12)

This pin is the available terminal of the shunt resistor, which is usually connected to the reference voltage of CIPOS™.

Absolute Maximum Ratings

($T_c = 25^\circ\text{C}$, $V_{DD} = 15\text{V}$, if not stated otherwise)

Module Section

Description	Condition	Symbol	Value		Unit
			Min	max	
Storage temperature range		T_{stg}	-40	125	$^\circ\text{C}$
Operating temperature control PCB ¹		T_{PCB}	-	125	$^\circ\text{C}$
Solder temperature	Wave soldering, 1.6mm (0.063in.) from case for 10s	T_{sol}	-	260	$^\circ\text{C}$
Insulation test voltage	RMS, $f=50\text{Hz}$, $t=1\text{min}$	V_{ISOL}	2500	-	V
Mounting torque	M3 screw and washer	M_S	-	0.6	Nm
Mounting pressure on surface	Package flat on mounting surface	N_{MC}	-	150	N/mm ²
Creepage distance		d_S	3.1	-	mm
Max. peak power of bootstrap resistor	$t_p = 100\mu\text{s}$ $T_c = 100^\circ\text{C}$	P_{BRpeak}		90	W

IGBT and Diode Section

Description	Condition	Symbol	Value		Unit
			min	max	
Max. Blocking Voltage		V_{CES}	600	-	V
DC output current	$T_c = 25^\circ\text{C}$, $T_{vj} < 150^\circ\text{C}$ $T_c = 80^\circ\text{C}$, $T_{vj} < 150^\circ\text{C}$	I_u , I_v , I_w	-12 -6	12 6	A
Repetitive peak collector current	t_p limited by T_{vjmax}	I_u , I_v , I_w	-18	18	A
Short circuit withstand time ² (SCSOA)	$V_{DD} = 15\text{V}$, $V_{DC} = 400\text{V}$, $T_{vj} = 150^\circ\text{C}$	t_{sc}	-	5	μs
IGBT reverse bias safe operating area (RBSOA)	$V_{DD} = 15\text{V}$, $V_{DC} \leq 500\text{V}$, $T_{vj} = 150^\circ\text{C}$, $I_C = 6\text{A}$ $V_{CEmax} = 600\text{V}$		Full Square		
Power dissipation per IGBT	$T_c = 25^\circ\text{C}$	P_{tot}	-	35	W
Operating junction temperature range	IGBT Diode	T_{vjI} T_{vjD}	-40 -40	150 150	$^\circ\text{C}$

¹ Monitored by pin 13

² Allowed number of short circuits: <1000; time between short circuits: >1s.

Description	Condition	Symbol	Value			Unit
			min	typ	max	
Single IGBT thermal resistance, junction-case		R_{thJC}	-	-	3.0	K/W
Single diode thermal resistance, junction-case		R_{thJCD}	-	-	4.2	

Control Section

Description	Condition	Symbol	Value		Unit
			min	max	
Module supply voltage		V_{DD}	-1	20	V
High side floating supply voltage (VB vs. VS)		V_{BS}	-1	20	
High side floating IC supply offset voltage	$t_p < 500ns$	$V_{S1,2,3}$	VDD-VBS-6 VDD-VBS-50	600	V
Input voltage	LIN, HIN, EN, ITRIP	V_{in}	-1	10	V
Operating junction temperature ¹		$T_{J,IC}$	-	125	
Max. switching frequency		f_{PWM}	-	20	kHz

Recommended Operation Conditions

All voltages are absolute voltages referenced to V_{SS} -Potential unless otherwise specified.

Description	Symbol	Value		Unit
		min	max	
High side floating supply offset voltage	V_S	-3	500	V
High side floating supply voltage (V_B vs. V_S)	V_{BS}	12.5	17.5	
High side output voltage (V_{HO} vs. V_S)	V_{HO}	0	V_{BS}	
Low side power supply	V_{DD}	12.5	17.5	
Logic input voltages LIN,HIN,EN,ITRIP	V_{IN}	0	5	

¹ Monitored by pin 13

Static Characteristics

($T_c = 25^\circ\text{C}$, $V_{DD} = 15\text{V}$, if not stated otherwise)

Description	Condition	Symbol	Value			Unit
			min	typ	max	
Collector-Emitter breakdown voltage	$V_{IN} = 5\text{V}$, $I_C = 0.25\text{ mA}$	$V_{(BR)CES}$	600	-	-	V
Collector-Emitter saturation voltage	$V_{DD} = 15\text{V}$, $I_{out} = \pm 6\text{A}$ $T_{vj} = 25^\circ\text{C}$ $T_{vj} = 150^\circ\text{C}$	$V_{CE(sat)}$	- -	1.6 1.9	2.1	V
Diode forward voltage	$V_{IN} = 5\text{V}$, $I_{out} = \pm 6\text{A}$ $T_{vj} = 25^\circ\text{C}$ $T_{vj} = 150^\circ\text{C}$	V_F	- -	1.65 1.6	2.05	V
Zero gate voltage collector current of IGBT	$V_{CE} = 600\text{V}$, $V_{IN} = 5\text{V}$ $T_{vj} = 25^\circ\text{C}$ $T_{vj} = 150^\circ\text{C}$	I_{CES}	- -	- -	40 1000	μA
Short circuit collector current ¹	$V_{DD} = 15\text{V}$, $t_{SC} \leq 5\mu\text{s}$ $V_{CC} = 400\text{V}$, $T_{vj} = 150^\circ\text{C}$	$I_{C(SC)}^2$	-	40	-	A
Logic "0" input voltage (LIN,HIN)		V_{IH}	1.7	2.1	2.4	V
Logic "1" input voltage (LIN,HIN)		V_{IL}	0.7	0.9	1.1	V
EN positive going threshold		$V_{EN,TH+}$	1.9	2.1	2.3	V
EN negative going threshold		$V_{EN,TH-}$	1.1	1.3	1.5	V
ITRIP positive going threshold		$V_{IT,TH+}^2$	360	460	540	mV
ITRIP input hysteresis		$V_{IT,HYS}^2$	45	75	-	mV
V_{DD} and V_{BS} supply undervoltage positive going threshold		V_{DDUV+}^2 V_{BSUV+}^2	11.0	12.1	12.8	V
V_{DD} and V_{BS} supply undervoltage negative going threshold		V_{DDUV-}^2 V_{BSUV-}^2	9.5	10.4	11.0	V
V_{CC} and V_{BS} supply undervoltage lockout hysteresis		V_{DDUVH}^2 V_{BSUVH}^2	1.2	1.7	-	V
Input clamp voltage (/HIN, /LIN, EN, ITRIP)	$I_{IN} = 4\text{ mA}$	$V_{INCLAMP}$	9.0	10.1	13.0	V
Quiescent V_{Bx} supply current (V_{Bx} only)	$V_{HIN} = \text{low}$	I_{QB}	-	360	550	μA
Quiescent VDD supply current (VDD only)	$V_{IN} = \text{float}$	I_{QDD}	-	2.0	3.0	mA
Input bias current	$V_{IN} = 5\text{V}$	I_{IN+}	-	55	100	μA
Input bias current	$V_{IN} = 0\text{V}$	I_{IN-}	-	110	200	μA
EN Input bias current	$V_{EN} = 5\text{V}$	I_{EN+}	-	62	120	μA
Leakage current of high side	$T_{j,IC} = 125^\circ\text{C}$	I_{LVS}^2	-	30	-	μA

¹ Allowed number of short circuits: <1000; time between short circuits: >1s.

² Test is not subject of product test, verified by characterisation

Dynamic Characteristics

($T_c = 25^\circ\text{C}$, $V_{DD} = 15\text{V}$, if not stated otherwise)

Description	Condition	Symbol	Value			Unit
			min	typ	max	
Turn-on propagation delay High side or low side	$V_{LIN,HIN} = 0\text{V}$; $I_{out} = 6\text{A}$, $V_{DC} = 300\text{V}$	$t_{d(on)}$	-	638	-	ns
Turn-on rise time High side or low side	$I_{out} = 6\text{A}$, $V_{DC} = 300\text{V}$ $V_{LIN,HIN} = 5\text{V}$	t_r	-	22	-	ns
Turn-off propagation delay High side or low side	$V_{LIN,HIN} = 5\text{V}$; $I_{out} = 6\text{A}$, $V_{DC} = 300\text{V}$	$t_{d(off)}$	-	812	-	ns
Turn-off fall time High side or low side	$I_{out} = 6\text{A}$, $V_{DC} = 300\text{V}$ $V_{LIN,HIN} = 0\text{V}$	t_f	-	30	-	ns
Shutdown propagation delay ENABLE	$V_{EN} = 0\text{V}$, I_u , I_v , $I_w = 6\text{A}$	t_{EN}	-	900	-	ns
Shutdown propagation delay ITRIP	$V_{ITRIP} = 1\text{V}$, I_u , I_v , $I_w = 6\text{A}$	t_{ITRIP}	-	900	-	ns
Input filter time ITRIP	$V_{ITRIP} = 1\text{V}$	$t_{ITRIPmin}$	155	210	380	ns
Input filter time at LIN for turn on and off and input filter time at HIN for turn on only	$V_{LIN,HIN} = 0\text{V} \& 5\text{V}$	t_{FILIN}	120	270	-	ns
Input filter time at HIN for turn off	$V_{HIN} = 5\text{V}$	t_{FILIN1}	-	220	-	ns
Input filter time at HIN for turn off	$V_{HIN} = 5\text{V}$	t_{FILIN2}	-	400	-	ns
Input filter time EN		t_{FILEN}	300	430	-	ns
Fault clear time after ITRIP-fault	$V_{LIN,HIN} = 0\text{V} \& 5\text{V}$ $V_{ITRIP} = 0\text{V}$	t_{FLTCLR}	-	4.7	-	ms
Min. deadtime between low side and high side		DT_{PWM}	-	1	-	μs
Deadtime of gate drive circuit		DT_{IC}	-	380	-	ns
IGBT Turn-on Energy (includes reverse recovery of diode)	$I_{out} = 6\text{A}$, $V_{DC} = 300\text{V}$ $T_{vj} = 25^\circ\text{C}$ $T_{vj} = 150^\circ\text{C}$	E_{on}	-	89	-	μJ
IGBT Turn-off Energy	$I_{out} = 6\text{A}$, $V_{DC} = 300\text{V}$ $T_{vj} = 25^\circ\text{C}$ $T_{vj} = 150^\circ\text{C}$	E_{off}	-	123	-	μJ
Diode recovery Energy	$I_{out} = 6\text{A}$, $V_{DC} = 300\text{V}$ $T_{vj} = 25^\circ\text{C}$ $T_{vj} = 150^\circ\text{C}$	E_{rec}	-	22	-	μJ
			-	59	-	

Integrated Components

Description	Condition	Symbol ¹	Value			Unit
			min	typ	max	
Resistor (0.25 W)		Rbs	-	10	-	Ω
Shunt-Resistor		Rsh	-	20	-	mΩ
Resistor		R2	-	0.47		kΩ
Resistor	$T_{NTC} = 25^{\circ}\text{C}$	RTS	-	100	-	
B-Constant of NTC (Negative Temperature Coefficient)	$T_{NTC} = 25^{\circ}\text{C}$	B25	-	4250	-	K
Bootstrap diode forward voltage	$I_{FDbs} = 1\text{A}, T_J = 25^{\circ}\text{C}$	V_{FDbs}	-	1.3	-	V
Capacitor		C1	-	100	-	nF
Capacitor		C2	-	2.2	-	
Capacitor		C3		2.2		
Bootstrap Capacitor		C_{bsH_x}	-	100	-	
Capacitor		C_{gex}		390		pF

Circuit of a Typical Application

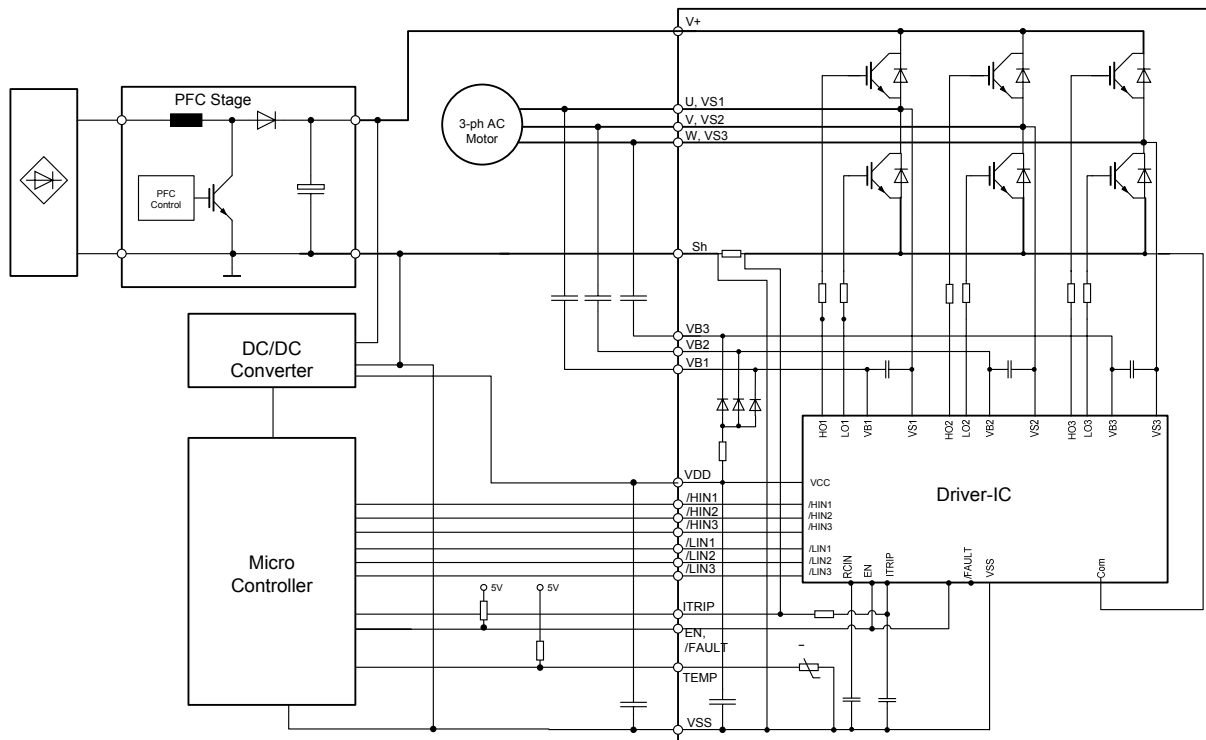

¹ Symbols according to Figure 1

Integrated Components

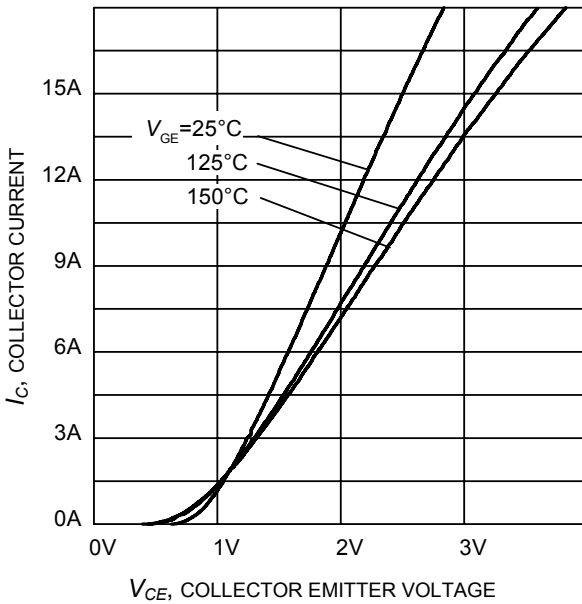

Figure 5. Typical IGBT output characteristic
($V_{DD} = 15V$)

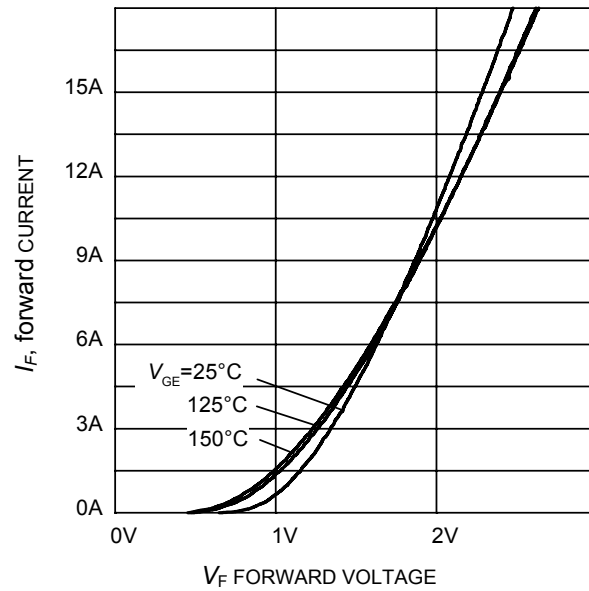

Figure 6. Typical diode forward current as a function of forward voltage

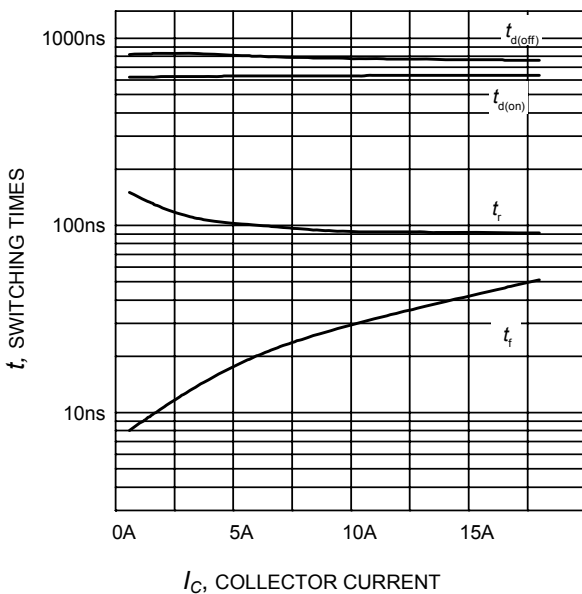

Figure 7. Typical switching times as a function of collector current
(inductive load, $T_J = 150^\circ C$, $V_{CE} = 300V$, $V_{DD} = 15V$
Dynamic test circuit in Figure A)

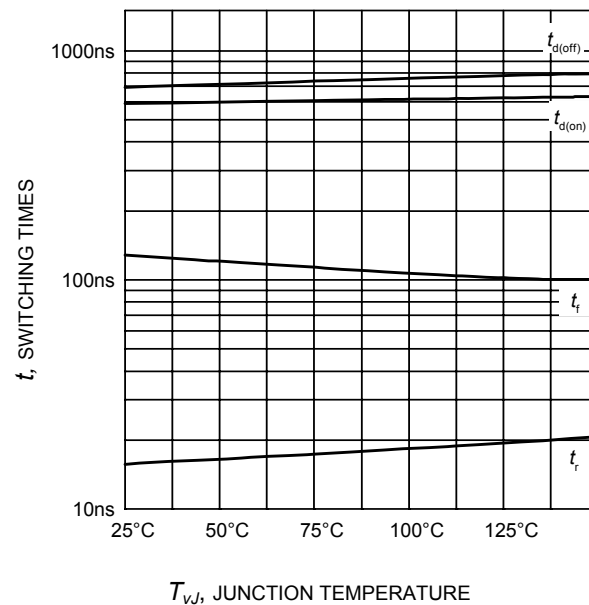

Figure 8. Typical switching times as a function of junction temperature
(inductive load, $V_{CE} = 300V$, $V_{DD} = 15V$, $I_C = 6A$
Dynamic test circuit in Figure A)

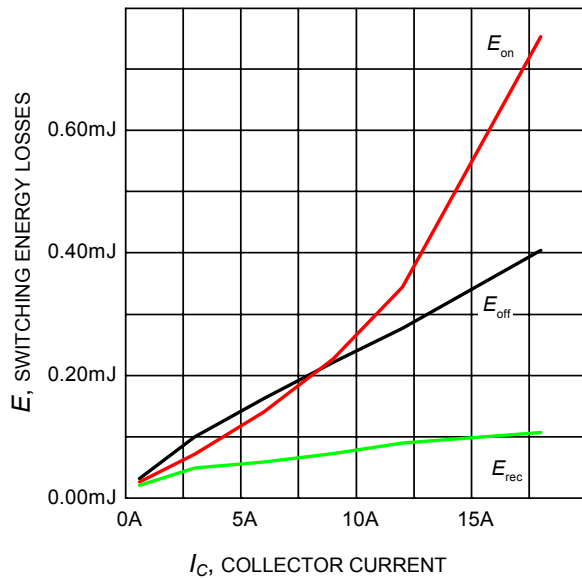

Figure 9. Typical switching energy losses as a function of collector current
(inductive load, $T_J = 150^\circ\text{C}$,
 $V_{CE} = 300\text{V}$, $V_{DD} = 15\text{V}$
Dynamic test circuit in Figure A)

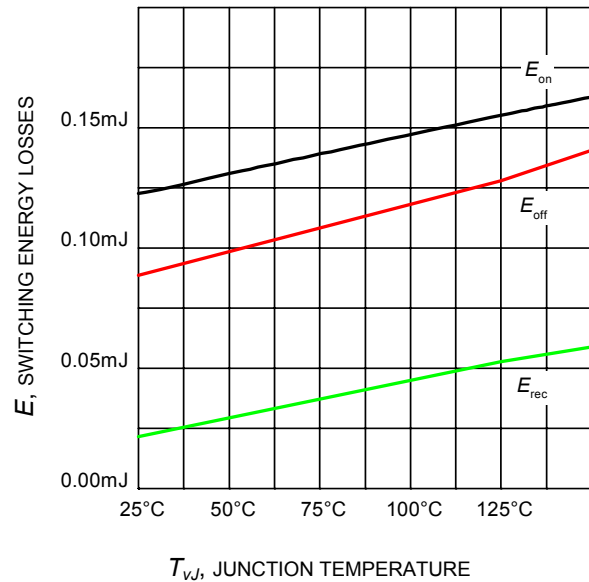

Figure 10. Typical switching energy losses as a function of junction temperature
(inductive load, $V_{CE} = 300\text{V}$,
 $V_{DD} = 15\text{V}$, $I_C = 6\text{A}$
Dynamic test circuit in Figure A)

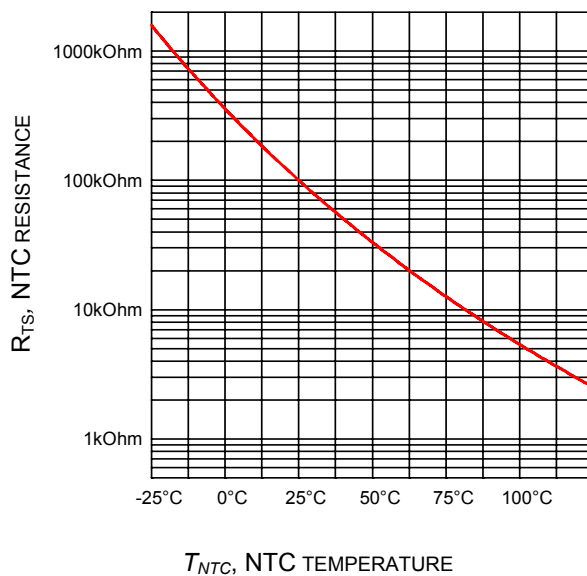

Figure 11. Typical Resistance of NTC as a function of NTC temperature

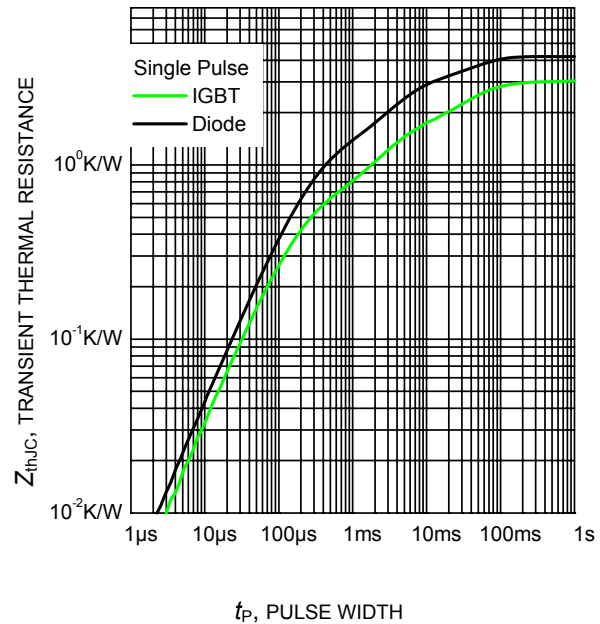

Figure 12. IGBT and Diode transient thermal impedance as a function of pulse width

Test Circuits and Parameter Definition

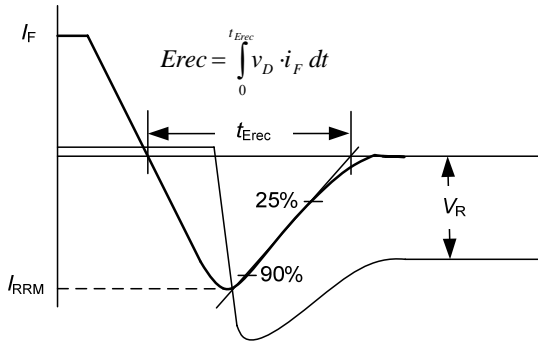
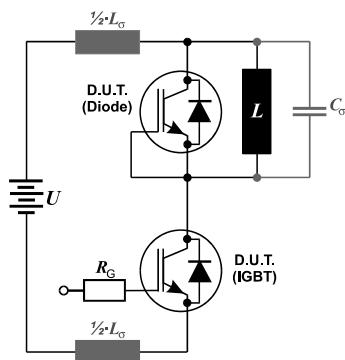

Figure B: Definition of diodes switching characteristics

Figure A: Dynamic test circuit

Leakage inductance $L_{\sigma} = 180\text{nH}$

Stray capacitance $C_{\sigma} = 39\text{pF}$

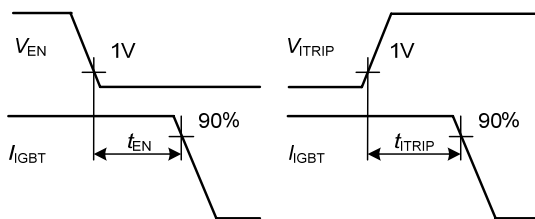

Figure C: Definition of Enable and ITIRP propagation delay

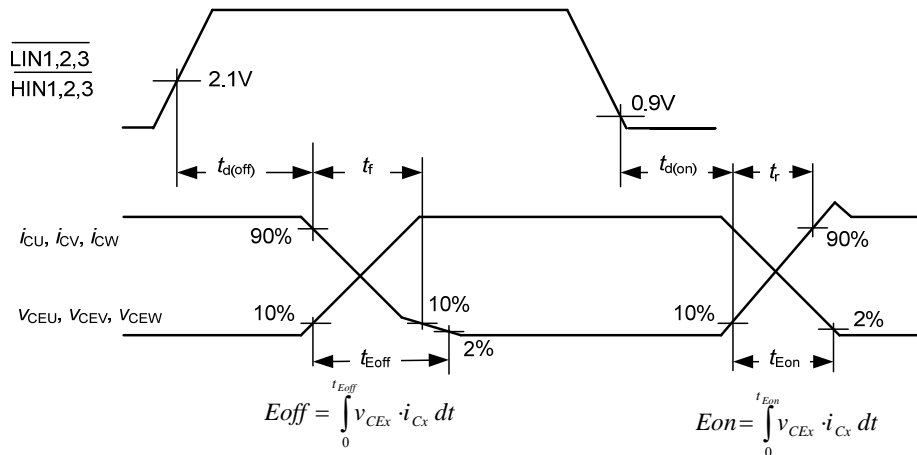

Figure D: Switching times definition and switching energy definition

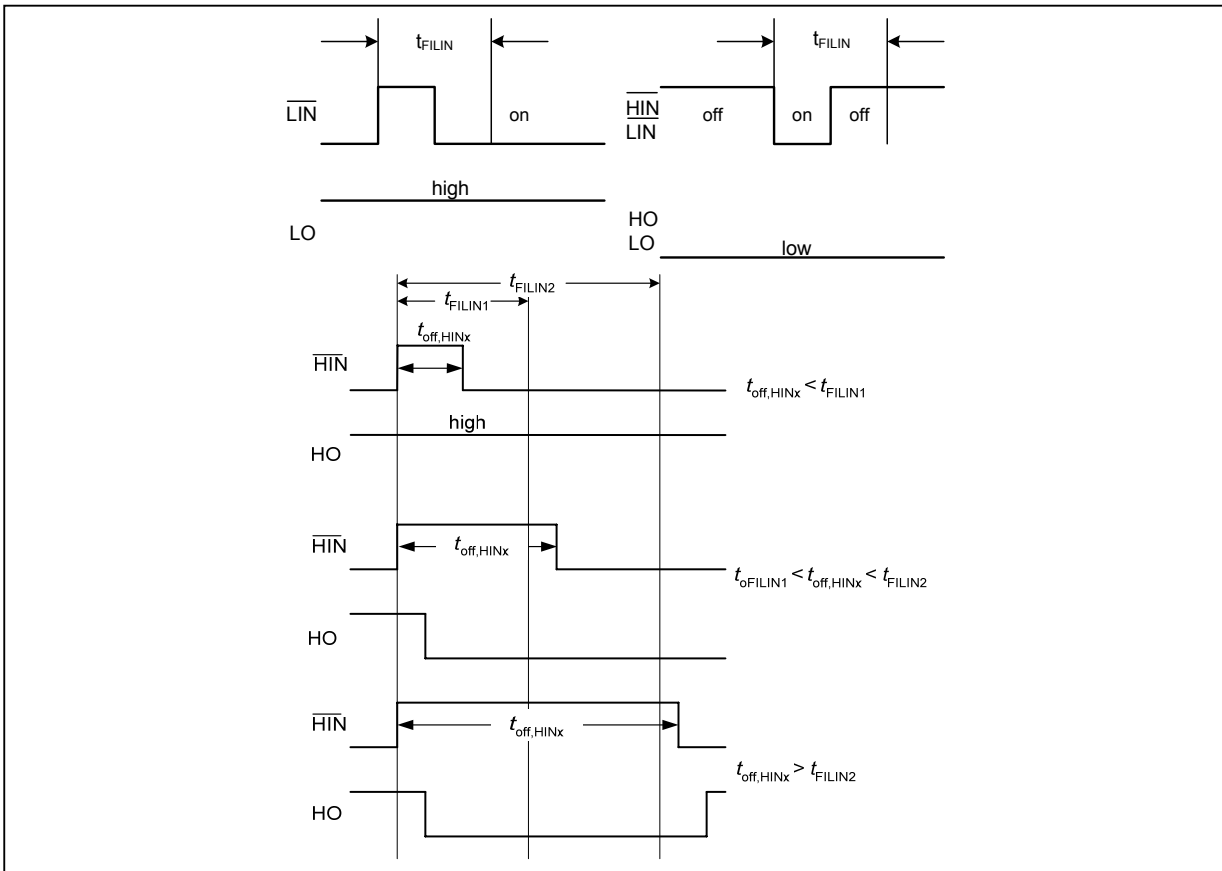
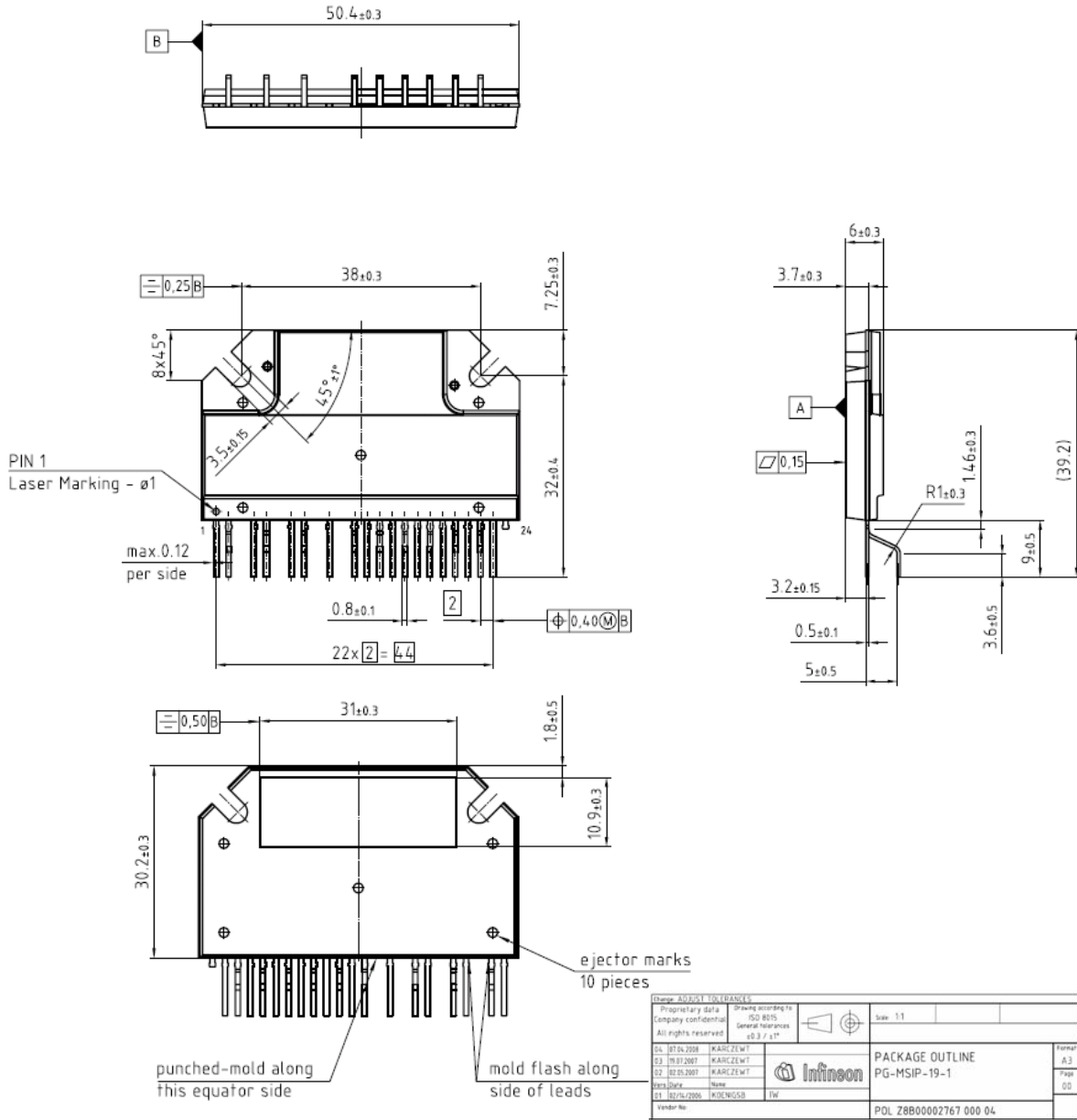

Figure E: Short Pulse suppression

Package Outline IKCS12G60DA



Description	Condition	Symbol	Value			Unit
			min	typ	max	
Weight		m_p	-	17	-	g

Note: There may occur discolourations on the copper surface without any effect of the thermal properties.

Package Outline IKCS12G60DC

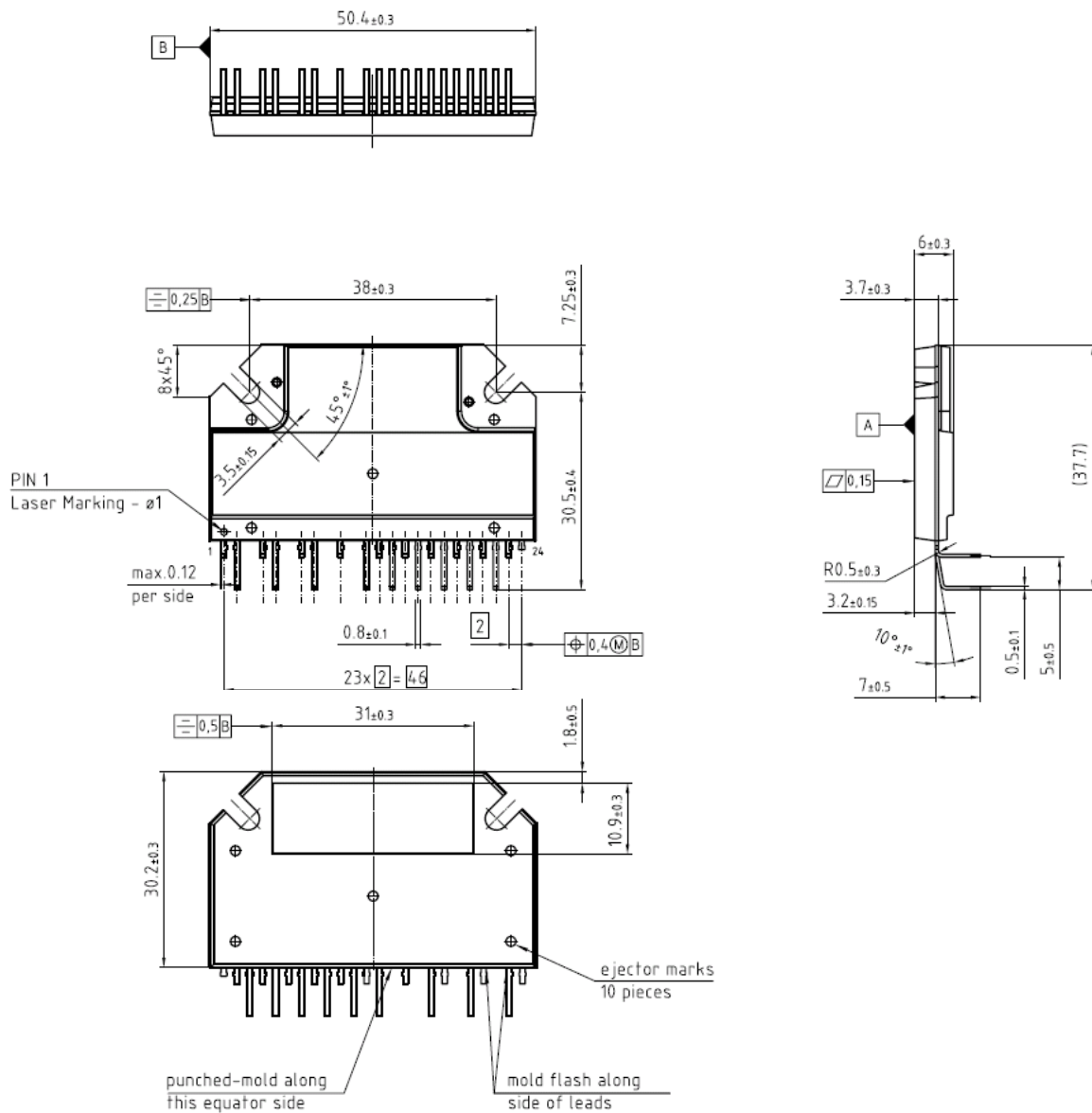

Change: ADJUST TOLERANCES		Drawing according to ISO 8015		Scale: 1:1	
Proprietary data		Company confidential		All rights reserved	
02 07.04.2008		KARCZEWT		Infineon	
01 28.08.2007		KARCZEWT		TW	
Vendor No:		POL Z8B00133956		000 02	
PACKAGE OUTLINE PG-MSIP-19-3					Format
					Page

Description	Condition	Symbol	Value			Unit
			min	typ	max	
Weight		m_P	-	17	-	g

Note: There may occur discolourations on the copper surface without any effect of the thermal properties.