

DATA SHEET

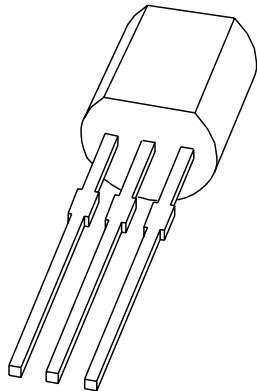

BB204B; BB204G

VHF variable capacitance double diodes

Product specification
Supersedes data of April 1992
File under Discrete Semiconductors, SC01

1996 May 03

VHF variable capacitance double diodes

BB204B; BB204G

FEATURES

- Selected capacitance ranges
- Leaded plastic package
- C30: 14 pF; ratio: 2.6.

APPLICATIONS

- Electronic tuning in FM radio applications
- VCO.

DESCRIPTION

The BB204B, BB204G are variable capacitance double diodes with common cathodes, fabricated in planar technology, and encapsulated in TO-92 variant leaded plastic packages.

PINNING

PIN	DESCRIPTION
1	anode (a1)
2	common cathode
3	anode (a2)

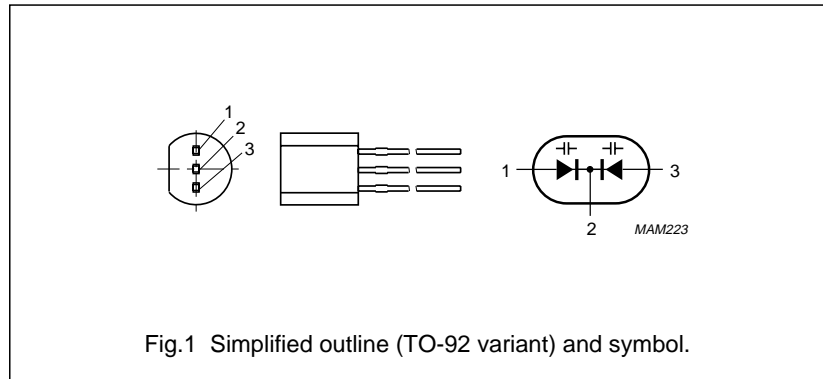

LIMITING VALUES

In accordance with the Absolute Maximum Rating System (IEC 134).

SYMBOL	PARAMETER	MIN.	MAX.	UNIT
Per diode				
V_R	continuous reverse voltage	–	30	V
I_F	continuous forward current	–	100	mA
T_{stg}	storage temperature	–55	+100	°C
T_j	operating junction temperature	–55	+100	°C

VHF variable capacitance double diodes

BB204B; BB204G

ELECTRICAL CHARACTERISTICST_j = 25 °C; unless otherwise specified.

SYMBOL	PARAMETER	CONDITIONS	MIN.	TYP.	MAX.	UNIT
Per diode						
I _R	reverse current	V _R = 30 V; see Fig.3	–	–	50	nA
		V _R = 30 V; T _j = 85 °C; see Fig.3	–	–	300	nA
r _s	diode series resistance	f = 100 MHz; note 1	–	0.2	0.4	Ω
C _d	diode capacitance BB204B	see Figs 2 and 4 V _R = 3 V; f = 1 MHz	37	–	42	pF
		V _R = 8 V; f = 1 MHz	24	–	29	pF
		V _R = 30 V; f = 1 MHz	–	14	–	pF
	BB204G	V _R = 3 V; f = 1 MHz	34	–	39	pF
		V _R = 8 V; f = 1 MHz	22	–	27	pF
		V _R = 30 V; f = 1 MHz	–	14	–	pF
$\frac{C_{d(3V)}}{C_{d(30V)}}$	capacitance ratio	f = 1 MHz	2.5	–	2.8	

Note

1. V_R is the value at which C_d = 38 pF.

VHF variable capacitance double diodes

BB204B; BB204G

GRAPHICAL DATA

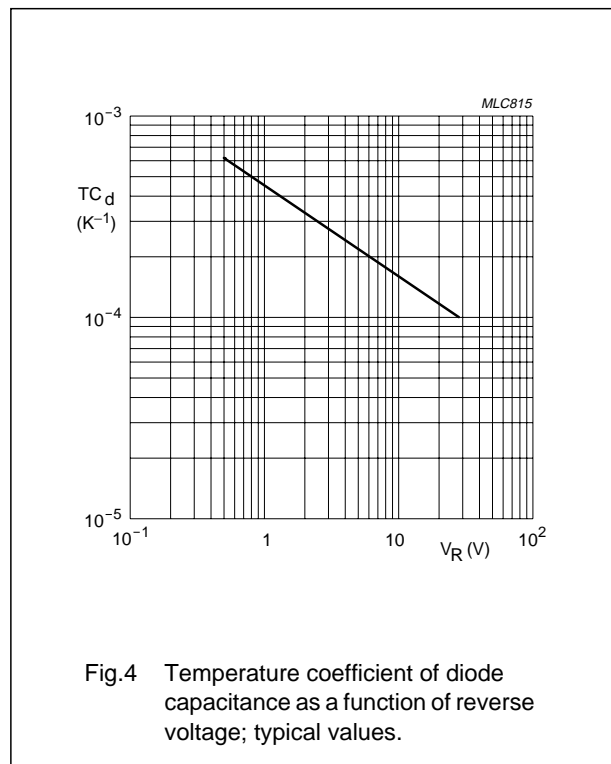
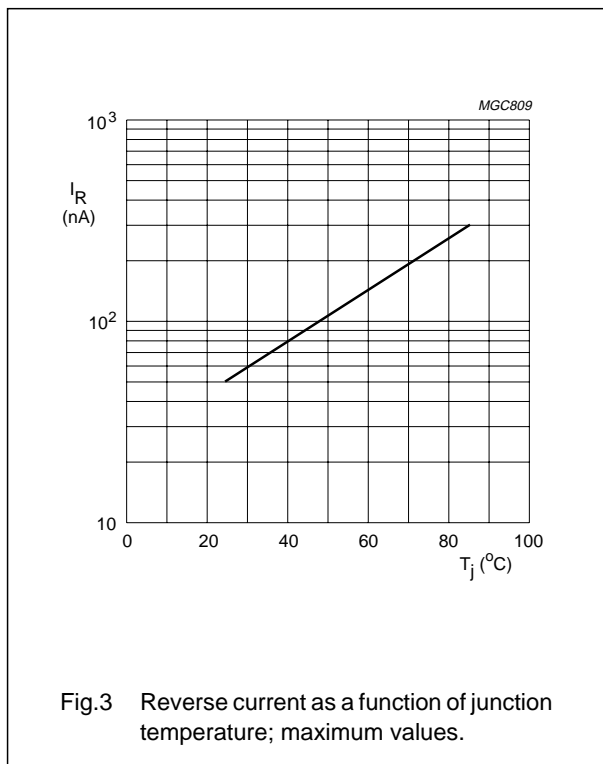
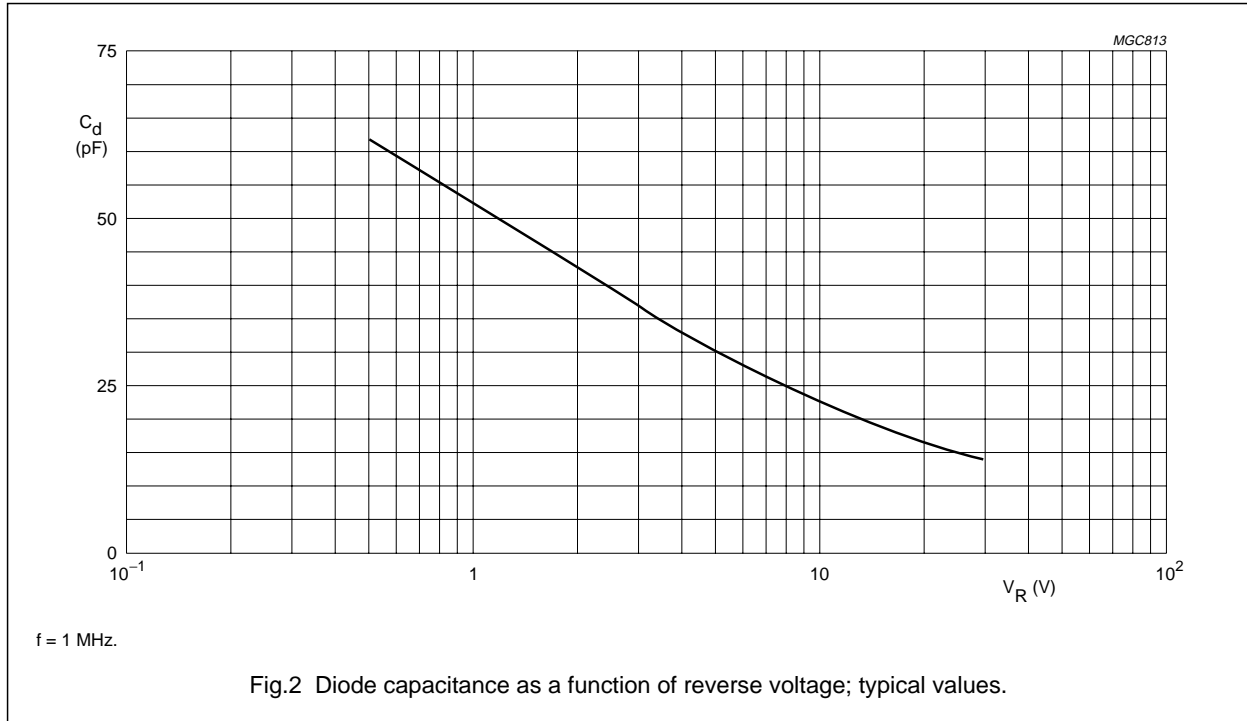

VHF variable capacitance double diodes

BB204B; BB204G

PACKAGE OUTLINE

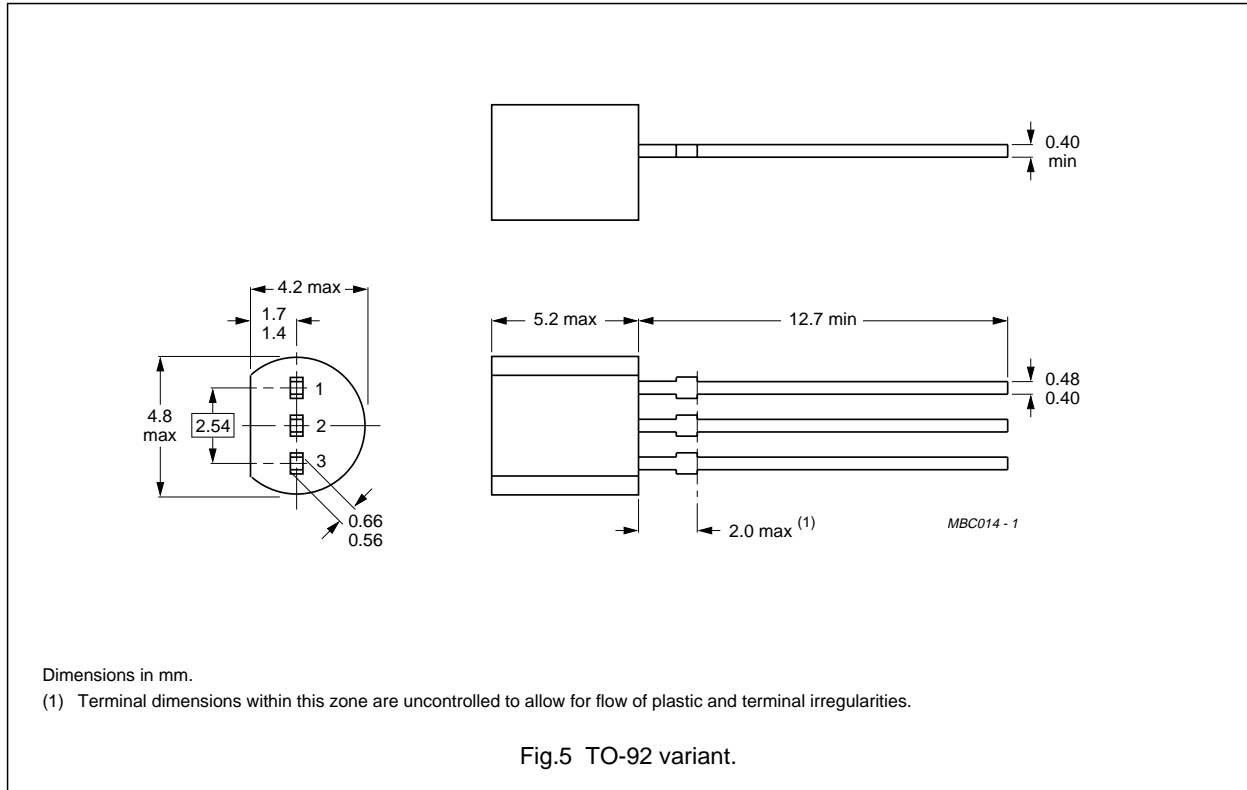

DEFINITIONS

Data sheet status	
Objective specification	This data sheet contains target or goal specifications for product development.
Preliminary specification	This data sheet contains preliminary data; supplementary data may be published later.
Product specification	This data sheet contains final product specifications.
Limiting values	
Limiting values given are in accordance with the Absolute Maximum Rating System (IEC 134). Stress above one or more of the limiting values may cause permanent damage to the device. These are stress ratings only and operation of the device at these or at any other conditions above those given in the Characteristics sections of the specification is not implied. Exposure to limiting values for extended periods may affect device reliability.	
Application information	
Where application information is given, it is advisory and does not form part of the specification.	

LIFE SUPPORT APPLICATIONS

These products are not designed for use in life support appliances, devices, or systems where malfunction of these products can reasonably be expected to result in personal injury. Philips customers using or selling these products for use in such applications do so at their own risk and agree to fully indemnify Philips for any damages resulting from such improper use or sale.