

RoHS Compliant Product
A suffix of "-C" specifies halogen & lead-free

DESCRIPTION

- Designed to protect voltage sensitive components from ESD
- Excellent clamping capability, low leakage and fast response
- Cellular phones, MP3 players, digital cameras ... etc.
- Suitable for electronics where board space is a major design consideration

FEATURES

- Response time is typically < 1 ns
- Low leakage
- Stand-off voltage: 3.3 V
- ESD rating of class 3 (> 15 kV) per human body model
- IEC61000-4-2 level 4 ESD protection

SOT-353

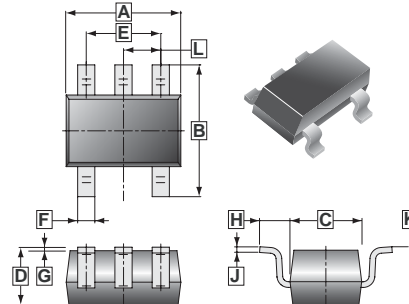

REF.	Millimeter		REF.	Millimeter	
	Min.	Max.		Min.	Max.
A	2.00	2.20	G	0.100	REF.
B	2.15	2.45	H	0.525	REF.
C	1.15	1.35	J	0.08	0.15
D	0.90	1.10	K	8°	
E	1.20	1.40	L	0.650 TYP.	
F	0.15	0.35			

MARKING CODE

33J4

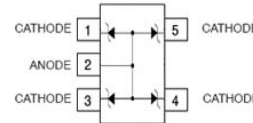

ABSOLUTE MAXIMUM RATINGS (T_A = 25°C unless otherwise specified)

Symbol	Parameter	Value	Units
V _{ESD}	IEC61000-4-2 (ESD)	air discharge	15
		contact discharge	8
P _D	Total Power Dissipation on FR-5 board (Note 2)	385	mW
T _L	Lead Solder Temperature - Max. (10 sec duration)	260	°C
R _{θJA}	Thermal Resistance Junction-to-ambient	325	°C / W
T _J , T _{STG}	Junction and Storage Temperature Range	-55 ~ +150	°C

Stresses exceeding "Maximum Ratings" may damage the device. "Maximum Ratings" are stress ratings only; functional operation above the recommended. Operating conditions is not implied. Extended exposure to stresses above the recommended operating conditions may affect device reliability.

1. FR-5 = 1.0 x 0.75 x 0.62 in.

2. Only 1 diode under power. For all 4 diodes under power, P_D will be 25%, mounted on FR-4 board with min pad.

ELECTRICAL CHARACTERISTICS (T = 25°C unless otherwise specified)

Type Number	Symbol	Min.	Typ.	Max.	Unit	Test Conditions
Reverse Stand-Off Voltage	V _{RWM}	-	-	3.3	V	
Reverse Leakage Current	I _R	-	-	250	nA	V _{RWM} = 3.3 V
Peak Pulse Current	I _{PP}	-	-	3.5	A	
Clamping Voltage 1	V _C	-	-	9.0	V	I _{PP} = 1 A
Clamping Voltage 2	V _C	-	-	12.0	V	I _{PP} = 3.5 A
Reverse Breakdown Voltage	V _{BR}	5.3	-	5.9	V	I _T = 1 mA, T _{AMB} = 25 °C
Test Current	I _T	-	1.0	-	mA	
Junction Capacitance	C	-	30	40	pF	
Peak Power Dissipation	P _{PK}	-	-	40	W	(@8x20 μS, @ T _A & = 25 °C; Non-repetitive current per Figure 1.)

RATINGS AND CHARACTERISTICS CURVES

Pulse Waveform

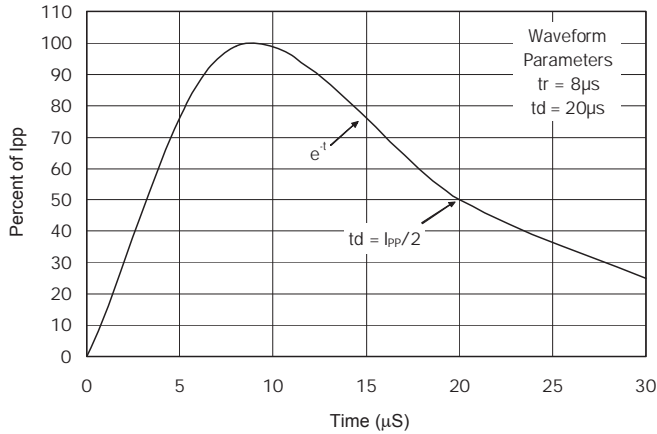

Clamping Voltage vs. Peak Pulse Current

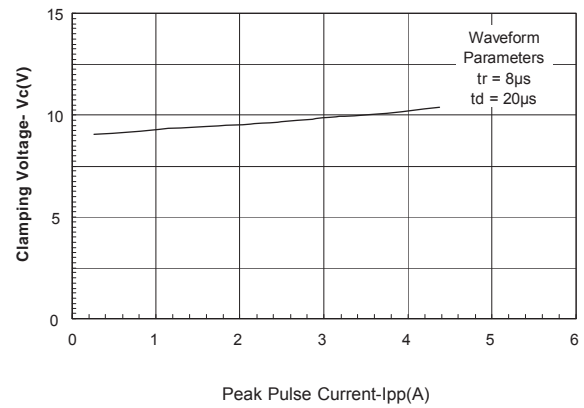

APPLICATION NOTE

The KS33J4 is designed for the uni-direction of up to four lines from the damage caused by Electronic Discharge (ESD) and surge pulses. The KS33J4 may be used on line where the signal polarities are above or below ground. KS33J4 can with stand and provides protection from a surge of 40 watts peak pulse power per line for a 8/20 µs waveform.

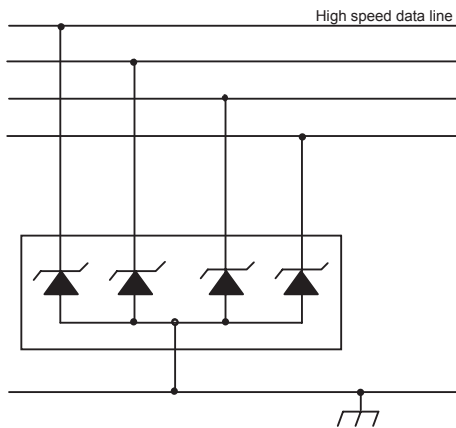

Typical application for uni-directional protection of four lines.