

Structure : Silicon Monolithic Integrated Circuit

Product : Audio Sound Processor for mini compo, micro compo, TV, radio cassette recorder

Type : **BD3491FS**

Package : SSOP – A32

●Feature

1. Low noise ($5\mu\text{Vrms}$ (TYP.)) and low distortion(0.002% (TYP.)).
2. Built-in simple surround. Furthermore, it can constitute good surround of sound image normal position with an external part.
3. It can constitute a bass boost or output gain with an external part.
4. When the volume setting exchanging, it can use a volume terminal as a microphone input terminal because there is not an impedance change of a volume terminal.
5. Bi-CMOS process is suitable for the design of low current and low energy. And it provides more quality for small scale regulator and heat in a set.
6. The package of this IC is SSOP-A32. It gathers a sound input terminals, sound output terminals respectively and it arranges them, to be arranging facilitates the laying-out of PCB pattern and reduces PCB area to one-way in the flow of the signal.

●Absolute Maximum Ratings (Ta=25°C)

Parameter	Symbol	Limits	Unit
Power supply Voltage	VCC	10.0	V
Input Voltage	V _{IN}	VCC+0.3~GND-0.3	V
Power Dissipation	Pd	950 *1	mW
Storage Temperature	Tastg	-55~+150	°C

*1 At Ta=25°C or higher, this value is decreased to 7.6mW/°C.

When Rohm standard board is mounted.

Rohm standard board: size: 70×70×1.6 (mm³)

material: FR4 glass-epoxy substrate (copper foil area: not more than 3%).

●Operating Range

Parameter	Symbol	Min.	Typ.	Max.	Unit
Power supply voltage	VCC	4.75	-	9.5	V
Temperature	Topr	-40	-	+85	°C

※ Design against radiation-proof isn't made.

Status of this document

The Japanese version of this document is the formal specification. A customer may use this translation only for a reference to help reading the formal version. If there are any differences in translation version of this document, formal version takes priority.

Application example

- ROHM cannot provide adequate confirmation of patents.
- The product described in this specification is designed to be used with ordinary electronic equipment or device (such as audio-visual equipment, office-automation equipment, communications devices, electrical appliances, and electronic toys.)
Should you intend to use this product with equipment or devices which require an extremely high level of reliability and the malfunction of which would directly endanger human life (such as medical instruments, transportation equipment, aerospace machinery, nuclear-reactor controllers, fuel controllers and other safety device), please be sure to consult with our sales representative in advance.
- ROHM assumes no responsibility for use of any circuits described herein, conveys no license under any patent or other right, and makes no representations that the circuits are free from patent infringement.

●Function

Function	Specifications
Input selector	Stereo 6 input + MUTE + Input short
Input gain	0~8dB (2dB step), 12, 16, 20dB
Volume	0dB~-87dB (1dB step), -∞dB Possible to control independently
Bass	Gain=-14~+14dB (2dB step)
Treble	Gain=-14~+14dB (2dB step)
Surround	Gain=OFF, Low, Middle, High

●Electrical characteristics

(Unless specified particularly, Ta=25°C, VCC=9V, f=1kHz, Vin=1Vrms, Rg=600Ω, RL=10kΩ, A input, Input gain 0dB, Volume 0dB, Bass 0dB, Treble 0dB, Surround=OFF)

Item	Symbol	Limit			Unit	Condition
		Min.	Typ.	Max.		
Current upon no signal	Iq	—	7	15	mA	No signal
Voltage gain	Gv	-1.5	0	1.5	dB	$Gv=20\log(VOUT/VIN)$
Channel balance	CB	-1.5	0	1.5	dB	$CB=Gv1-Gv2$
Total harmonic distortion	THD+N	—	0.002	0.1	%	VOUT=1Vrms BW=400-30kHz
Output noise voltage	VNO	—	5	20	μVrms	Rg=0Ω BW=IHF-A
Residual output noise voltage	VNOR	—	5	20	μVrms	Fader=-∞dB Rg=0Ω BW=IHF-A
Cross-talk between channels	CTC	—	-100	-80	dB	Rg=0Ω $CTC=20\log(VOUT/VIN)$ BW=IHF-A
Input impedance	RIN	35	50	65	kΩ	
Maximum input voltage	VIM	2.1	2.4	—	Vrms	VIM at THD+N(VOUT)=1% BW=400-30KHz
Cross-talk between selectors	CTS	—	-100	-80	dB	Rg=0Ω $CTS=20\log(VOUT/VOUT)$ BW=IHF-A
Control range	Gv MAX	-90	-87	-84	dB	VIN=2Vrms $Gv=20\log(VOUT/VIN)$
Maximum attenuation	Gv MIN	—	-100	-80	dB	Volume=-∞dB $Gv=20\log(VOUT/VIN)$
Bass maximum boost gain	Gb BST	11.5	14	16.5	dB	Gain=14dB, f=100Hz VIN=100mVrms GB=20log(VOUT/VIN)
Bass maximum cut gain	Gb CUT	-16.5	-14	-11.5	dB	Gain=-14dB, f=100Hz VIN=2Vrms GB=20log(VOUT/VIN)
Treble maximum boost gain	Gt BST	11.5	14	16.5	dB	Gain=+14dB, f=10KHz VIN=100mVrms GT=20log(VOUT/VIN)
Treble maximum cut gain	Gt CUT	-16.5	-14	-11.5	dB	Gain=-14dB, f=10KHz VIN=2Vrms GT=20log(VOUT/VIN)

● Dimensional outline drawing

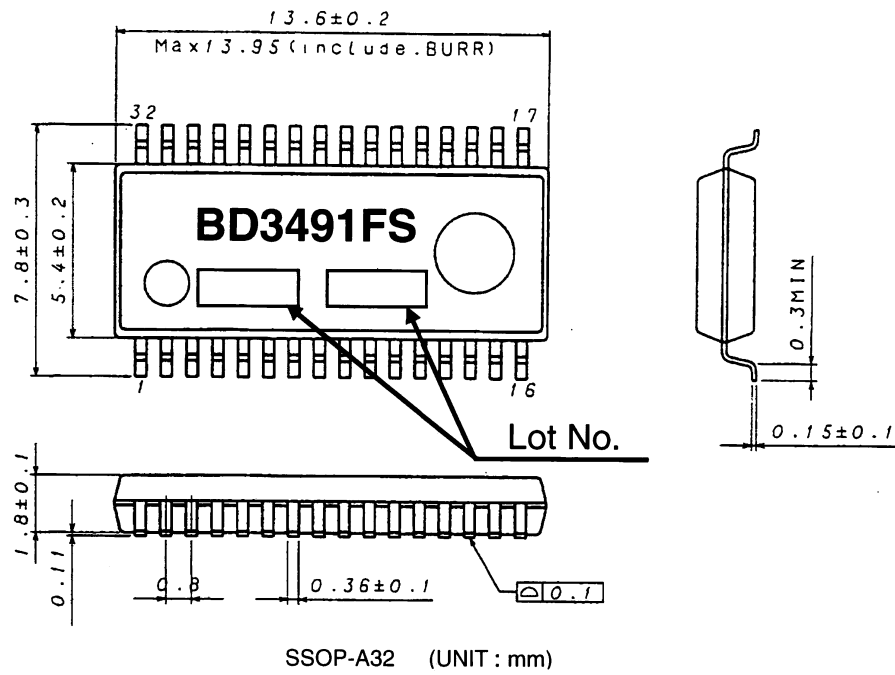

● Block diagram

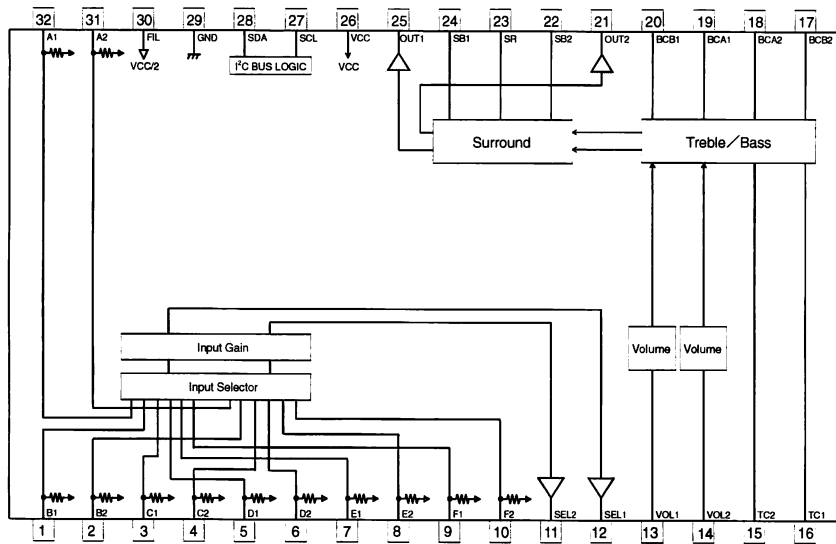

● Terminal No. / Terminal Name

Terminal No.	Terminal Name
1	B1
2	B2
3	C1
4	C2
5	D1
6	D2
7	E1
8	E2
9	F1
10	F2
11	SEL2
12	SEL1
13	VOL1
14	VOL2
15	TC2
16	TC1
17	BCB2
18	BCA2
19	BCA1
20	BCB1
21	OUT2
22	SB2
23	SR
24	SB1
25	OUT1
26	VCC
27	SCL
28	SDA
29	GND
30	FIL
31	A2
32	A1

●Cautions on use

(1) Absolute maximum ratings

If applied voltage, operating temperature range, or other absolute maximum ratings are exceeded, the LSI may be damaged. Do not apply voltages or temperatures that exceed the absolute maximum ratings. If you think of a case in which absolute maximum ratings are exceeded, enforce fuses or other physical safety measures and investigate how not to apply the conditions under which absolute maximum ratings are exceeded to the LSI.

(2) GND potential

Make the GND pin voltage such that it is the lowest voltage even when operating below it. Actually confirm that the voltage of each pin does not become a lower voltage than the GND pin, including transient phenomena.

(3) Thermal design

Perform thermal design in which there are adequate margins by taking into account the allowable power dissipation in actual states of use.

(4) Shorts between pins and misinstallation

When mounting the LSI on a board, pay adequate attention to orientation and placement discrepancies of the LSI. If it is misinstalled and the power is turned on, the LSI may be damaged. It also may be damaged if it is shorted by a foreign substance coming between pins of the LSI or between a pin and a power supply or a pin and a GND.

(5) Operation in strong magnetic fields

Adequately evaluate use in a strong magnetic field, since there is a possibility of malfunction.

Notes

- No technical content pages of this document may be reproduced in any form or transmitted by any means without prior permission of ROHM CO.,LTD.
- The contents described herein are subject to change without notice. The specifications for the product described in this document are for reference only. Upon actual use, therefore, please request that specifications to be separately delivered.
- Application circuit diagrams and circuit constants contained herein are shown as examples of standard use and operation. Please pay careful attention to the peripheral conditions when designing circuits and deciding upon circuit constants in the set.
- Any data, including, but not limited to application circuit diagrams information, described herein are intended only as illustrations of such devices and not as the specifications for such devices. ROHM CO.,LTD. disclaims any warranty that any use of such devices shall be free from infringement of any third party's intellectual property rights or other proprietary rights, and further, assumes no liability of whatsoever nature in the event of any such infringement, or arising from or connected with or related to the use of such devices.
- Upon the sale of any such devices, other than for buyer's right to use such devices itself, resell or otherwise dispose of the same, no express or implied right or license to practice or commercially exploit any intellectual property rights or other proprietary rights owned or controlled by
- ROHM CO., LTD. is granted to any such buyer.
- Products listed in this document are no antiradiation design.

The products listed in this document are designed to be used with ordinary electronic equipment or devices (such as audio visual equipment, office-automation equipment, communications devices, electrical appliances and electronic toys).

Should you intend to use these products with equipment or devices which require an extremely high level of reliability and the malfunction of which would directly endanger human life (such as medical instruments, transportation equipment, aerospace machinery, nuclear-reactor controllers, fuel controllers and other safety devices), please be sure to consult with our sales representative in advance.

It is our top priority to supply products with the utmost quality and reliability. However, there is always a chance of failure due to unexpected factors. Therefore, please take into account the derating characteristics and allow for sufficient safety features, such as extra margin, anti-flammability, and fail-safe measures when designing in order to prevent possible accidents that may result in bodily harm or fire caused by component failure. ROHM cannot be held responsible for any damages arising from the use of the products under conditions out of the range of the specifications or due to non-compliance with the NOTES specified in this catalog.

Thank you for your accessing to ROHM product informations.

More detail product informations and catalogs are available, please contact your nearest sales office.

ROHM Customer Support System

THE AMERICAS / EUROPE / ASIA / JAPAN

www.rohm.com

Contact us : webmaster@rohm.co.jp