

Structure Silicon monolithic Integrated circuit
Product Clock Generator With Built-in VCXO
Type **BU3058FV**
Feature To generate clocks for the Digital-TV.
 Clock signals are generated by connecting crystal oscillator.
 Built-in VCXO has the variable width of $\text{Typ} \pm 105 \text{ppm}$.

○ **Absolute Maximum Ratings (Ta=25°C)**

Parameter	Symbol	Ratings	Unit
Supply voltage	VDD	-0.3 ~ 4.0	V
Input Voltage	VIN	-0.3~VDD+0.3	V
Storage Temperature range	Tstg	-55~125	°C
Power dissipation	PD	450 ^{※1}	mW

^{※1} A measure value at mounting on 70x70x1.6mm glass epoxy substrate.
 In the case of exceeding Ta=25°C, 4.5mW should be reduced per 1°C.

[※] The radiation-resistance design is not carried out.

[※] Operation is not guaranteed.

○ **Operating Conditions**

Parameter	Symbol	Ratings	Unit
Supply voltage	VDD	3.135 ~ 3.465	V
Input "H" Voltage	VIH	0.8VDD ~ VDD	V
Input "L" Voltage	VIL	0.0 ~ 0.2VDD	V
Operating Temperature	topr	-10 ~ 75	°C
Frequency Control Voltage	Vc	0.0 ~ VDD	V

○Electrical Characteristics

(VDD=3.3V, Ta=25°C, Crystal Frequency=27.000000MHz, at No Load, unless otherwise specified)

Parameter	Symbol	Limit			Unit	Conditions
		Min.	Typ.	Max.		
Output H voltage	VOH	VDD-0.4	—	—	V	IOH=4.0mA
Output L voltage	VOL	—	—	0.4	V	IOL=4.0mA
Operating circuit current	IDD	—	40.0	52.0	mA	Output No Load
Input H current 1	IupH	-1.5	—	1.5	μA	PDB Terminal, VIH=VDD
Input H current 2	IdnH	19.0	69.0	136.5	μA	TEST Terminal, VIH=VDD
Input H current 3	IdirH	-1.5	—	1.5	μA	VCTRL, SEL1, SEL2 Terminal, VIH=VDD
Input L current 1	IupL	-126.0	-53.0	-17.0	μA	PDB Terminal, VIL=0.0V
Input L current 2	IdnL	-1.5	—	1.5	μA	TEST Terminal, VIL=0.0V
Input L current 3	IdirL	-1.5	—	1.5	μA	VCTRL, SEL1, SEL2 Terminal, VIL=0.0V
Crystal Pullability	fp	±80	±105	±130	ppm	0 ≤ VCTRL ≤ VDD *

* This is a guarantee with only IC.
The arrangement with a crystal maker is required separately about crystal variation.

○Block diagram

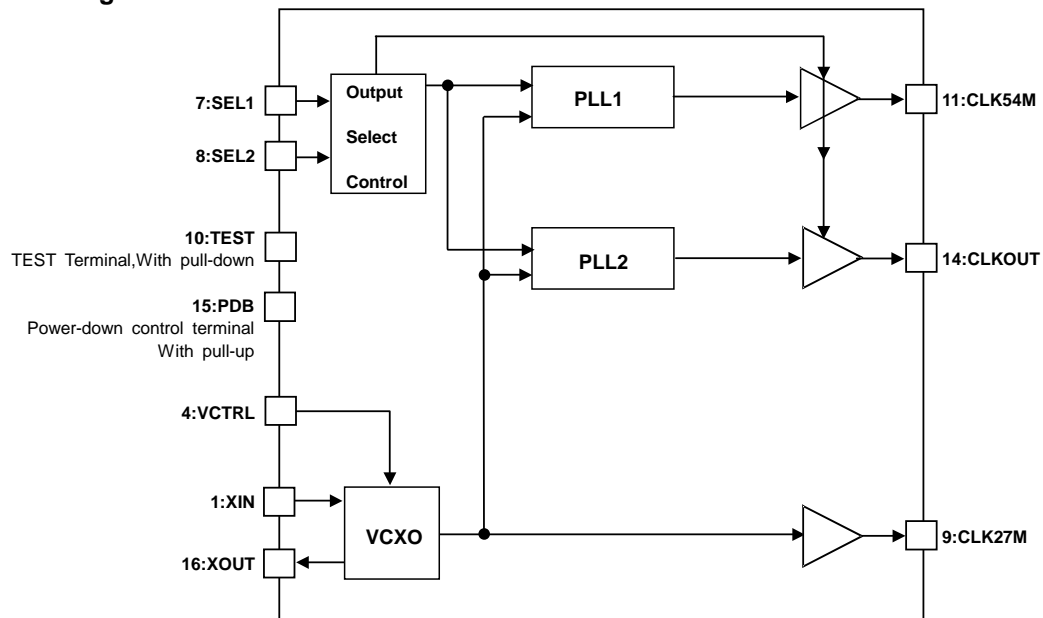

○Table of Output Frequency (Crystal Frequency=27.000000MHz)

mode No.	SEL1	SEL2	14pin	11pin	9pin
			CLKOUT	CLK54M	CLK27M
①	L	L	66.000000MHz	54.000000MHz	27.000000MHz
②	L	H	74.250000MHz	54.000000MHz	27.000000MHz
③	H	L	77.000000MHz	54.000000MHz	27.000000MHz
④	H	H	82.000000MHz	54.000000MHz	27.000000MHz

○ Package Outline, Appearance of Marker

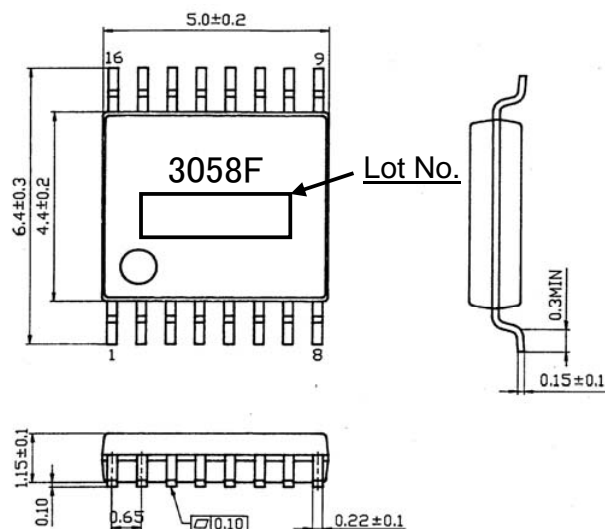

SSOP-B16

(UNIT : mm)

○ Pin Function

PIN No.	PIN Name	Function
1	XIN	Crystal Input terminal
2	AVDD1	Power supply for VCXO
3	AVSS1	GND for VCXO
4	VCTRL	VCXO control input terminal
5	AVDD2	Power supply for PLL-Analog
6	AVSS2	GND for PLL-Analog
7	SEL1	CLKOUT output control terminal1
8	SEL2	CLKOUT output control terminal2
9	CLK27M	27.000000MHz Output
10	TEST	Test terminal with pull-down
11	CLK54M	54.000000MHz Output
12	VSS	GND for PLL-Digital
13	VDD	Power supply for PLL-Digital
14	CLKOUT	66.000000MHz / 74.250000MHz / 77.000000MHz / 82.000000MHz Output
15	PDB	Power-down control terminal,with pull-up
16	XOUT	Crystal Output terminal

● Cautions on use (BU3058FV)

Basically, mount ICs to the printed circuit board for use. (If the ICs are not mounted to the printed circuit board, the characteristics of ICs may not be fully demonstrated.)

Mount 0.1μF capacitors in the vicinity of the IC PINs between 2PIN (AVDD1), 3PIN (AVSS1), and 5PIN(AVDD2), 6PIN(AVSS2), and 12PIN (VSS), 13PIN (VDD) respectively.

To obtain accurate frequency, capacitance (pF) need to be placed between 3PIN (AVSS1) and 1PIN (XIN), 3PIN (AVSS1) and 16PIN(XOUT).

Depending on the conditions of the printed circuit board, mount an additional electrolytic capacitor between the power supply and GND terminal.

For EMI protection, it is effective to put ferrite beads in the origin of power supply to be fed to BU3058FV from the printed circuit board or to insert a capacitor (of 1Ω or less), which bypasses high frequency desired, between the power supply and the GND terminal.

For ICs with more than one power supply, it is possible that rush current may flow instantaneously due to the internal powering sequence and delays. Therefore, give special consideration to power coupling capacitance, power wiring, width of GND wiring, and routing of wiring.

●Cautions on use (common)

(1) Absolute Maximum Ratings

An excess in the absolute maximum ratings, such as supply voltage, temperature range of operating conditions, etc., can break down devices, thus making impossible to identify breaking mode such as a short circuit or an open circuit. If any special mode exceeding the absolute maximum ratings is assumed, consideration should be given to take physical safety measures including the use of fuses, etc.

(2) Operating conditions

These conditions represent a range within which characteristics can be provided approximately as expected. The electrical characteristics are guaranteed under the conditions of each parameter.

(3) Reverse connection of power supply connector

The reverse connection of power supply connector can break down ICs. Take protective measures against the breakdown due to the reverse connection, such as mounting an external diode between the power supply and the IC's power supply terminal.

(4) Power supply line

Design PCB pattern to provide low impedance for the wiring between the power supply and the GND lines. In this regard, for the digital block power supply and the analog block power supply, even though these power supplies has the same level of potential, separate the power supply pattern for the digital block from that for the analog block, thus suppressing the diffraction of digital noises to the analog block power supply resulting from impedance common to the wiring patterns. For the GND line, give consideration to design the patterns in a similar manner.

Furthermore, for all power supply terminals to ICs, mount a capacitor between the power supply and the GND terminal. At the same time, in order to use an electrolytic capacitor, thoroughly check to be sure the characteristics of the capacitor to be used present no problem including the occurrence of capacity dropout at a low temperature, thus determining the constant.

(5) GND voltage

Make setting of the potential of the GND terminal so that it will be maintained at the minimum in any operating state. Furthermore, check to be sure no terminals are at a potential lower than the GND voltage including an actual electric transient.

(6) Short circuit between terminals and erroneous mounting

In order to mount ICs on a set PCB, pay thorough attention to the direction and offset of the ICs. Erroneous mounting can break down the ICs. Furthermore, if a short circuit occurs due to foreign matters entering between terminals or between the terminal and the power supply or the GND terminal, the ICs can break down.

(7) Operation in strong electromagnetic field

Be noted that using ICs in the strong electromagnetic field can malfunction them.

(8) Inspection with set PCB

On the inspection with the set PCB, if a capacitor is connected to a low-impedance IC terminal, the IC can suffer stress. Therefore, be sure to discharge from the set PCB by each process. Furthermore, in order to mount or dismount the set PCB to/from the jig for the inspection process, be sure to turn OFF the power supply and then mount the set PCB to the jig. After the completion of the inspection, be sure to turn OFF the power supply and then dismount it from the jig. In addition, for protection against static electricity, establish a ground for the assembly process and pay thorough attention to the transportation and the storage of the set PCB.

(9) Input terminals

In terms of the construction of IC, parasitic elements are inevitably formed in relation to potential. The operation of the parasitic element can cause interference with circuit operation, thus resulting in a malfunction and then breakdown of the input terminal. Therefore, pay thorough attention not to handle the input terminals, such as to apply to the input terminals a voltage lower than the GND respectively, so that any parasitic element will operate. Furthermore, do not apply a voltage to the input terminals when no power supply voltage is applied to the IC. In addition, even if the power supply voltage is applied, apply to the input terminals a voltage lower than the power supply voltage or within the guaranteed value of electrical characteristics.

(1 0) Ground wiring pattern

If small-signal GND and large-current GND are provided, It will be recommended to separate the large-current GND pattern from the small-signal GND pattern and establish a single ground at the reference point of the set PCB so that resistance to the wiring pattern and voltage fluctuations due to a large current will cause no fluctuations in voltages of the small-signal GND. Pay attention not to cause fluctuations in the GND wiring pattern of external parts as well.

(1 1) External capacitor

In order to use a ceramic capacitor as the external capacitor, determine the constant with consideration given to a degradation in the nominal capacitance due to DC bias and changes in the capacitance due to temperature, etc.

Notes

No copying or reproduction of this document, in part or in whole, is permitted without the consent of ROHM Co.,Ltd.

The content specified herein is subject to change for improvement without notice.

The content specified herein is for the purpose of introducing ROHM's products (hereinafter "Products"). If you wish to use any such Product, please be sure to refer to the specifications, which can be obtained from ROHM upon request.

Examples of application circuits, circuit constants and any other information contained herein illustrate the standard usage and operations of the Products. The peripheral conditions must be taken into account when designing circuits for mass production.

Great care was taken in ensuring the accuracy of the information specified in this document. However, should you incur any damage arising from any inaccuracy or misprint of such information, ROHM shall bear no responsibility for such damage.

The technical information specified herein is intended only to show the typical functions of and examples of application circuits for the Products. ROHM does not grant you, explicitly or implicitly, any license to use or exercise intellectual property or other rights held by ROHM and other parties. ROHM shall bear no responsibility whatsoever for any dispute arising from the use of such technical information.

The Products specified in this document are intended to be used with general-use electronic equipment or devices (such as audio visual equipment, office-automation equipment, communication devices, electronic appliances and amusement devices).

The Products specified in this document are not designed to be radiation tolerant.

While ROHM always makes efforts to enhance the quality and reliability of its Products, a Product may fail or malfunction for a variety of reasons.

Please be sure to implement in your equipment using the Products safety measures to guard against the possibility of physical injury, fire or any other damage caused in the event of the failure of any Product, such as derating, redundancy, fire control and fail-safe designs. ROHM shall bear no responsibility whatsoever for your use of any Product outside of the prescribed scope or not in accordance with the instruction manual.

The Products are not designed or manufactured to be used with any equipment, device or system which requires an extremely high level of reliability the failure or malfunction of which may result in a direct threat to human life or create a risk of human injury (such as a medical instrument, transportation equipment, aerospace machinery, nuclear-reactor controller, fuel-controller or other safety device). ROHM shall bear no responsibility in any way for use of any of the Products for the above special purposes. If a Product is intended to be used for any such special purpose, please contact a ROHM sales representative before purchasing.

If you intend to export or ship overseas any Product or technology specified herein that may be controlled under the Foreign Exchange and the Foreign Trade Law, you will be required to obtain a license or permit under the Law.



Thank you for your accessing to ROHM product informations.
More detail product informations and catalogs are available, please contact us.

ROHM Customer Support System

<http://www.rohm.com/contact/>