

Silicon Diffused Power Transistor

BUJ403BX

GENERAL DESCRIPTION

High-voltage, high-speed planar-passivated npn power switching transistor in a plastic full-pack envelope intended for use in high frequency electronic lighting ballast applications, converters, inverters, switching regulators, motor control systems, etc.

QUICK REFERENCE DATA

SYMBOL	PARAMETER	CONDITIONS	TYP.	MAX.	UNIT
V_{CESM}	Collector-emitter voltage peak value	$V_{BE} = 0\text{ V}$	-	1200	V
V_{CBO}	Collector-base voltage (open emitter)		-	1200	V
V_{CEO}	Collector-emitter voltage (open base)		-	525	V
V_{EBO}	Emitter-base voltage (open collector)		18	-	V
I_C	Collector current (DC)		-	6	A
I_{CM}	Collector current peak value		-	10	A
P_{tot}	Total power dissipation	$T_{hs} \leq 25\text{ }^\circ\text{C}$	-	32	W
V_{CEsat}	Collector-emitter saturation voltage	$I_C = 2\text{ A}; I_B = 0.4\text{ A}$	0.14	1.0	V
h_{FEsat}	DC current gain	$I_C = 2\text{ A}; V_{CE} = 5\text{ V}$	21	25	
t_{fi}	Fall time	$I_C = 2.5\text{ A}; I_{B1} = 0.5\text{ A}$	140	203	ns

PINNING - SOT186A

PIN	DESCRIPTION
1	base
2	collector
3	emitter
case	isolated

PIN CONFIGURATION

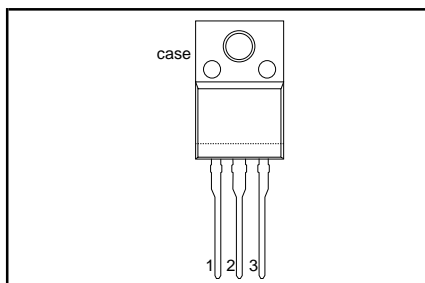

SYMBOL

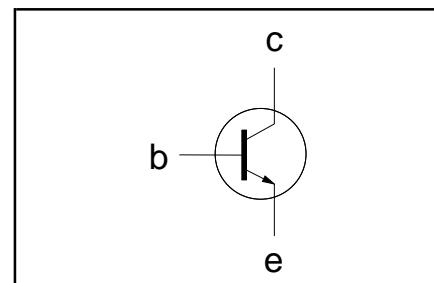

LIMITING VALUES

Limiting values in accordance with the Absolute Maximum Rating System (IEC 134)

SYMBOL	PARAMETER	CONDITIONS	MIN.	MAX.	UNIT
V_{CESM}	Collector to emitter voltage	$V_{BE} = 0\text{ V}$	-	1200	V
V_{CEO}	Collector to emitter voltage (open base)		-	525	V
V_{CBO}	Collector to base voltage (open emitter)		-	1200	V
V_{EBO}	Emitter-base voltage (open collector)		16	-	V
I_C	Collector current (DC)		-	6	A
I_{CM}	Collector current peak value		-	10	A
I_B	Base current (DC)		-	3	A
I_{BM}	Base current peak value		-	5	A
P_{tot}	Total power dissipation	$T_{hs} \leq 25\text{ }^\circ\text{C}$	-	32	W
T_{stg}	Storage temperature		-65	150	$^\circ\text{C}$
T_j	Junction temperature		-	150	$^\circ\text{C}$

Silicon Diffused Power Transistor

BUJ403BX

AVALANCHE ENERGY CAPABILITY

SYMBOL	PARAMETER	CONDITIONS	TYP.	MAX.	UNIT
EAS	Avalanche Energy Capability ¹	$V_{CC} = 150V; V_{BB} = -5V; L_C = 15mH; L_B = 1\mu H$ $T_{hs} \leq 110\text{ }^\circ\text{C}$	-	1.0	mJ

THERMAL RESISTANCES

SYMBOL	PARAMETER	CONDITIONS	TYP.	MAX.	UNIT
$R_{th\ j-hs}$	Junction to heatsink	with heatsink compound	-	3.95	K/W
$R_{th\ j-a}$	Junction to ambient	in free air	55	-	K/W

STATIC CHARACTERISTICS

 $T_{hs} = 25\text{ }^\circ\text{C}$ unless otherwise specified

SYMBOL	PARAMETER	CONDITIONS	MIN.	TYP.	MAX.	UNIT
$I_{CES}; I_{CBO}$ I_{CES}	Collector cut-off current ²	$V_{BE} = 0\text{ V}; V_{CE} = V_{CESMmax}$ $V_{BE} = 0\text{ V}; V_{CE} = V_{CESMmax}$ $T_j = 125\text{ }^\circ\text{C}$	-	-	0.2 0.5	mA mA
I_{CEO} I_{EBO} $V_{CEOsust}$	Collector cut-off current ² Emitter cut-off current Collector-emitter sustaining voltage	$V_{CEO} = V_{CEOMmax} (550V)$ $V_{EB} = 9\text{ V}; I_C = 0\text{ A}$ $I_B = 0\text{ A}; I_C = 10\text{ mA};$ $L = 25\text{ mH}$	- - 525	- - -	0.1 1.0 -	mA mA V
V_{CEsat} V_{BEsat}	Collector-emitter saturation voltage Base-emitter saturation voltage	$I_C = 2.0\text{ A}; I_B = 0.4\text{ A}$ $I_C = 2.0\text{ A}; I_B = 0.4\text{ A}$	- -	0.14 0.89	1.0 1.5	V V
h_{FE} h_{FE} h_{FEsat}	DC current gain DC current gain DC current gain	$I_C = 1\text{ mA}; V_{CE} = 5\text{ V}$ $I_C = 500\text{ mA}; V_{CE} = 5\text{ V}$ $I_C = 2.0\text{ A}; V_{CE} = 5\text{ V}$	19 30 17	28 45 21	- 65 25	- - -

DYNAMIC CHARACTERISTICS

 $T_{hs} = 25\text{ }^\circ\text{C}$ unless otherwise specified

SYMBOL	PARAMETER	CONDITIONS	TYP.	MAX.	UNIT
t_{on} t_s t_f	Switching times (resistive load) Turn-on time Turn-off storage time Turn-off fall time	$I_{Con} = 2.5\text{ A}; I_{Bon} = -I_{Boff} = 0.5\text{ A};$ $R_L = 75\text{ ohms}; V_{BB2} = 4\text{ V};$	0.6 4.5 0.4	0.95 6.4 0.59	μs μs μs
t_{si} t_{fi}	Switching times (inductive load) Turn-off storage time Turn-off fall time	$I_{Con} = 2.5\text{ A}; I_{Bon} = 0.5\text{ A}; L_B = 1\text{ }\mu\text{H};$ $-V_{BB} = 5\text{ V}$	1.67 140	2.3 203	μs ns
t_{si} t_{fi}	Switching times (inductive load) Turn-off storage time Turn-off fall time	$I_{Con} = 2.5\text{ A}; I_{Bon} = 0.5\text{ A}; L_B = 1\text{ }\mu\text{H};$ $-V_{BB} = 5\text{ V}; T_j = 100\text{ }^\circ\text{C}$	1.9 144	2.7 216	μs ns

1 Fig. 14 without clamping voltage (VCL). Probe point is used to measure the BVCE at avalanche.

2 Measured with half sine-wave voltage (curve tracer).

Silicon Diffused Power Transistor

BUJ403BX

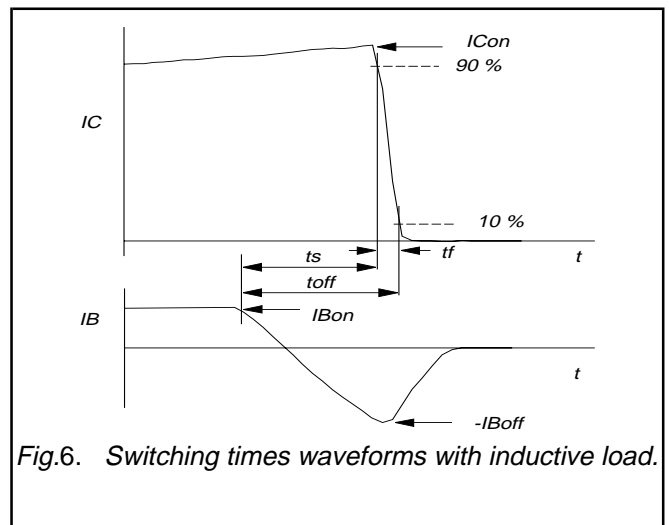
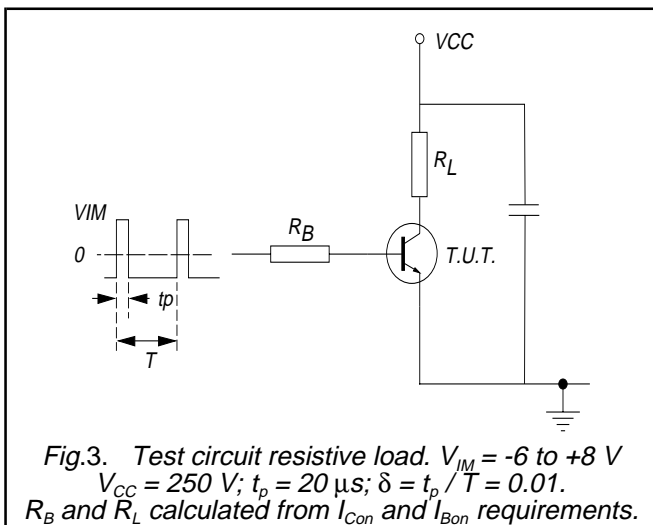
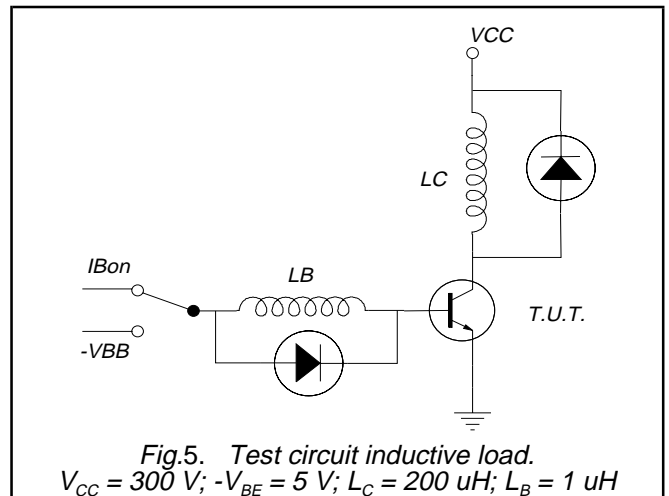
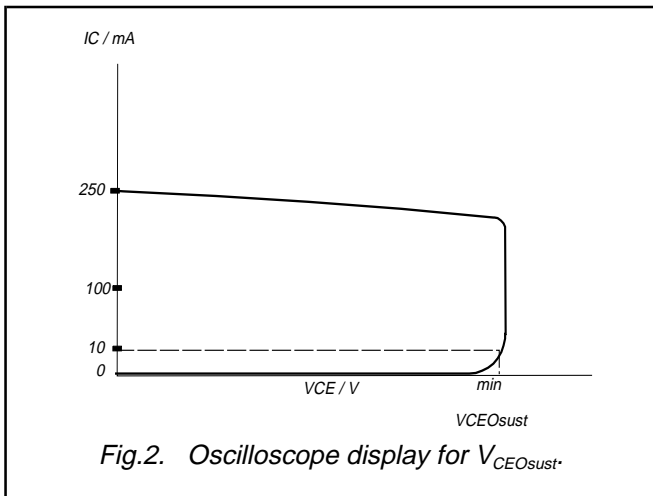
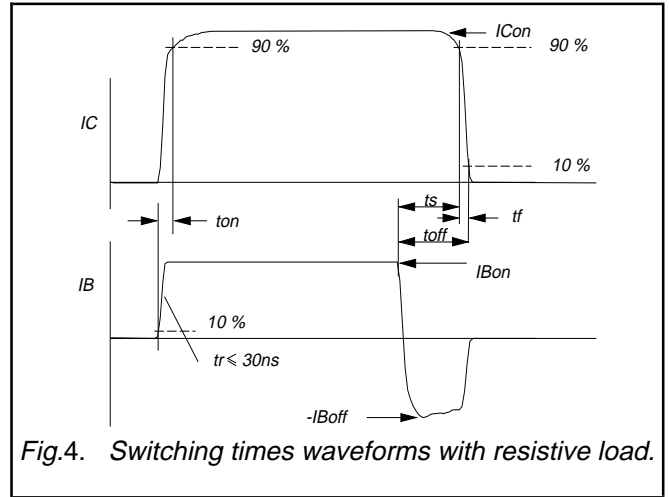
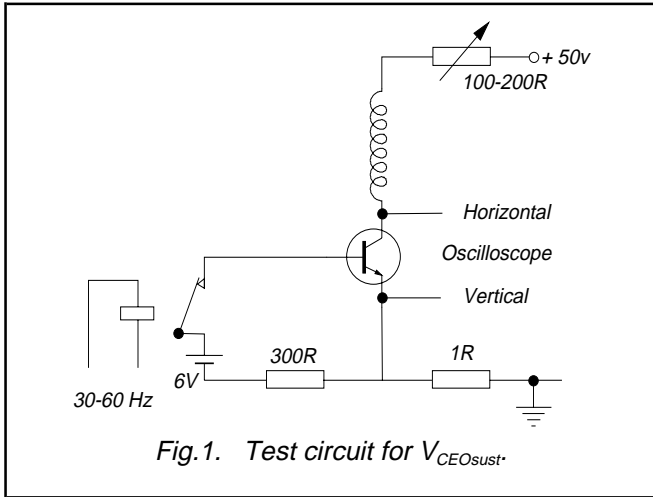

Silicon Diffused Power Transistor

BUJ403BX

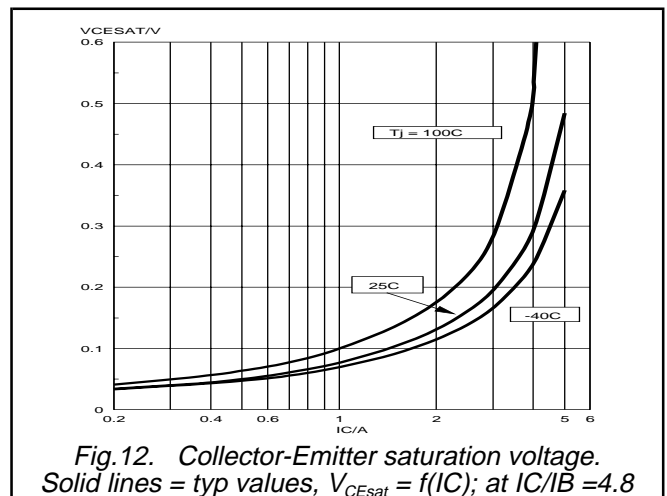
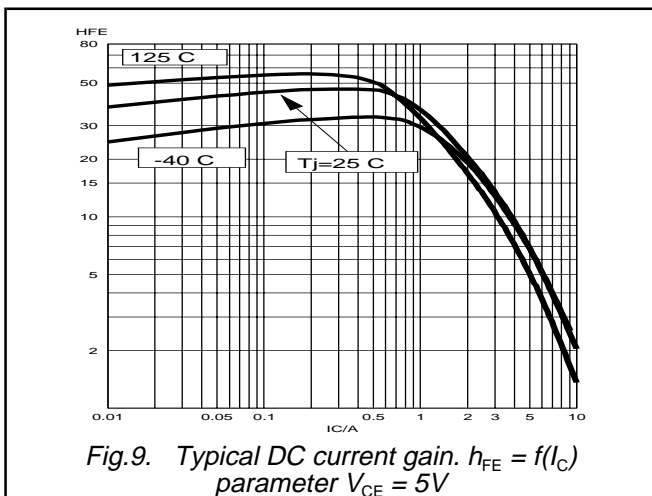
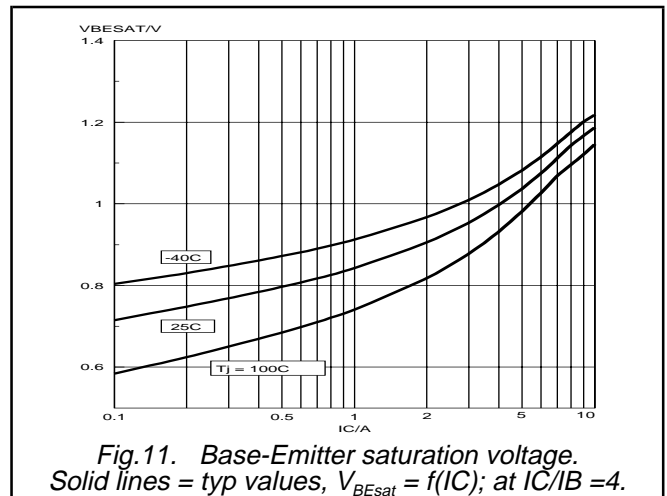
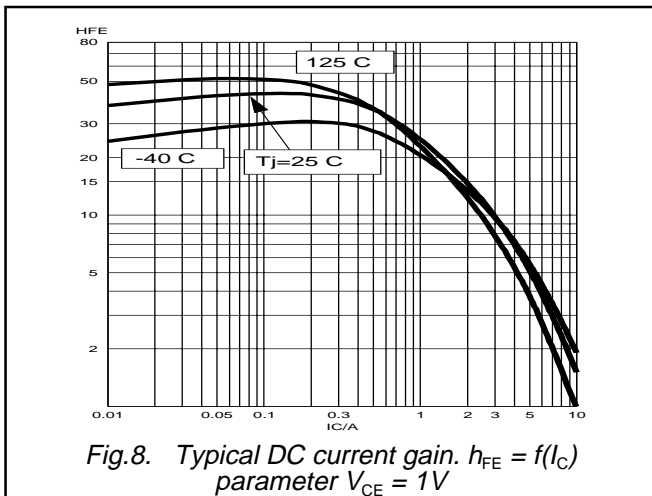
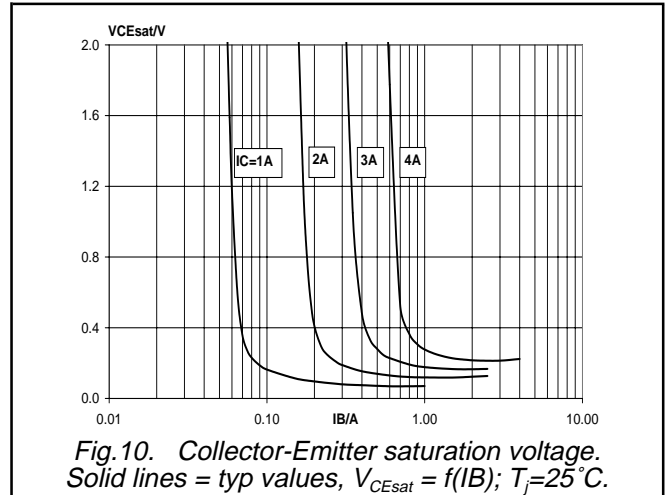
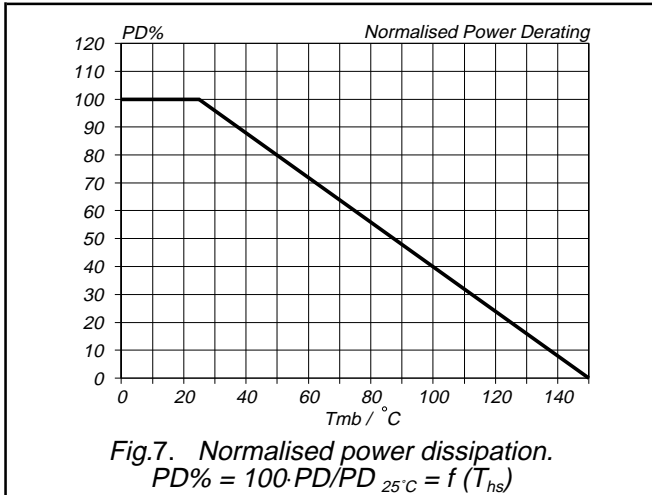

Silicon Diffused Power Transistor

BUJ403BX

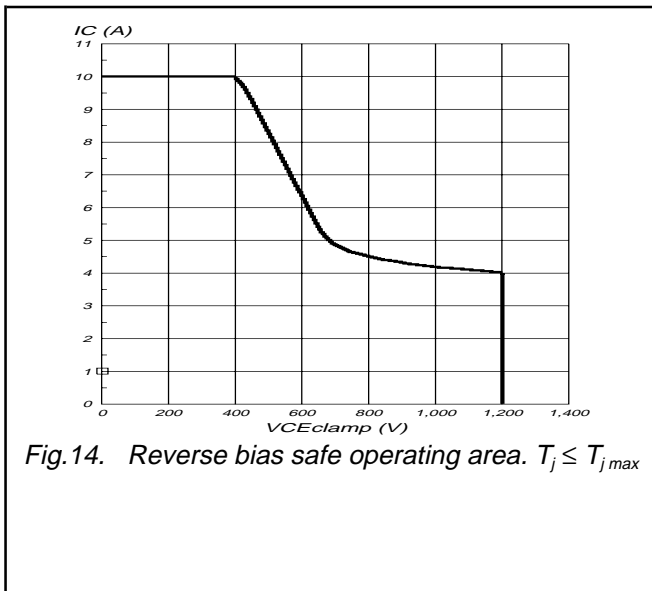
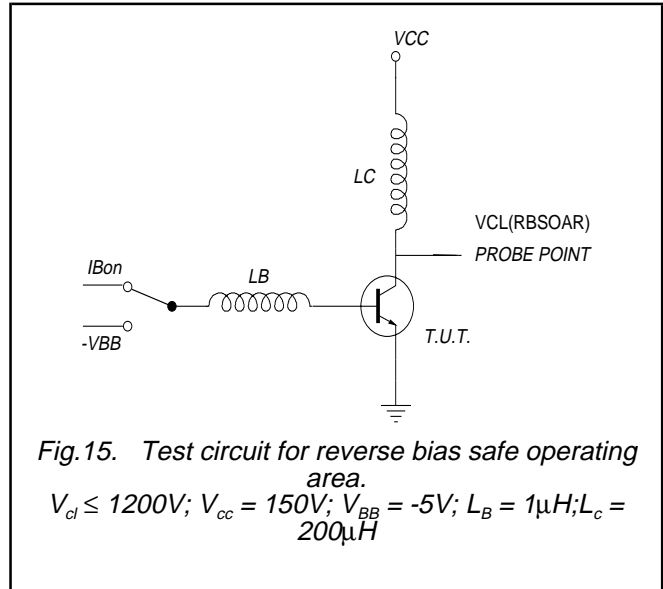
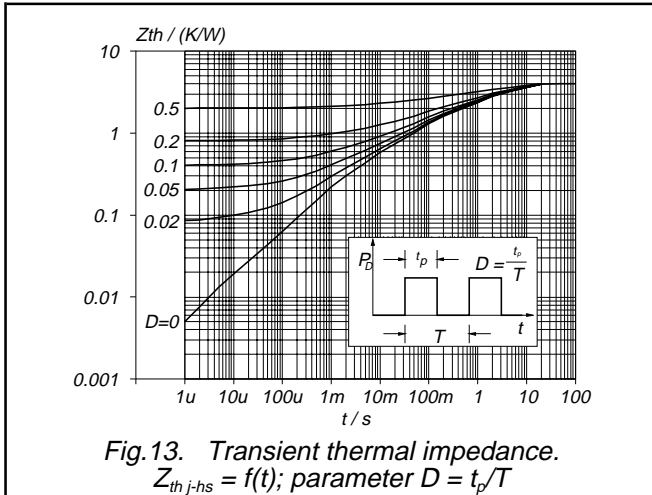

Silicon Diffused Power Transistor

BUJ403BX

MECHANICAL DATA

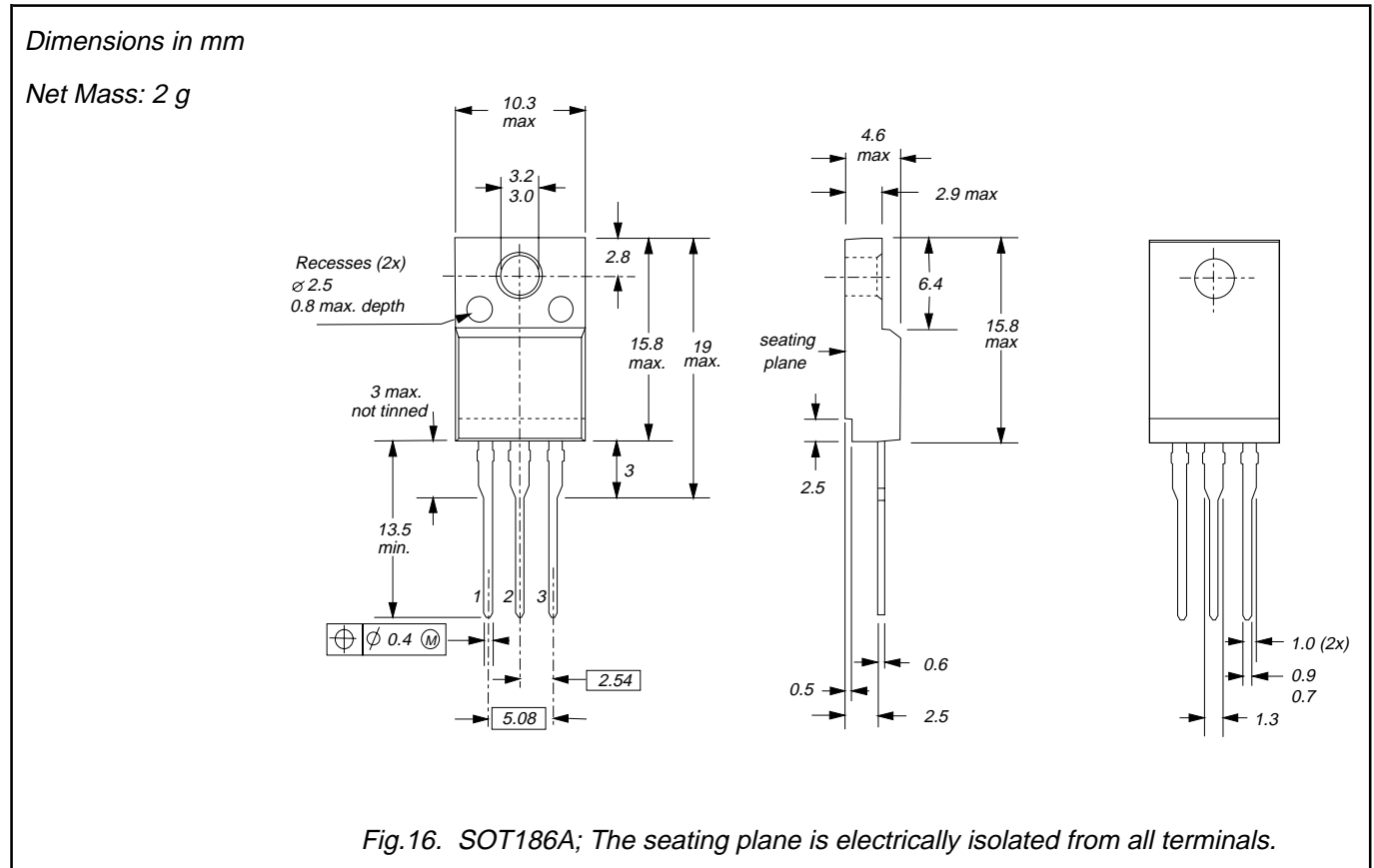

Notes

1. Refer to mounting instructions for F-pack envelopes.
2. Epoxy meets UL94 V0 at 1/8".

Silicon Diffused Power Transistor

BUJ403BX

DEFINITIONS

Data sheet status	
Objective specification	This data sheet contains target or goal specifications for product development.
Preliminary specification	This data sheet contains preliminary data; supplementary data may be published later.
Product specification	This data sheet contains final product specifications.
Limiting values	
Limiting values are given in accordance with the Absolute Maximum Rating System (IEC 134). Stress above one or more of the limiting values may cause permanent damage to the device. These are stress ratings only and operation of the device at these or at any other conditions above those given in the Characteristics sections of this specification is not implied. Exposure to limiting values for extended periods may affect device reliability.	
Application information	
Where application information is given, it is advisory and does not form part of the specification.	
© Philips Electronics N.V. 1999	
All rights are reserved. Reproduction in whole or in part is prohibited without the prior written consent of the copyright owner.	
The information presented in this document does not form part of any quotation or contract, it is believed to be accurate and reliable and may be changed without notice. No liability will be accepted by the publisher for any consequence of its use. Publication thereof does not convey nor imply any license under patent or other industrial or intellectual property rights.	

LIFE SUPPORT APPLICATIONS

These products are not designed for use in life support appliances, devices or systems where malfunction of these products can be reasonably expected to result in personal injury. Philips customers using or selling these products for use in such applications do so at their own risk and agree to fully indemnify Philips for any damages resulting from such improper use or sale.