

LVDS Interface ICs

35bit LVDS Receiver 5:35 DeSerializer

**BU8255KVT**

●Description

LVDS Interface IC of ROHM "Serializer" "Deserializer" operate from 8MHz to 150MHz wide clock range, and number of bits range is from 35 to 70. Data is transmitted seven times (7X) stream and reduce cable number by 3(1/3) or less. The ROHM's LVDS has low swing mode to be able to expect further low EMI.

●Features

- Five channels of LVDS data stream are converted to 35bits data of parallel LVCMOS level outputs.
- 30bits of RGB output data, 5bits of timing and control output data(HSYNC, VSYNC, DE, CTL1 and CTL2) are transmitted available.
- Support clock frequency from 8MHz up to 112MHz.
- Support consumer video format including 480i, 480P, 720P and 1080i as well.
- Support many kinds of PC video formats such as VGA, SVGA, XGA and SXGA.
- Provide 784Mbps per 1ch or 3.92Gbps per device throughput rate using 112MHz clock rate.
- User programmable LVCMOS data output triggering timing by using either rising or falling edge of clock.
- 30bit LVDS transmitter is recommended to use BU8254KVT.

●Applications

Flat Panel Display

◇Precaution

- This chip is not designed to protect from radioactivity.
- The chip is made strictly for the specific application or equipment.
Then it is necessary that the unit is measured as need.
- This document may be used as strategic technical data which subjects to COCOM regulations.

Status of this document

The Japanese version of this document is the formal specification.
A customer may use this translation version only for a reference to help reading the formal version.
If there are any differences in translation version of this document, formal version takes priority.

Jun.2008

● Block Diagram

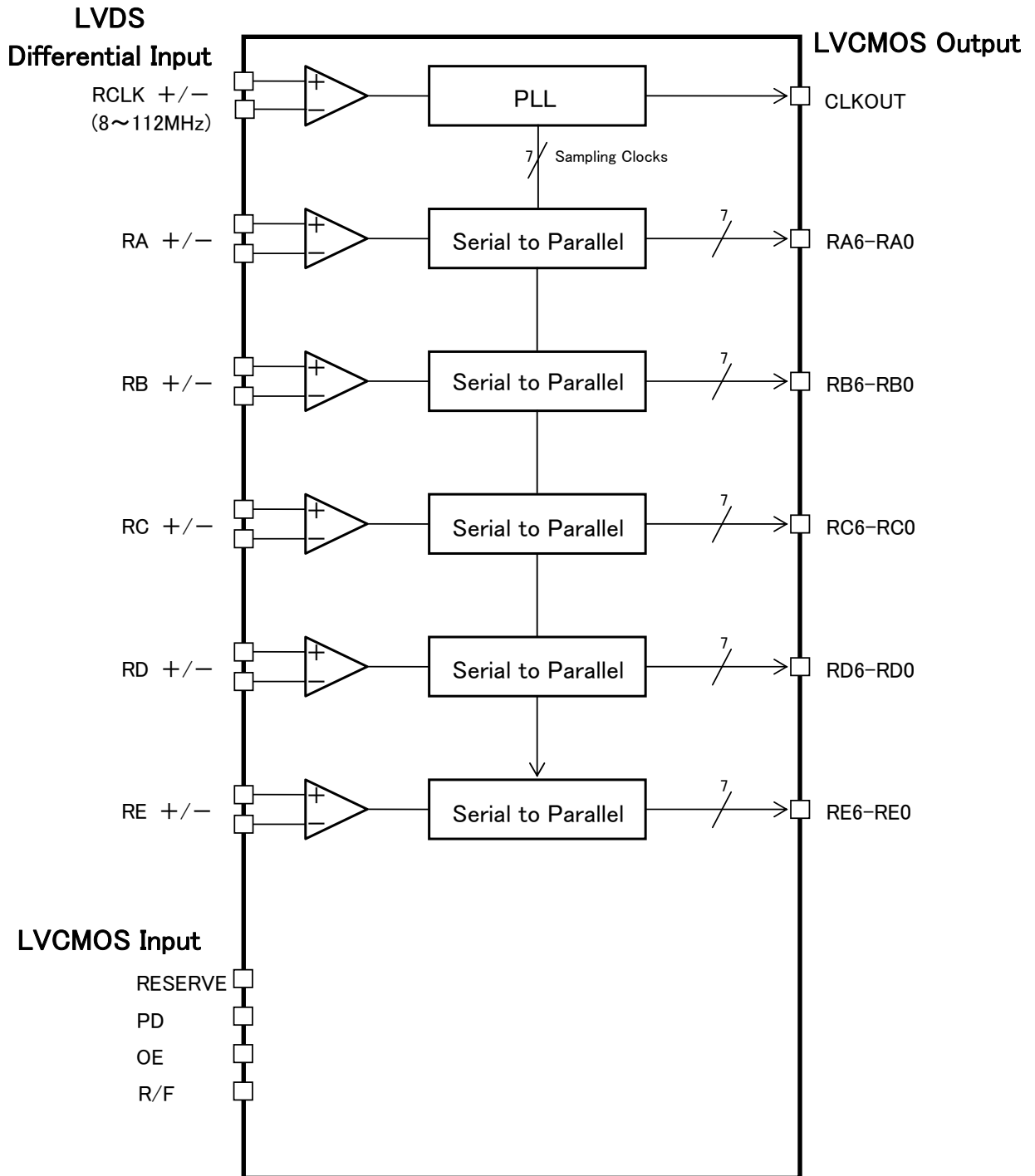
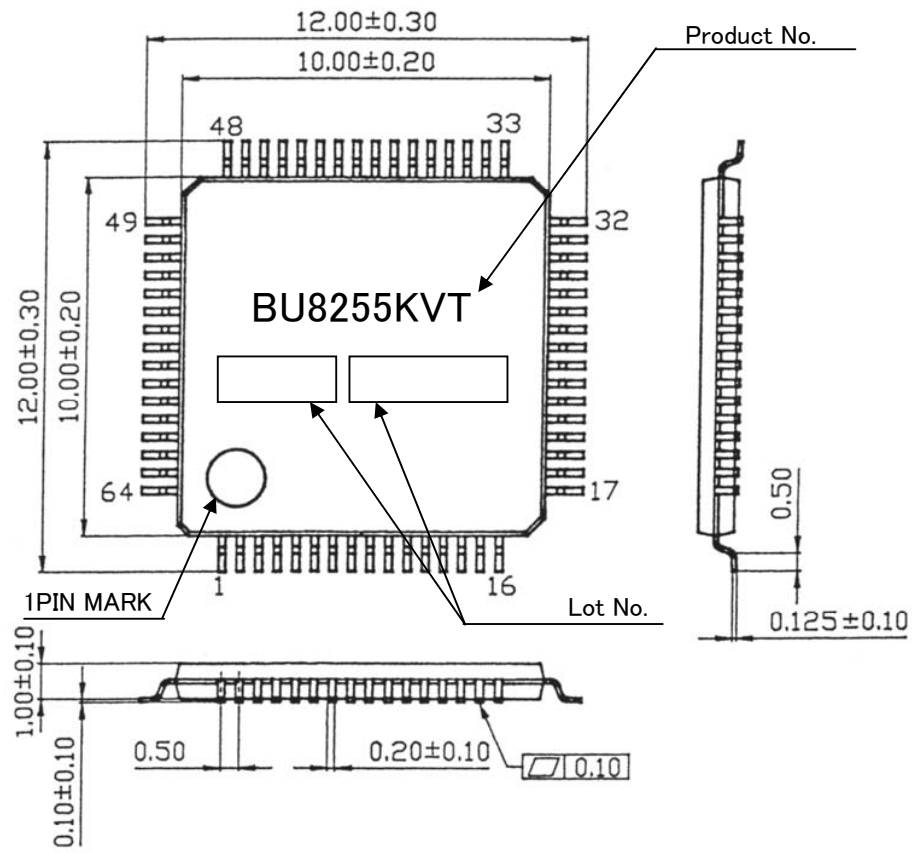

Figure-1 Block Diagram

● TQFP64V Package Specification



(UNIT: mm)

Figure-2 TQFP64V Package

● Pin Diagram

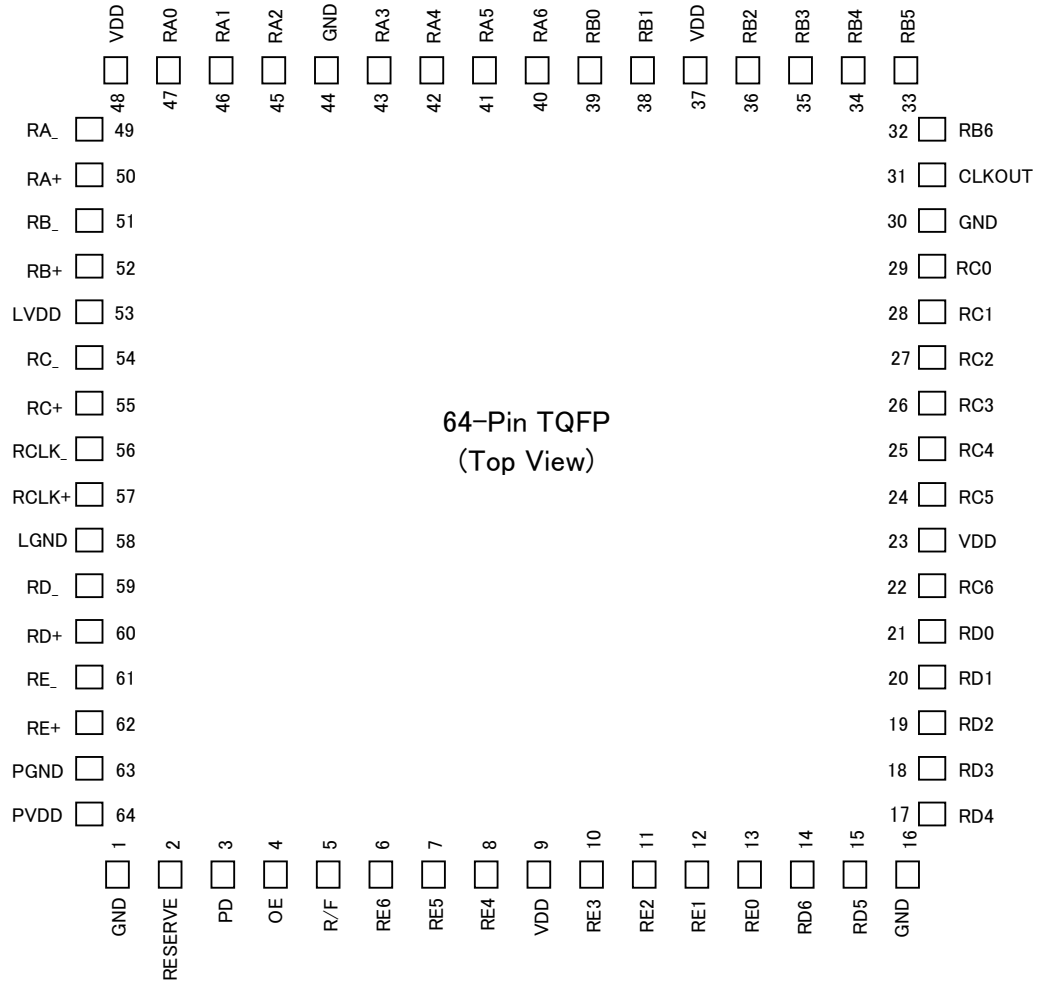

Figure-3 Pin diagram (Top view)

● Pin Description

Table .1: Pin description

Pin Name	Pin No.	I/O	Description
RA+, RA-	50,49	LVDS Input	LVDS data input + : Positive input of LVDS data differential pair. - : Negative input of LVDS data differential pair.
RB+, RB-	52,51	LVDS Input	
RC+, RC-	55,54	LVDS Input	
RD+, RD-	60,59	LVDS Input	
RE+, RE-	62,61	LVDS Input	
RCLK+, RCLK-	57,56	LVDS Input	LVDS clock input
RA6~RA0	40,41,42,43, 45,46,47	Output	LVCMOS data outputs.
RB6~RB0	32,33,34,35, 36,38,39	Output	
RC6~RC0	22,24,25,26, 27,28,29	Output	
RD6~RD0	14,15,17,18, 19,20,21	Output	
RE6~RE0	6,7,8,10,11,1 2,13	Output	
RESERVE	2	Input	Reserved input, must be “Low” for normal operation.
PD	3	Input	Power down input for the internal system. H: Normal operation. L: Power down (All output are “Low”).
OE	4	Input	Power down input for the data output driver. H: Output enable (Normal operation). L: Output disable(All outputs are “Hi-Z”).
R/F	5	Input	Select input pin for data output clock triggering edge. H: Output data is latched on rising edge. L: Output data is latched on falling edge.
VDD	9,23,37,48	Power	3.3V output driver and digital core power supply pin.
CLKOUT	31	Output	LVCMOS level clock output.
GND	1,16,30,44	Ground	GND pin for both data output driver cells and the digital cores.
LVDD	53	Power	Power supply pin for LVDS inputs.
LGND	58	Ground	Ground pin for LVDS inputs.
PVDD	64	Power	Power supply pin for PLL core.
PGND	63	Ground	Ground pin for PLL core.

● Function Description

Table .2: Function explanation list

PD	R/F	OE	Data output (Rxn) *1	Clock output
0	0	0	Hi-Z	Hi-Z
0	0	1	All fixed low	Fixed Low
0	1	0	Hi-Z	Hi-Z
0	1	1	All fixed low	Fixed Low
1	0	0	Hi-Z	Hi-Z
1	0	1	Data output	Output data is latched by falling edge of clock.
1	1	0	Hi-Z	Hi-Z
1	1	1	Data output	Output data is latched by rising edge of clock

*1: Rxn

x = A,B,C,D,E

n = 0,1,2,3,4,5,6

● Electrical Characteristics

■ Rating

Table .3: Absolute maximum rating

Item	Symbol	Value		Unit
		Min.	Max.	
Supply voltage	V_{DD}	-0.3	4.0	V
Input voltage	V_{IN}	-0.3	$V_{DD}+0.3$	V
Output voltage	V_{OUT}	-0.3	$V_{DD}+0.3$	V
Storage temperature range	Tstg	-55	125	°C

Table .4: Package power

Package	PD(mW)	DERATING(mW/°C) *1
TQFP64V	700	7.0
	1000*2	10.0*2

*1 At temperature $T_a > 25^{\circ}\text{C}$

*2 Package power when mounting on the PCB board.

The size of PCB board : $70 \times 70 \times 1.6(\text{mm}^3)$

The material of PCB board :The FR4 glass epoxy board.(3% or less copper foil area)

Table .5: Recommended operating conditions

Item	Symbol	Value			Unit	Condition
		Min.	Typ.	Max.		
Supply voltage	V_{DD}	3.0	3.3	3.6	V	VDD, LVDD, PVDD
Supply Noise Voltage	V_{NOZ}	-	-	0.1	V	
Operating temperature range	Topr	-20	-	85	°C	Clock frequency from 8MHz up to 90MHz
		0	-	70	°C	Clock frequency from 90MHz up to 112MHz

■ DC Characteristics

Table .6: LVCMOS DC character ($V_{DD}=3.0V\sim 3.6V$, $T_a=-20^{\circ}C\sim 85^{\circ}C$)

Symbol	Item	Value			Unit	Condition
		Min.	Typ.	Max.		
V_{IH}	High Input voltage	$V_{DD} \times 0.8$	-	V_{DD}	V	
V_{IL}	Low Input voltage	0.0	-	$V_{DD} \times 0.2$	V	
V_{OH}	High Output voltage	$V_{DD}-0.5$	-	V_{DD}	V	$I_{OH}=-4mA$ (data) $I_{OH}=-8mA$ (clock)
V_{OL}	Low Output voltage	0.0	-	0.4	V	$I_{OL}=4mA$ (data) $I_{OL}=8mA$ (clock)
I_{INC}	Input current	-	-	± 10	μA	$0V \leq V_{IN} \leq V_{DD}$

Table .7: LVDS Receiver DC character ($V_{DD}=3.0V\sim 3.6V$, $T_a=-20^{\circ}C\sim 85^{\circ}C$)

Symbol	Item	Value			Unit	Condition
		Min.	Typ.	Max.		
V_{TH}	Differential input High threshold	-	-	100	mV	$V_{OC}^{*1}=1.2V$
V_{TL}	Differential input Low threshold	-100	-	-	mV	$V_{OC}^{*1}=1.2V$
I_{INL}	Input current	-	-	± 25	μA	$V_{IN}=2.4V / 0V$ $V_{DD}=3.6V$

*1Common Mode Voltage

■ Supply Current

Table .8: Supply current

Symbol	Item	Value		Unit	Condition	
		Min.	Max.			
I_{RCCG}	Receiver supply current (Gray Scale Pattern)	52	-	mA	fCLKOUT=90MHz	$C_L=8\text{pF}$, $V_{DD}=3.3\text{V}$
I_{RCCW}	Receiver supply current (Worst Case Pattern)	95	-	mA	fCLKOUT=90MHz	$C_L=8\text{pF}$, $V_{DD}=3.3\text{V}$
I_{RCCS}	Receiver power down supply current	-	10	μA	PD=L, OE=L	

Gray Scale Pattern

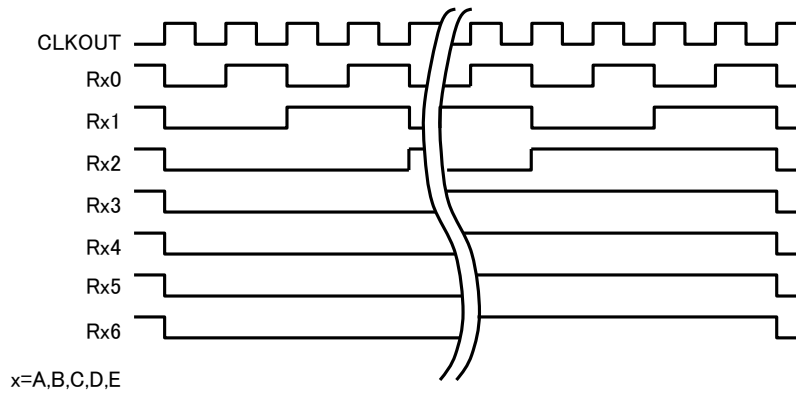

Figure-4 Gray Scale Pattern

Worst Case Pattern (Maximum power condition)

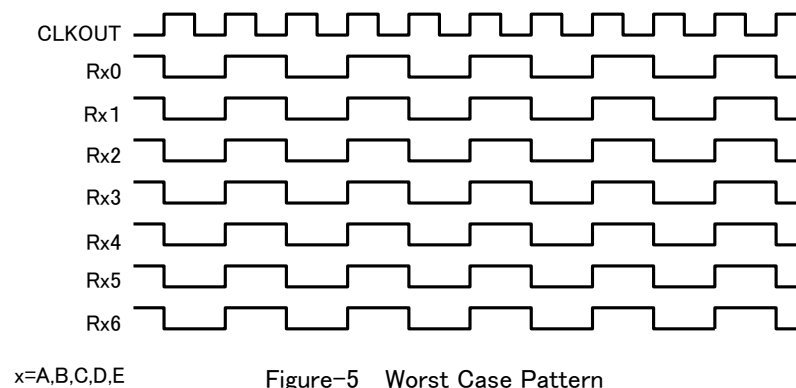

Figure-5 Worst Case Pattern

■ AC Characteristics

Table .9 : Switching characteristics

Symbol	Item	Value			Unit
		Min.	Typ.	Max.	
t_{RCP}	CLKOUT period	8.93	–	125	ns
t_{RCH}	CLKOUT "H" time	–	$0.5t_{RCP}-1.0$	–	ns
t_{RCL}	CLKOUT "L" time	–	$0.5t_{RCP}-1.0$	–	ns
t_{RS}	LVC MOS data setup to CLKOUT	$0.5t_{RCP}-1.4$	–	–	ns
t_{RH}	LVC MOS data hold from CLKOUT	$0.23t_{RCP}-1.0$	–	–	ns
t_{TLH}	LVC MOS data rise time	–	1.0	2.0	ns
t_{THL}	LVC MOS data fall time	–	1.0	2.0	ns
t_{RIP1}	Input data position0	–0.25	0.0	+0.25	ns
t_{RIP0}	Input data position1	$\frac{t_{RCIP}}{7}-0.25$	$\frac{t_{RCIP}}{7}$	$\frac{t_{RCIP}}{7}+0.25$	ns
t_{RIP6}	Input data position2	$2\frac{t_{RCIP}}{7}-0.25$	$2\frac{t_{RCIP}}{7}$	$2\frac{t_{RCIP}}{7}+0.25$	ns
t_{RIP5}	Input data position3	$3\frac{t_{RCIP}}{7}-0.25$	$3\frac{t_{RCIP}}{7}$	$3\frac{t_{RCIP}}{7}+0.25$	ns
t_{RIP4}	Input data position4	$4\frac{t_{RCIP}}{7}-0.25$	$4\frac{t_{RCIP}}{7}$	$4\frac{t_{RCIP}}{7}+0.25$	ns
t_{RIP3}	Input data position5	$5\frac{t_{RCIP}}{7}-0.25$	$5\frac{t_{RCIP}}{7}$	$5\frac{t_{RCIP}}{7}+0.25$	ns
t_{RIP2}	Input data position6	$6\frac{t_{RCIP}}{7}-0.25$	$6\frac{t_{RCIP}}{7}$	$6\frac{t_{RCIP}}{7}+0.25$	ns
t_{RPLL}	Phase Locked Loop set time	–	–	10.0	ms
t_{RCIP}	Clock input period	8.93	–	125	ns

● AC Timing Diagrams

■ LVCMOS

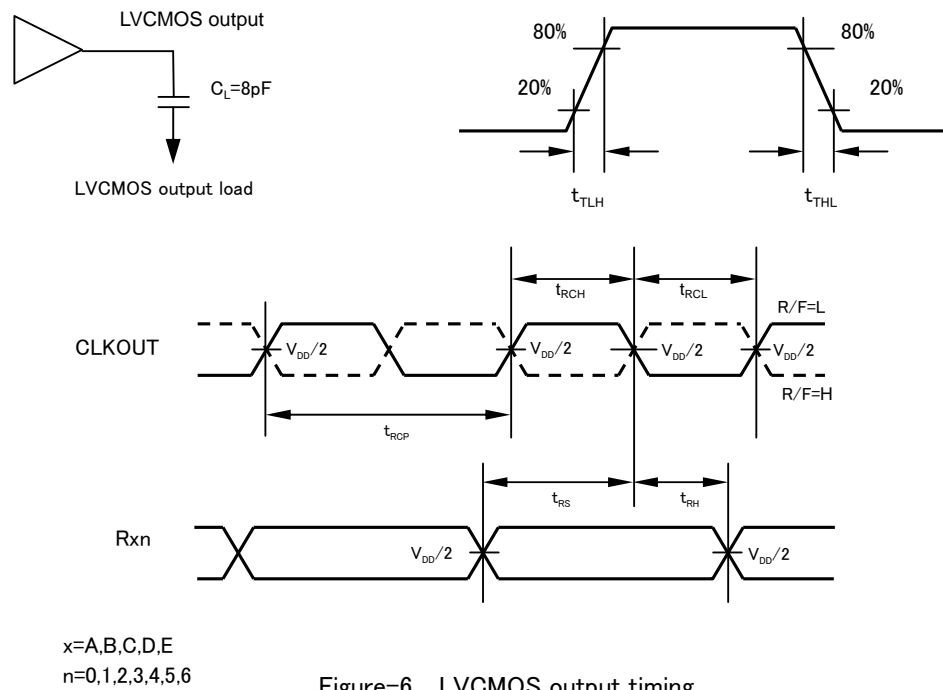

Figure-6 LVCMOS output timing

■ Phase-Locked Loop set time

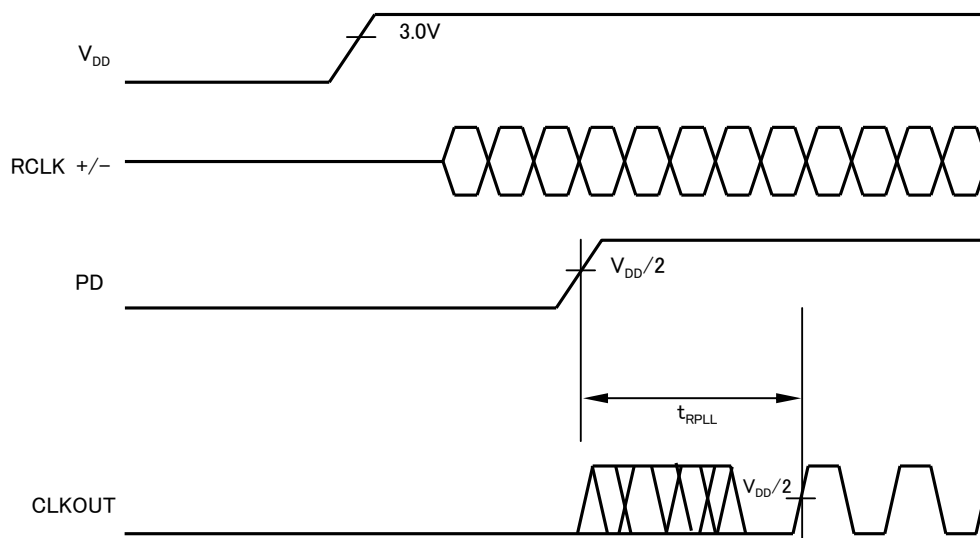

Figure-7 Phase-Locked Loop set time

● LVDS Data, Clock Input Timing

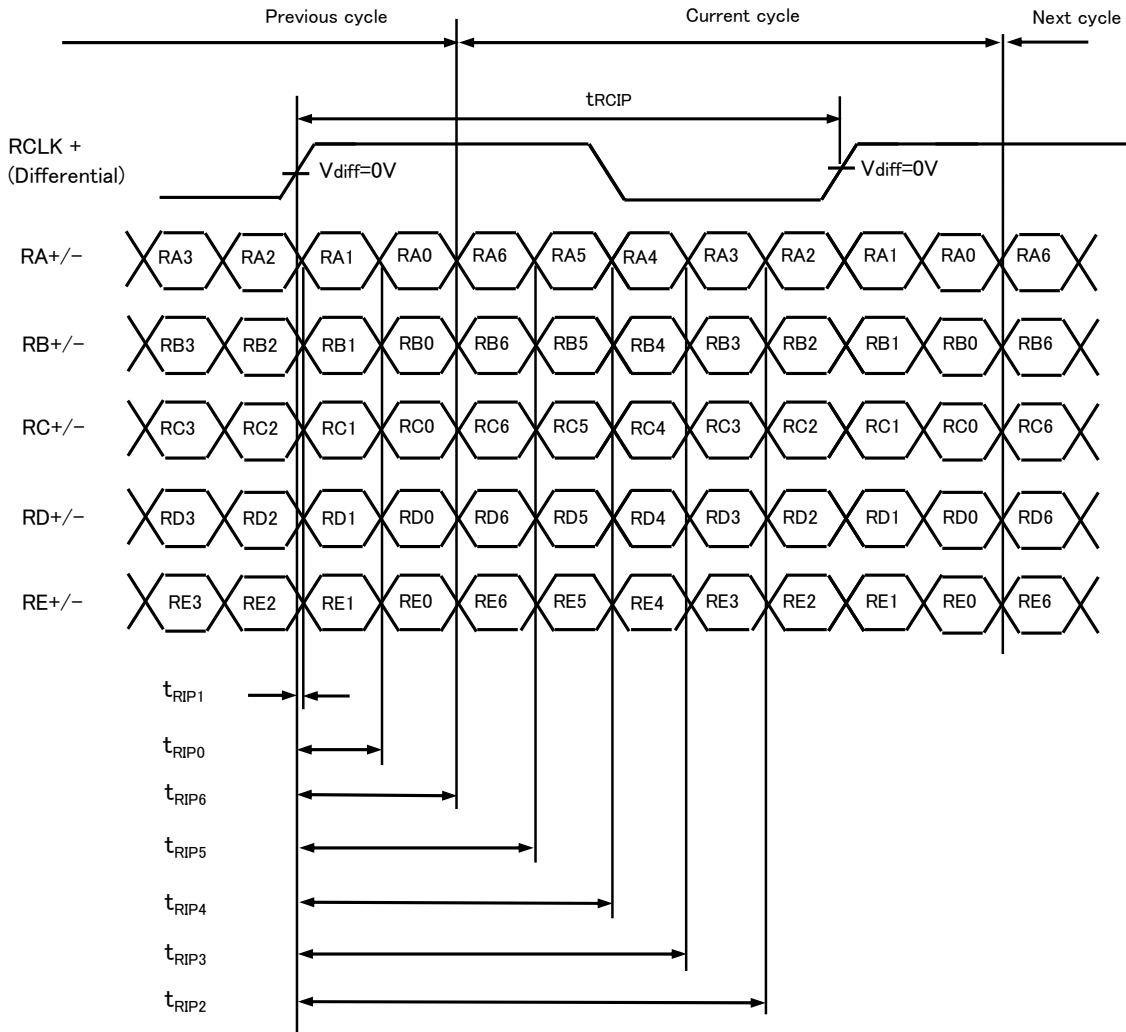

Figure-8 LVDS data and clock input timing

● LVDS Data, Clock Input and LVCMOS Output Timing

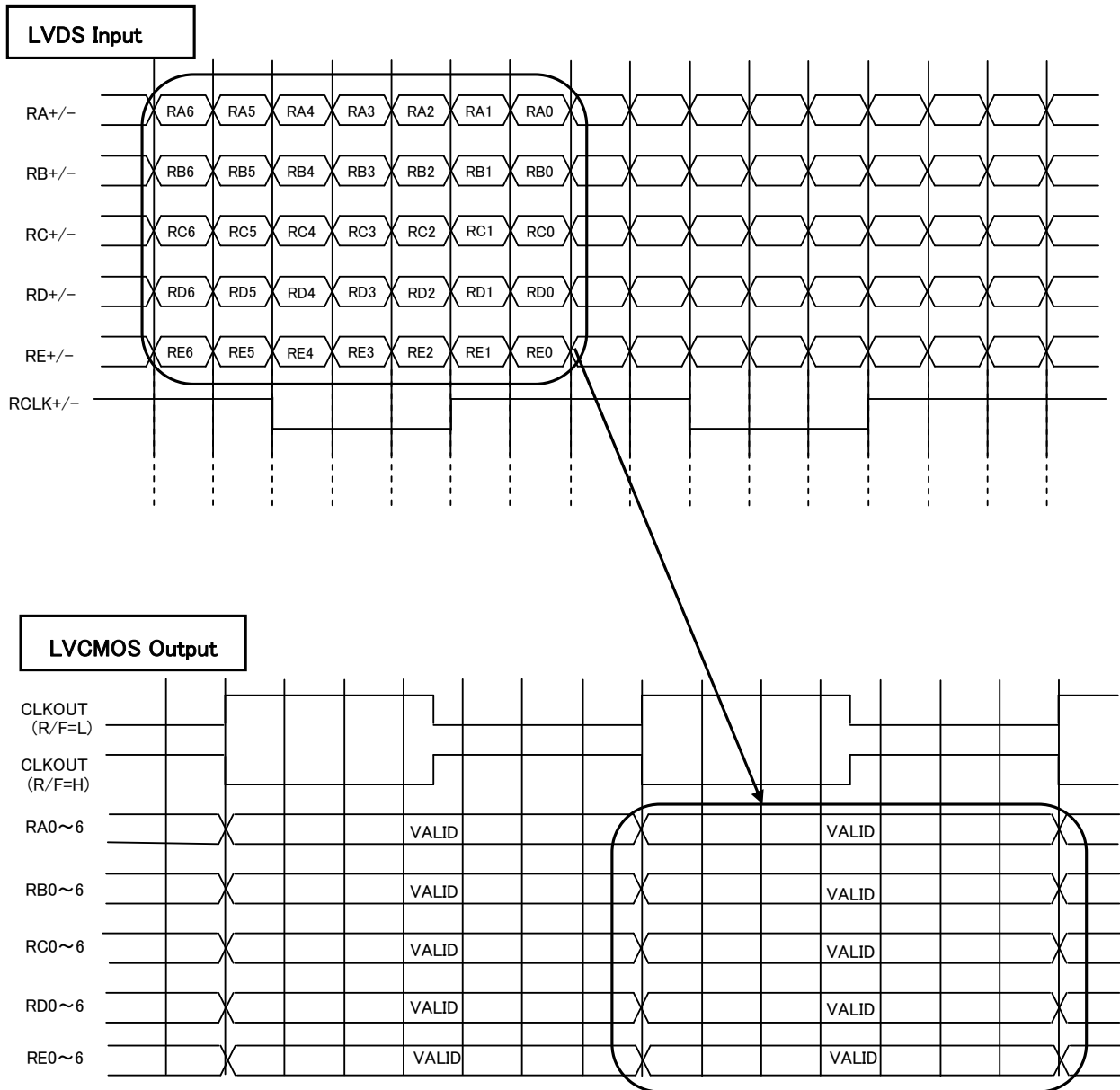

Figure-9 LVDS Data, Clock Input and LVCMOS Output Timing

● About the Power On Reset

Power on reset is not mandatory for this device.

(The PD pin should be set to high level when power on reset procedure is not used.)

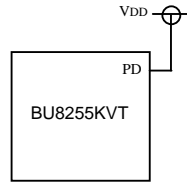

Figure-10 Terminal connection when power on reset is not used.

However, Power on reset procedure is strongly recommend for internal logic initialization by following two methods.

- ① The method of using CR circuit.
- ② The method of using external specific IC.

It is recommend to do enough examination for target application.

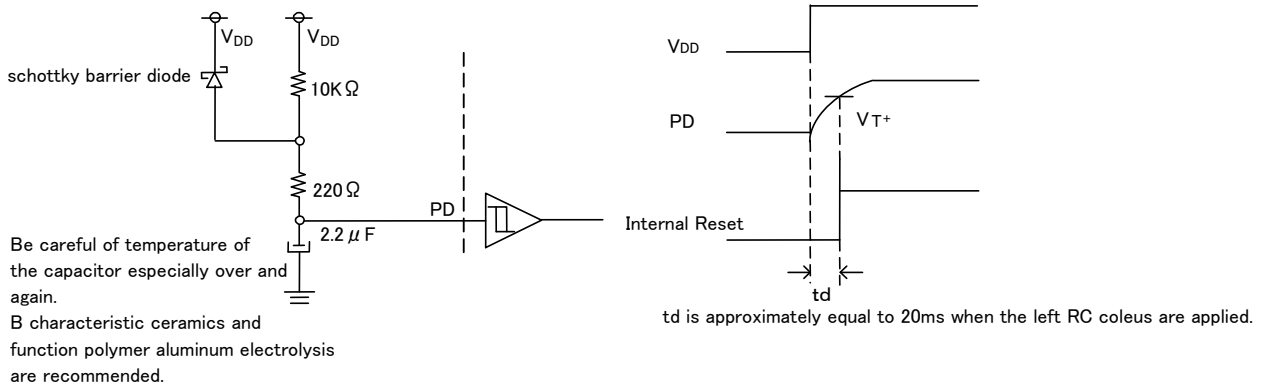

Figure-11 Power on reset by external a CR circuit

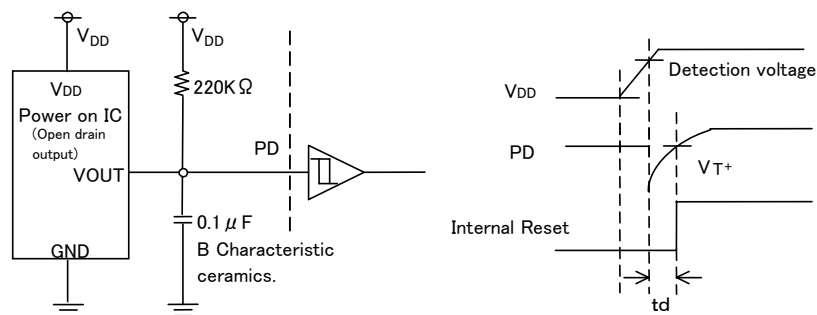

Figure-12 Power on reset by specific IC

● 10 LVDS Level Input & Output

Example:

BU8254KVT : LVCMOS level input/Falling edge/LVDS normal(350mV) swing output

BU8255KVT : LVCMOS level output/Falling edge

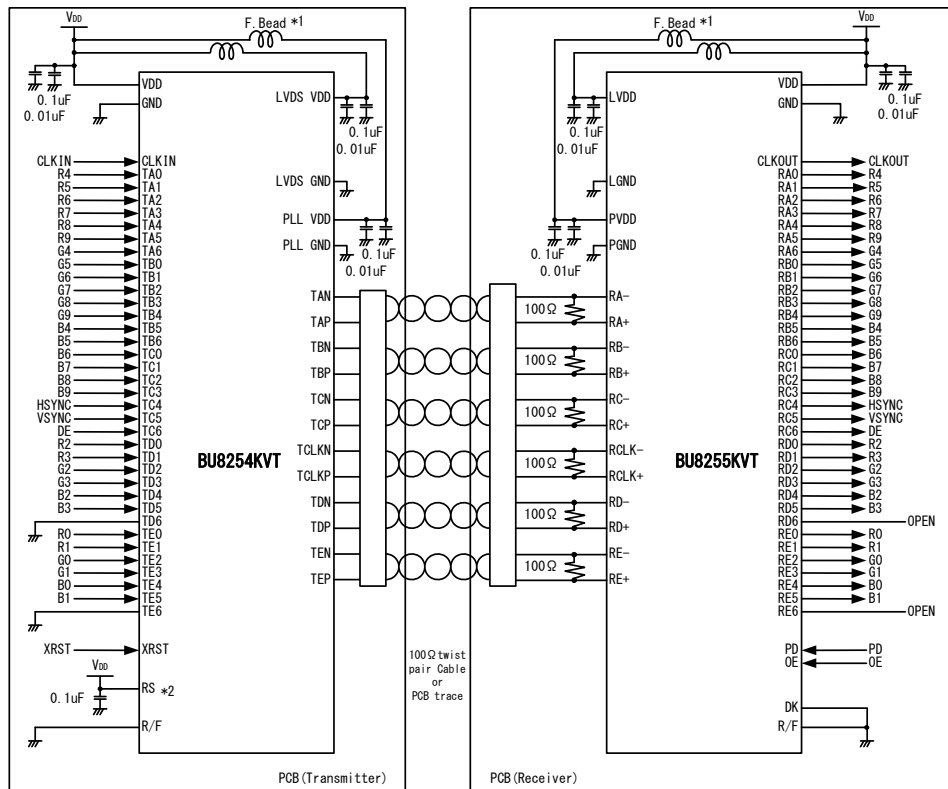

* 1 Recommended Parts:

F.Bead : BLM18A-Series (Murata Manufacturing Co.)

* 2 :If RS pin is tied to V_{DD} , LVDS swing is 350m V.

If RS pin is tied to GND, LVDS swing is 200m V.

● 10bit Small Swing Input & LVCMOS Level Output

Example:

BU8254KVT : LVCMOS level input/Falling edge/LVDS normal(350mV) swing output

BU8255KVT : LVCMOS level output/Falling edge

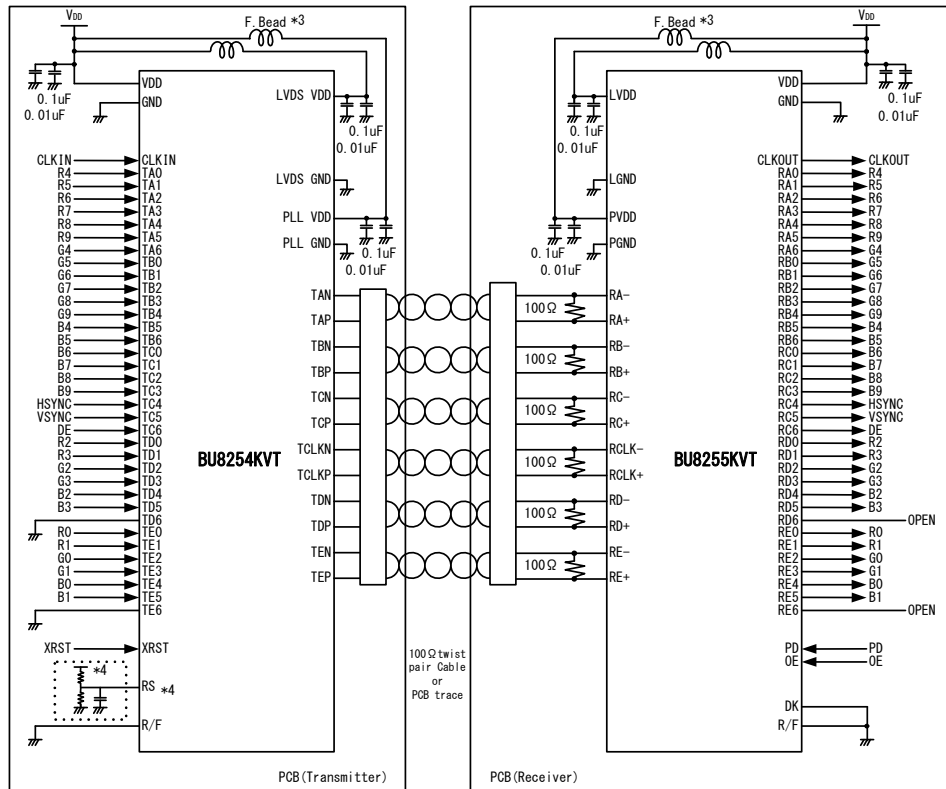

* 3 Recommended Parts:

F.Bead : BLM18A-Series (Murata Manufacturing Co.)

* 4 :RS pin acts as VREF input pin when input voltage is set to half of high level signal input.

We recommend to locate by-pass condenser near the RS pin.

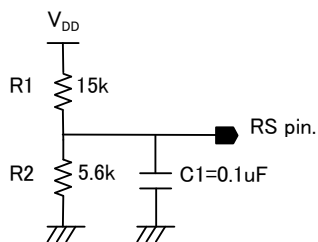

Example for LVTTTL(1.8V input):(R1,R2)=(15kΩ,5.6kΩ)

TQFP64V

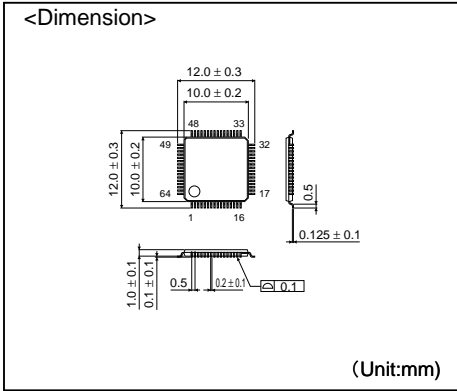

<Packing information>

Container	Tray(with dry pack)
Quantity	1000pcs
Direction of feed	Direction of product is fixed in a tray.

※When you order , please order in times the amount of package quantity.

- The contents described herein are correct as of June, 2008
- The contents described herein are subject to change without notice. For updates of the latest information, please contact and confirm with ROHM CO.,LTD.
- Any part of this application note must not be duplicated or copied without our permission.
- Application circuit diagrams and circuit constants contained herein are shown as examples of standard use and operation. Please pay careful attention to the peripheral conditions when designing circuits and deciding upon circuit constants in the set.
- Any data, including, but not limited to application circuit diagrams and information, described herein are intended only as illustrations of such devices and not as the specifications for such devices. ROHM CO.,LTD. disclaims any warranty that any use of such devices shall be free from infringement of any third party's intellectual property rights or other proprietary rights, and further, assumes no liability of whatsoever nature in the event of any such infringement, or arising from or connected with or related to the use of such devices.
- Upon the sale of any such devices, other than for buyer's right to use such devices itself, resell or otherwise dispose of the same, implied right or license to practice or commercially exploit any intellectual property rights or other proprietary rights owned or controlled by ROHM CO., LTD. is granted to any such buyer.
- The products described herein utilize silicon as the main material.
- The products described herein are not designed to be X ray proof.

The products listed in this catalog are designed to be used with ordinary electronic equipment or devices (such as audio visual equipment, office-automation equipment, communications devices, electrical appliances and electronic toys). Should you intend to use these products with equipment or devices which require an extremely high level of reliability and the malfunction of which would directly endanger human life (such as medical instruments, transportation equipment, aerospace machinery, nuclear-reactor controllers, fuel controllers and other safety devices), please be sure to consult with our sales representative in advance.

Contact us for further information about the products.

Excellence in Electronics

ROHM

ROHM CO., LTD.

21, Saiin Mizosaki-cho, Ukyo-ku, Kyoto
615-8585, Japan
TEL: +81-75-311-2121 FAX: +81-75-315-0172
URL: <http://www.rohm.com>

Published by
LSI Business Promotion Dept.

San Diego	TEL: +1-858-625-3630	FAX: +1-858-625-3670
Atlanta	TEL: +1-770-754-5972	FAX: +1-770-754-0691
Boston	TEL: +1-978-371-0382	FAX: +1-929-438-7164
Chicago	TEL: +1-847-368-1006	FAX: +1-847-368-1008
Dallas	TEL: +1-469-287-6366	FAX: +1-469-362-7973
Denver	TEL: +1-303-708-0908	FAX: +1-303-708-0858
Detroit	TEL: +1-248-348-9920	FAX: +1-248-348-9942
Nashville	TEL: +1-615-620-6700	FAX: +1-615-620-6702
Mexico	TEL: +52-33-3123-2001	FAX: +52-33-3123-2002
Düsseldorf	TEL: +49-2154-9210	FAX: +49-2154-921400
Munich	TEL: +49-8161-48310	FAX: +49-8161-483120
Stuttgart	TEL: +49-711-72723710	FAX: +49-711-72723720
France	TEL: +33-1-5697-3060	FAX: +33-1-5697-3080
United Kingdom	TEL: +44-1-908-306700	FAX: +44-1-908-235788
Denmark	TEL: +45-3694-4739	FAX: +45-3694-4789
Barcelona	TEL: +34-9375-24320	FAX: +34-9375-24410
Hungary	TEL: +36-1-4719338	FAX: +36-1-4719339
Poland	TEL: +48-22-5757213	FAX: +48-22-5757001
Russia	TEL: +7-95-980-6755	FAX: +7-95-937-8290
Seoul	TEL: +82-2-8182-700	FAX: +82-2-8182-715
Masan	TEL: +82-55-240-6234	FAX: +82-55-240-6236
Dalian	TEL: +86-411-8230-8549	FAX: +86-411-8230-8537
Beijing	TEL: +86-10-8525-2493	FAX: +86-10-8525-2489
Tianjin	TEL: +86-22-23029181	FAX: +86-22-23029183

Shanghai	TEL: +86-21-6279-2727	FAX: +86-21-6247-2066
Hangzhou	TEL: +86-571-87658072	FAX: +86-571-87658071
Nanjing	TEL: +86-25-8689-0015	FAX: +86-25-8689-0393
Ningbo	TEL: +86-574-87654201	FAX: +86-574-87654208
Qingdao	TEL: +86-532-5779-312	FAX: +86-532-5779-653
Suzhou	TEL: +86-512-6807-1300	FAX: +86-512-6807-2300
Wuxi	TEL: +86-510-82702693	FAX: +86-510-82702992
Shenzhen	TEL: +86-755-8307-3008	FAX: +86-755-8307-3003
Dongguan	TEL: +86-769-8393-3320	FAX: +86-769-8398-4140
Fuzhou	TEL: +86-591-8801-8698	FAX: +86-591-8801-8690
Guangzhou	TEL: +86-20-8364-9796	FAX: +86-20-8364-9707
Huizhou	TEL: +86-752-205-1054	FAX: +86-752-205-1059
Xiamen	TEL: +86-592-238-5705	FAX: +86-592-239-8380
Zhuhai	TEL: +86-756-3232-480	FAX: +86-756-3232-460
Hong Kong	TEL: +852-2-740-6262	FAX: +852-2-375-8971
Taipei	TEL: +886-2-2500-6956	FAX: +886-2-2503-2869
Kaohsiung	TEL: +886-7-237-0881	FAX: +886-7-238-7332
Singapore	TEL: +65-6332-2322	FAX: +65-6332-5662
Philippines	TEL: +63-2-807-6872	FAX: +63-2-809-1422
Thailand	TEL: +66-2-254-4890	FAX: +66-2-256-6334
Kuala Lumpur	TEL: +60-3-7958-8355	FAX: +60-3-7958-8377
Penang	TEL: +60-4-2286453	FAX: +60-4-2286452
Kyoto	TEL: +81-75-365-1218	FAX: +81-75-365-1228
Yokohama	TEL: +81-45-476-2290	FAX: +81-45-476-2295

Catalog No.08T238A 08.6 ROHM ©