

INFRARED REMOTE CONTROL RECEIVER

■ GENERAL DESCRIPTION

NJL35V/38H000 series are small and high performance receiving devices for infrared remote control system.

They can operate under low and wide supply voltage (2.7V to 5.5V). NJL35V/38H000 series are mesh window type to improve EMI characteristic. Even under strong EMI noise condition such as TV, Air-conditioner, etc., NJL25V/28H000 series can work normally.

■ FEATURES

1. Wide and low supply voltage 2.7V to 5.5V
2. Low supply current 0.43mA typ. $V_{cc}=3.3V$
3. Metal case type with mesh window
4. Line-up for various center carrier frequencies

■ APPLICATIONS

1. Home application such as Room light Air-conditioner, etc.
2. AV instruments such as Audio, TV, DVD, STB etc.

■ LINE-UP

View Type	Side	Top
Height		
Carrier Frequency	15.6mm	15mm
fo= 36 kHz	NJL35V360	NJL38H360
36.7 kHz	NJL35V367	NJL38H367
38 kHz	NJL35V380	NJL38H380
40 kHz	NJL35V400	NJL38H400

Regarding the other frequency or packages, please contact to New JRC individually.

■ BLOCK DIAGRAM

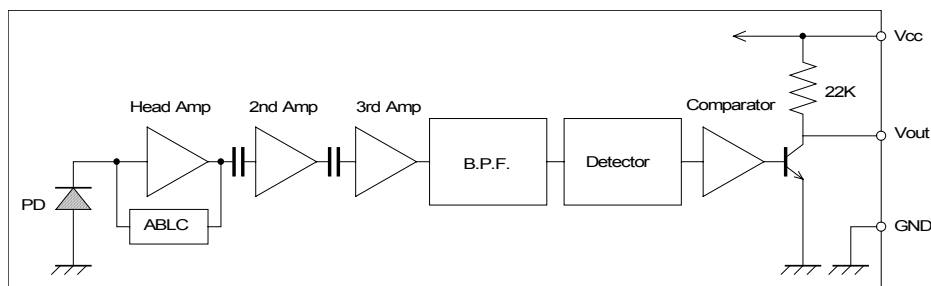

■ ABSOLUTE MAXIMUM RATINGS (Ta=25°C)

PARAMETER	SYMBOL	RATINGS	UNIT
Supply Voltage	V_{cc}	6.3	V
Operating Temperature Range	T_{opr}	-30 to +80	°C
Storage Temperature Range	T_{stg}	-40 to +85	°C
Soldering Temperature	T_{sol}	260 (5sec. 4.0mm from mold body)	°C

NJL35V/38H000

RECOMMENDED OPERATING CONDITION

Supply Voltage Range V_{cc} 2.7 V to 5.5V

ELECTRO-OPTICAL CHARACTERISTICS ($V_{cc}=3.3V, T_a=25^\circ C$)

PARAMETER	SYMBOL	TEST CONDITION	MIN	TYP	MAX	UNIT
Supply Current	I_{cc}	No Signal Input	—	0.43	0.56	mA
Transmission Distance	L_c	Direction of Ray Axis *1	10	15	—	m
Directivity	θ_L	Angle of half L_c , Horizontal *2	—	45	—	deg
	θ_V	Angle of half L_c , Vertical *2	—	30	—	deg
Output Voltage Low	V_L	No Load	—	0.2	0.5	V
Output Voltage High	V_H	No Load	2.8	—	—	V
Low Level Pulse Width	T_{wL}	See Test Circuit	400	—	950	μs
High Level Pulse Width	T_{wH}	See Test Circuit	250	—	800	μs
Center Carrier Frequency	f_o	See Line-up	—	*3	—	kHz

Note *1: Test with each center carrier frequency under the test condition shown below.

*2: Place major axis of elliptic lens in horizontal direction and minor vertical.

*3: Four types of frequency :36.0, 36.7, 38.0, 40.0kHz

TEST METHOD

Test condition is as follows:

(1) Standard transmitter:

Transmitting waveform is shown in Fig.1
 Transmitting power should be adjusted so that output voltage V_{out} will be 400mVp-p. (Test circuit is shown in Fig.2)
 Regarding IR LED used for transmitter,
 $\lambda_p=940nm, \Delta\lambda=50nm$.

Regarding photo diode,
 Sensitivity $S=26nA/Lx$
 in case light source temperature $2856^\circ K$,
 $E_e=100Lx, V_R=5V$

(2) Test system: Shown in Fig.3.

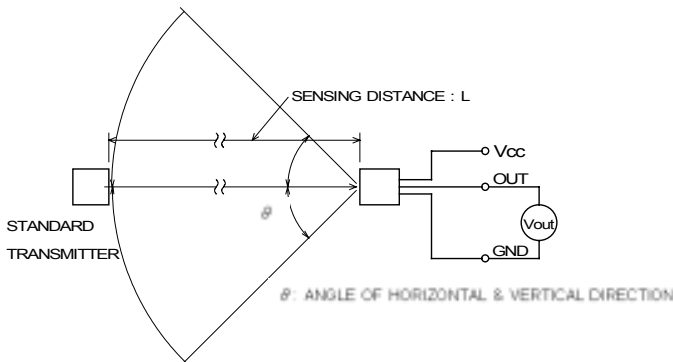

Fig.3 TEST SYSTEM

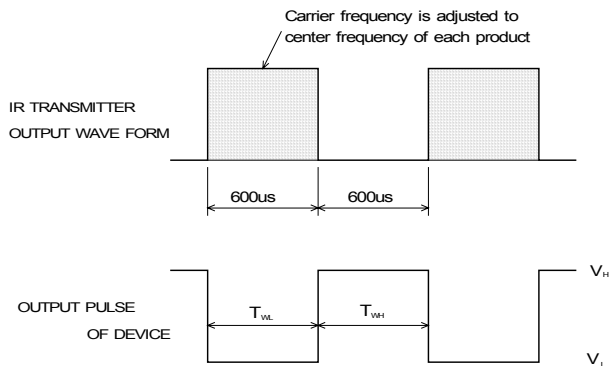

Fig.1 TRANSMITTER WAVE FORM

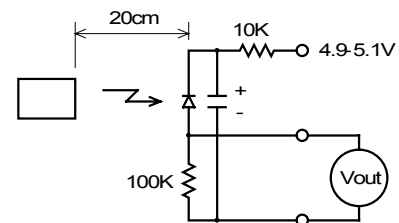
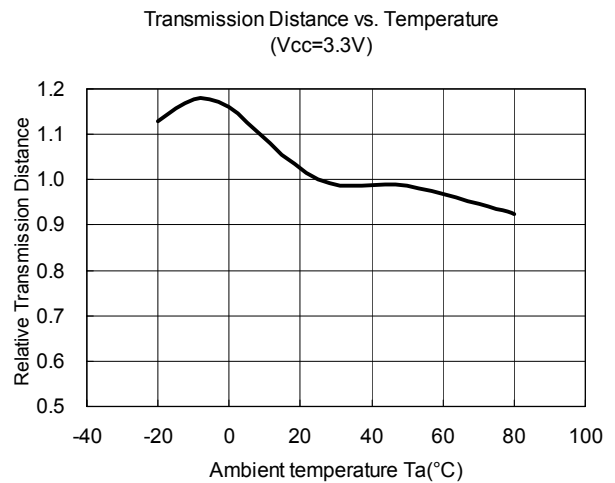
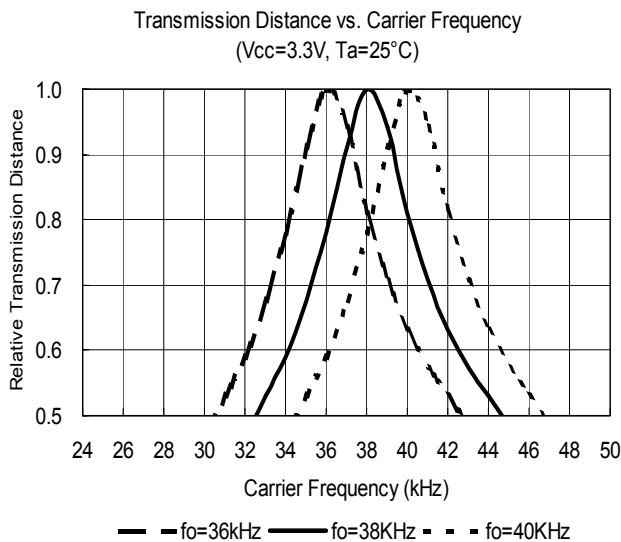
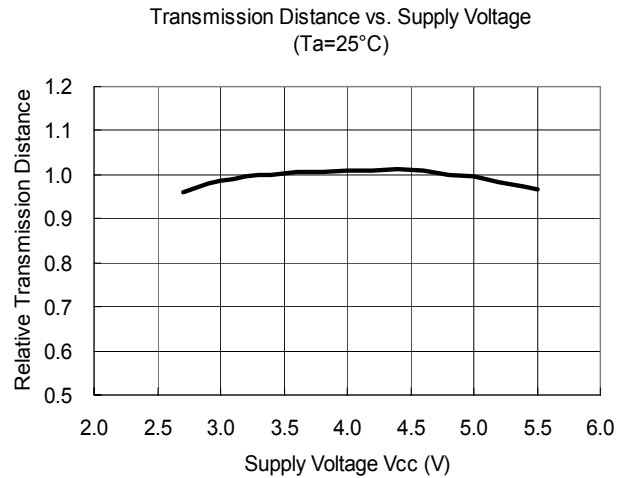
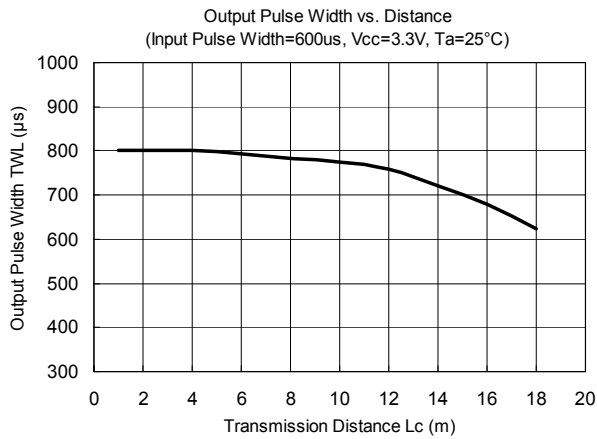
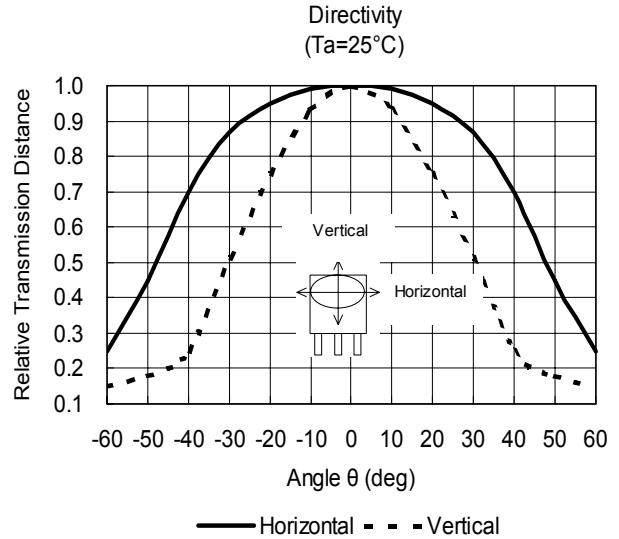
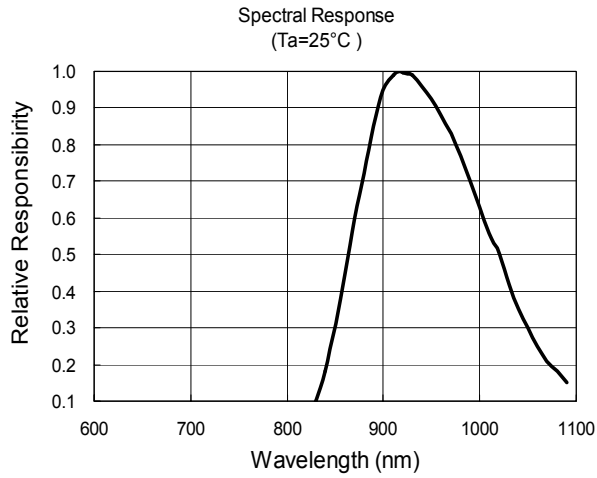

Fig.2 STD. TRANSMITTER TEST CIRCUIT

TYPICAL CHARACTERISTICS



NJL35V/38H000

RECOMMENDED APPLICATION CIRCUIT

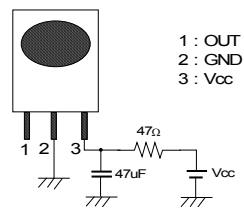

RC Filter should be connected closely between Vcc pin and GND pin.

OUTLINE

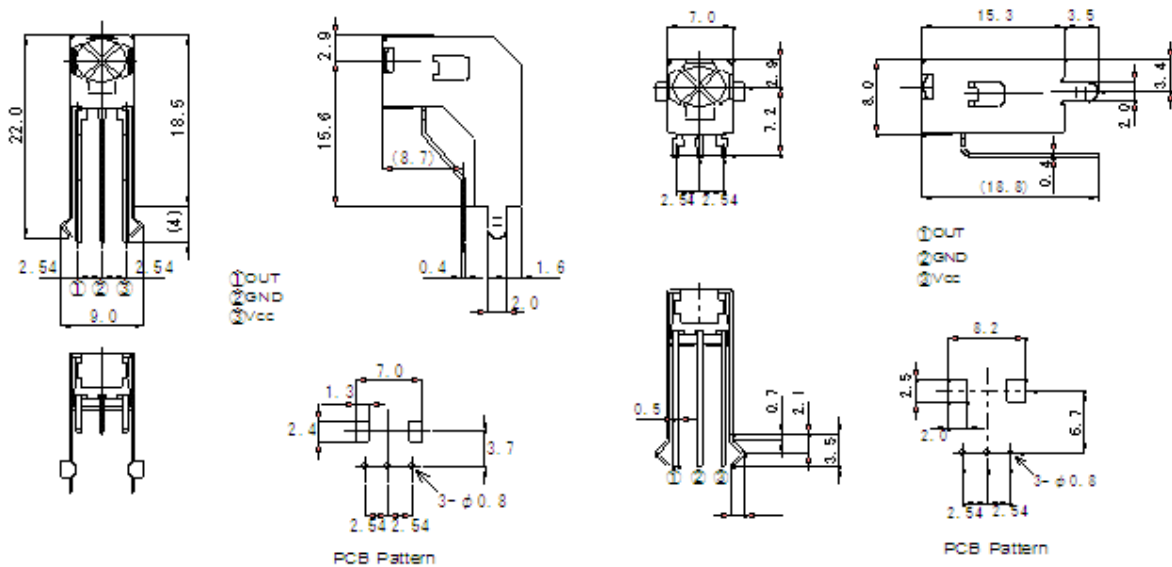

NJL35V000
UNIT:mm

NJL35H000
UNIT:mm

- 1.Tolerance is ± 0.3 mm unless otherwise noted.
- 2.Ground metal case on PCB. Metal case is not connected to GND pin inside.Tolerance is ± 0.3 mm unless otherwise noted.

[CAUTION]

The specifications on this databook are only given for information , without any guarantee as regards either mistakes or omissions. The application circuits in this databook are described only to show representative usages of the product and not intended for the guarantee or permission of any right including the industrial rights.