

Structure	Silicon Monolithic Integrated Circuit
Product series	PWM Driver for combi drive
Type	BD7791FUV
Function	<ul style="list-style-type: none"> • 3-phase-sensor-less system, therefore don't need three hall sensors for spindle motor driver. • Stability high-speed start from the state of the stop for spindle motor driver.

○ Absolute maximum ratings

Parameter	Symbol	Limits	Unit
Power MOS supply voltage	PVcc	6	V
Control circuit power supply voltage	Vcc	6	V
Maximum driver output current	IoMAX	3 # 1	A
Power dissipation	Pd	1.37 # 2	W
Operating temperature range	Topr	-30~85	°C
Storage temperature range	Tstg	-55~150	°C
Joint part temperature	Tjmax	150	°C

#1 The current is guaranteed 3.0A in case of the current is turned on/off in a duty-ratio of less than 1/10 with a maximum on-time of 5ms and when short brake.

#2 PCB (70mm×70mm×1.6mm,occupied copper foil is less than 3%,glass epoxy standard board) mounting.
Reduce power by 11.0 mW for each degree above 25°C.

○ Recommended operating conditions(Ta=-30~+85°C)

(Set the power supply voltage taking allowable dissipation into considering)

Parameter	Symbol	MIN	TYP	MAX	Unit
Power MOS supply voltage	PVcc	4.0	5.0	5.5	V
Control circuit power supply voltage	Vcc	4.0	5.0	5.5	V

This product isn't designed for protection against radioactive rays.

Status of this document

The Japanese version of this document is the formal specification.
A customer may use this translation version only for a reference to help reading the formal version.
If there are any differences in translation version of this document , formal version takes priority.

○Electrical characteristics

(Unless otherwise noted Ta=25°C, Vcc=PVcc=5V, Vref=1.25V, RL(ACT,STP,LOAD)=8Ω+47μH, RL(SP)=2Ω+47μH, RNF=0.2Ω, CTL1,2=3.3V, GVSW=0V, VIN1,2,3,4,5,6=OPEN, VCOM=OPEN, VCCOM=OPEN, VCOUT=OPEN)

Parameter		Symbol	MIN.	TYP.	MAX.	Unit	Condition
Circuit current	Quiescent current	ICC	—	8	20	mA	CTL1,2=H
	Current in standby mode	IST	—	—	0.2	mA	CTL1,2=L
Actuator driver block	Input dead zone (one side)	VDZACT1,2,3	—	—	3	mV	
	Output offset voltage	VOO1,2,3	-50	—	50	mV	Voltage gain 1, 2
	Voltage gain 1 (CH1,2,3)	GVC1_1,2,3	15.5	17.5	19.5	dB	External input resistor 10kΩ
	Voltage gain 2 (CH1,2)	GVC2_1,2	10	12	14	dB	External input resistor 10kΩ, GVSW=H
	Output On resistor (top and bottom)	RON1,2,3	—	1.2	1.8	Ω	Io=500mA
	PWM frequency	f1,2,3CH	215	310	405	kHz	Voltage gain 1, 2
Stepping driver block	Input dead zone (one side)	VDZ4,5	10	30	50	mV	
	Output offset voltage	VOO4,5	-50	—	50	mV	
	Voltage gain	GVC4,5	15.5	17.5	19.5	dB	
	Output On resistor (top and bottom)	RON4,5	—	1.6	2.4	Ω	Io=500mA
Loading driver block	Input dead zone (one side)	VDZ6	20	60	100	mV	CTL1=H, CTL2=L
	Output offset voltage	VOO6	-50	—	50	mV	CTL1=H, CTL2=L
	Voltage gain	GVC6	15.5	17.5	19.5	dB	CTL1=H, CTL2=L
	Output On resistor (top and bottom)	RON6	—	1.8	2.7	Ω	Io=500mA, CTL1=H, CTL2=L
	PWM frequency	f6CH	215	310	405	kHz	CTL1=H, CTL2=L
Spindle driver block	Input dead zone of gm1(one side)	VDZSP1	2	30	100	mV	
	Input dead zone of gm2(one side)	VDZSP2	6	90	300	mV	GVSW=M
	Input dead zone of gm3(one side)	VDZSP3	10	150	500	mV	GVSW=H
	Input output gain 1	gm1	0.88	1.1	1.32	A/V	
	Input output gain 2	gm2	0.28	0.36	0.44	A/V	GVSW=M
	Input output gain 3	gm3	0.17	0.22	0.27	A/V	GVSW=H
	Output On resistor (top and bottom)	RONSP	—	0.6	1.4	Ω	Io=500mA
	Output limit voltage	VLIMSP	0.18	0.22	0.26	V	
Others	PWM frequency	fSP	—	167	—	kHz	
	Vref drop mute ON threshold voltage	VMVref	—	0.7	1.0	V	
	Vcc drop mute ON threshold voltage	VMVccD	3.2	3.6	4.0	V	
	CTL1 L voltage	VCTL1L	0	—	1.0	V	
	CTL1 H voltage	VCTL1H	2.0	—	3.3	V	
	CTL2, GVSW L voltage	VCTL2L, VGVL	0	—	1.0	V	
	CTL2, GVSW M(Hi-z) voltage	VCTL2M, VGVM	1.6	—	2.0	V	OPEN (Hi-z) is also available.
CTL2, GVSW H voltage	VCTL2H, VGVH	2.6	—	3.3	V		

GVSW	L	M (Hi-z)	H
Spindle gain mode	gm1	gm2	gm3
CH1,2 gain mode	GVC1_1,2		GVC2_1,2

CTL1	CTL2	Brake mode	SPINDLE Output	CH1,2,3 Output	CH4,5 Output	CH6 Output
L	L	—	Hi-Z	Hi-Z	Hi-Z	Hi-Z
	M	Short brake	ACTIVE	Hi-Z	Hi-Z	Hi-Z
	H		ACTIVE	ACTIVE	ACTIVE	Hi-Z
H	L	Reverse brake	Hi-Z	Hi-Z	ACTIVE	ACTIVE
	M (Hi-z)		ACTIVE	Hi-Z	Hi-Z	Hi-Z
	H		ACTIVE	ACTIVE	ACTIVE	Hi-Z

Please supply the middle level voltage for CTL2 when using it in the mode of CTL1=L and CTL2=M.

○Package outlines

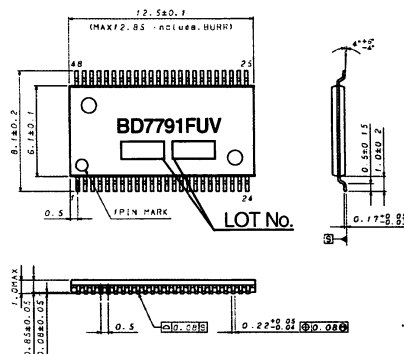

(UNIT : mm)

○Block diagram / Application circuit

The external constants concerning CH1,2 are values optimized in case $4\Omega+47\mu\text{H}$ is assumed as a load, and those concerning CH3 are values optimized in case $4\Omega+10\mu\text{H}$ is assumed as a load.

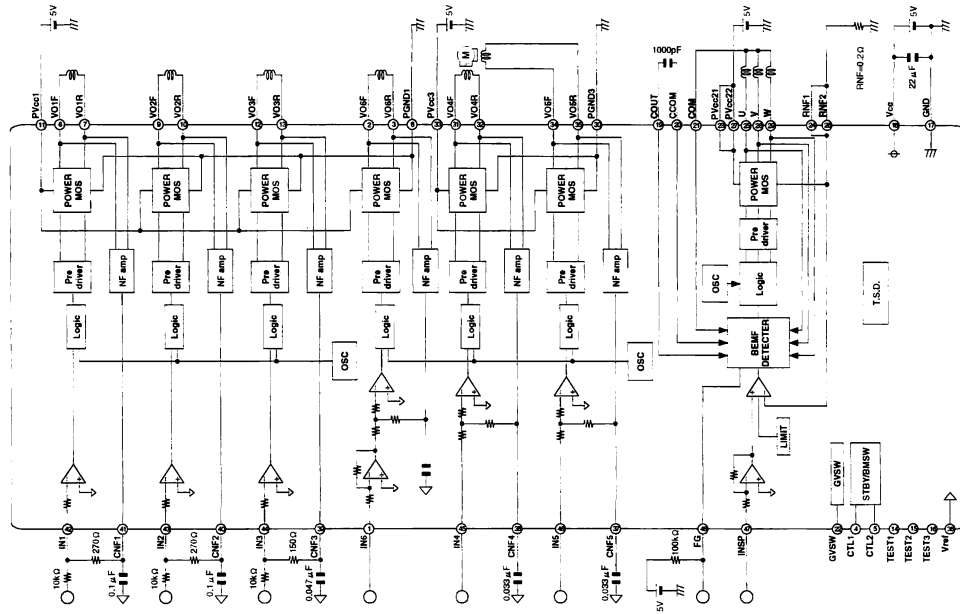

◎ PIN DESCRIPTION

Pin No.	Symbol	Description	Pin No.	Symbol	Description
1	IN2	PWM driver (CH2) input	25	COUT	Smoothing capacitor connection terminal(Output side)
2	IN3	PWM driver (CH3) input	26	CCOM	Smoothing capacitor connection terminal(COM side)
3	IN4	PWM driver (CH4) input	27	COM	Motor coil center point input terminal
4	IN5	PWM driver (CH5) input	28	GVSW	Control for gain of spindle
5	INSP	Spindle driver input	29	PVcc21	Spindle driver power supply21
6	FG	Frequency generator output	30	RNF1	Spindle driver current sense output1
7	IN6	PWM Driver (CH6) input	31	U	Spindle driver output U
8	VO6F	PWM Driver(CH6) positive output	32	V	Spindle driver output V
9	VO6R	PWM Driver(CH6) negative output	33	PVcc22	Spindle driver power supply22
10	CTL1	Driver logic control input1	34	RNF2	Spindle driver current sense output2
11	CTL2	Driver logic control input2	35	W	Spindle driver output W
12	VO1F	PWM Driver(CH1) positive output	36	PGND3	PWM driver power ground3
13	VO1R	PWM Driver(CH1) negative output	37	VO4F	PWM Driver(CH4) positive output
14	PGND1	PWM driver power ground1	38	VO4R	PWM Driver(CH4) negative output
15	VO2F	PWM Driver(CH2) positive output	39	PVcc3	PWM driver power supply3
16	VO2R	PWM Driver(CH2) negative output	40	VO5F	PWM Driver(CH5) positive output
17	PVcc1	PWM driver power supply1	41	VO5R	PWM Driver(CH5) negative output
18	VO3F	PWM Driver(CH3) positive output	42	Vref	Reference voltage input
19	VO3R	PWM Driver(CH3) negative output	43	CNF5	PWM driver (CH5) feedback filter
20	TEST1	Test terminal1	44	CNF4	PWM driver (CH4) feedback filter
21	TEST2	Test terminal2	45	CNF3	PWM driver (CH3) feedback filter
22	TEST3	Test terminal3	46	CNF2	PWM driver (CH2) feedback filter
23	GND	Pre unit ground	47	CNF1	PWM driver (CH1) feedback filter
24	Vcc	Pre unit power supply	48	IN1	PWM driver (CH1) input

Positive/Negative of the output terminals are determined in reference to those of the input terminals.

●Cautions on use

1. Absolute maximum ratings
This IC might be destroyed when the absolute maximum ratings, such as impressed voltage (PVcc, Vcc) or the operating temperature range (Topr), is exceeded, and whether the destruction is short circuit mode or open circuit mode cannot be specified. Please take into consideration the physical countermeasures for safety, such as fusing, if a particular mode that exceeds the absolute maximum rating is assumed.
2. Reverse polarity connection
Connecting the power line to the IC in reverse polarity (from that recommended) will damage the part. Please utilize the direction protection device as a diode in the supply line.
3. GND line
The ground line is where the lowest potential and transient voltages are connected to the IC.
4. Thermal design
Do not exceed the power dissipation (Pd) of the package specification rating under actual operation, and please design enough temperature margins.
5. Short circuit mode between terminals and wrong mounting
Do not mount the IC in the wrong direction and be careful about the reverse-connection of the power connector. Moreover, this IC might be destroyed when the dust short the terminals between them or GND.
6. Radiation
Strong electromagnetic radiation can cause operation failures.
7. ASO (Area of Safety Operation)
When using the IC, set the output transistor so that it does not exceed absolute maximum ratings or ASO.
8. TSD (Thermal Shut-Down)
The TSD is activated when the junction temperature (Tj) reaches 175°C (with +/-25°C hysteresis), and the output terminal is switched to Hi-z. The TSD circuit designed to shut the IC off to prevent runaway thermal operation. It is not designed to protect or guarantee its operation. Do not continue to use the IC after operating this circuit.
9. Vcc, GND and RNF wiring layout
Vcc, GND and RNF layout should be as wide as possible and at minimum distance. Wire to ground to prevent Vcc-PVcc and GND-PGND-GND side of RNF resistor from having common impedance. Connect a capacitor between Vcc and GND to stabilize.
10. Regarding input pin of the IC
This monolithic IC contains P+ isolation and P substrate layers between adjacent elements to keep them isolated. PN junctions are formed at the intersection of these P layers with the N layers of other elements, creating a parasitic diode or transistor. For example, the relation between each potential is as follows:

When GND > Pin A and GND > Pin B, the PN junction operates as a parasitic diode.
When Pin B > GND > Pin A, the PN junction operates as a parasitic transistor.

Parasitic diodes can occur inevitably in the structure of the IC. The operation of parasitic diodes can result in mutual interference among circuits, operational faults, or physical damage. Accordingly, methods by which parasitic diodes operate, such as applying a voltage that is lower than the GND (P substrate) voltage to an input pin, should not be used.

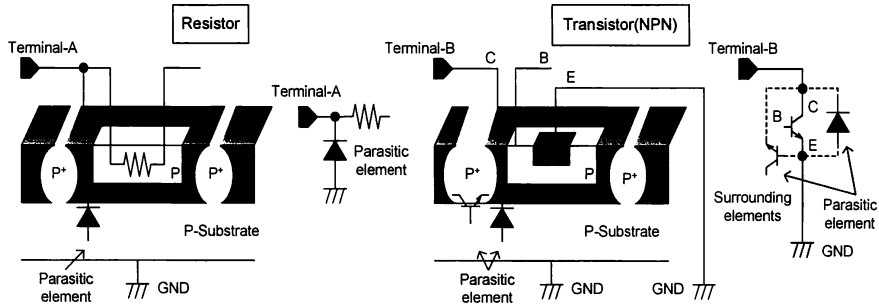

Simplified structure of IC

11. Capacitor between Vcc and GND
This IC has steep change of the voltage and current because of PWM driver. Therefore, the capacitor controls Vcc voltage by attaching a capacitor between Vcc and GND. Wiring impedance decreases the capacitors capabilities if the capacitor is far from the IC. Therefore, a capacitor should be placed between Vcc and GND, close to the IC.
12. Supply fault, ground fault and short-circuit between output terminals
Do not short-circuit between any output terminal and supply terminal (supply fault) or ground (ground fault), or between any output terminals (load short-circuit). When mounting the IC on the circuit board, be extremely cautious about the orientation of the IC. If the orientation is mistaken, the IC may break down and produce smoke in some cases.
13. Inspection by the set circuit board
When testing the IC on an application board, connecting a capacitor to a pin with low impedance subjects the IC to stress. Always discharge capacitors after each process or step. Always turn the IC's power supply off before connecting it to, or removing it from a jig or fixture, during the inspection process. Ground the IC during assembly steps as an antistatic measure. Use similar precaution when transporting and storing the IC.
14. Reverse-rotation braking
High-speed rotation may cause reverse-rotation braking. Monitor the voltage applied to the output terminal and consider the revolutions applied to the reversed-rotation brake.
15. Application circuit
It is one sample that explains standard operation and usage of this IC about the described example of the application circuit and information on the constant etc. Therefore, please be sure to consult with our sales representative in advance before mass production design, when a circuit different from application circuit is composed of external.

Notes

- No technical content pages of this document may be reproduced in any form or transmitted by any means without prior permission of ROHM CO.,LTD.
- The contents described herein are subject to change without notice. The specifications for the product described in this document are for reference only. Upon actual use, therefore, please request that specifications to be separately delivered.
- Application circuit diagrams and circuit constants contained herein are shown as examples of standard use and operation. Please pay careful attention to the peripheral conditions when designing circuits and deciding upon circuit constants in the set.
- Any data, including, but not limited to application circuit diagrams information, described herein are intended only as illustrations of such devices and not as the specifications for such devices. ROHM CO.,LTD. disclaims any warranty that any use of such devices shall be free from infringement of any third party's intellectual property rights or other proprietary rights, and further, assumes no liability of whatsoever nature in the event of any such infringement, or arising from or connected with or related to the use of such devices.
- Upon the sale of any such devices, other than for buyer's right to use such devices itself, resell or otherwise dispose of the same, no express or implied right or license to practice or commercially exploit any intellectual property rights or other proprietary rights owned or controlled by
- ROHM CO., LTD. is granted to any such buyer.
- Products listed in this document are no antiradiation design.

The products listed in this document are designed to be used with ordinary electronic equipment or devices (such as audio visual equipment, office-automation equipment, communications devices, electrical appliances and electronic toys).

Should you intend to use these products with equipment or devices which require an extremely high level of reliability and the malfunction of which would directly endanger human life (such as medical instruments, transportation equipment, aerospace machinery, nuclear-reactor controllers, fuel controllers and other safety devices), please be sure to consult with our sales representative in advance.

It is our top priority to supply products with the utmost quality and reliability. However, there is always a chance of failure due to unexpected factors. Therefore, please take into account the derating characteristics and allow for sufficient safety features, such as extra margin, anti-flammability, and fail-safe measures when designing in order to prevent possible accidents that may result in bodily harm or fire caused by component failure. ROHM cannot be held responsible for any damages arising from the use of the products under conditions out of the range of the specifications or due to non-compliance with the NOTES specified in this catalog.

Thank you for your accessing to ROHM product informations.

More detail product informations and catalogs are available, please contact your nearest sales office.

ROHM Customer Support System

THE AMERICAS / EUROPE / ASIA / JAPAN

www.rohm.com

Contact us : webmaster@rohm.co.jp