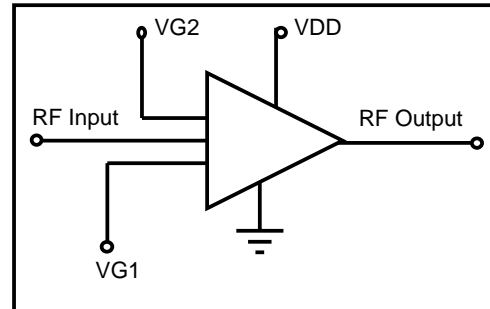

2-20GHz BROADBAND MMIC AMPLIFIER
FEATURES:

- 17 dBm Output Power
- 11 dB Gain
- pHEMT Technology
- Input Return Loss < -13dB
- Output Return Loss < -11dB
- Voltage Gain Control

FUNCTIONAL SCHEMATIC:

GENERAL DESCRIPTION:

The FMA3007 is a high performance 2-20GHz Gallium Arsenide monolithic travelling wave amplifier. It is suitable for use in broadband communication, instrumentation and electronic warfare applications. The die is fabricated using the Filtronic 0.25µm process.

TYPICAL APPLICATIONS:

- Test Instrumentation
- Electronic Warfare
- Broadband Communication Infrastructure

ELECTRICAL SPECIFICATIONS:

PARAMETER	CONDITIONS ^{1, 2, 3}	MIN	TYP	MAX	UNITS
Small Signal Gain	2-12GHz	9.5	10.5	11.5	dB
Small Signal Gain	12-20GHz	9.5	11.5	12.5	dB
Input Return Loss	2-20GHz	-	-	-13	dB
Output Return Loss	2-20GHz	-	-	-11	dB
Reverse Isolation	2-20GHz	-	-	-27	dB
Output Power at 1dB compression point	2GHz	16	19	-	dBm
	10GHz	18	19	-	dBm
	20GHz	14	16	-	dBm
Noise Figure	2-4.5 GHz	-	-	8.5	dB
Noise Figure	4.5-20 GHz	-	4.5	5.5	dB
Drain Current	For Vdd = 3.5V , Vg1 = -0.38V , Vg2 = +1V	60	100	150	mA
Drain Voltage		-	3.5	-	V

Notes:

1. T_{Ambient} = +25°C
2. Device is biased at constant gate voltage, measured on wafer with Z₀ = 50Ω
3. Measurement Conditions VG1= -0.38V, VDD= 3.5V, VG2=+1V.

ABSOLUTE MAXIMUM RATINGS:

PARAMETER	SYMBOL	ABSOLUTE MAXIMUM
Max Input Power	Pin	+20dBm
Gate Voltage	VG1	-2V
Drain Voltage	VDD	+10V
Total Power Dissipation	Ptot	tbd
Gain Compression	Comp	tbd
Thermal Resistivity	θ_{JC}	38°C/W
Operating Temp	Toper	-40°C to +85°C
Storage Temp	Tstor	-55°C to +150°C

Note: Exceeding any one of these absolute maximum ratings may cause permanent damage to the device.

PAD REF	PAD NAME	DESCRIPTION	PIN COORDINATES (μm)
A	RF in	RF in	(140, 1153)
B	VDP	(+Ve) Temperature Monitoring Diode	(2097, 140)
C	VDN	(-Ve) Temperature Monitoring Diode	(2321, 140)
D	GND	Ground	(2545, 140)
E	VG1	Gate Control	(2769, 140)
F	VG2	Gain Control	(2993, 140)
G	RF Out	RF Out	(3004, 1141)
H	GND	Ground	(2800, 1650)
I	VDD	Drain Voltage	(2550, 1650)

Note: Co-ordinates are referenced from the bottom left hand corner of the die to the centre of bond pad opening

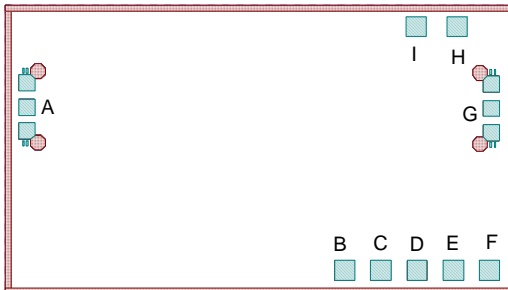
PAD LAYOUT:

DIE SIZE (μm)	DIE THICKNESS (μm)	MIN. BOND PAD PITCH (μm)	MIN. BOND PAD OPENING ($\mu\text{m} \times \mu\text{m}$)
3150 x 1780	100	220	100 x 100

TYPICAL PERFORMANCE FOR ON WAFER MEASUREMENTS:

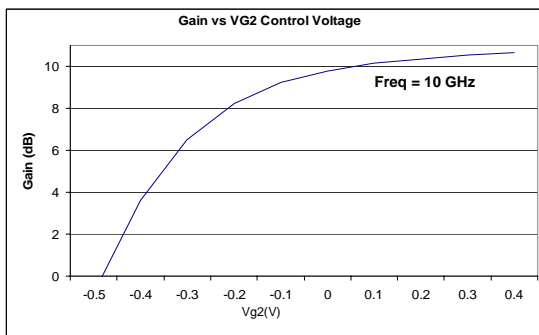
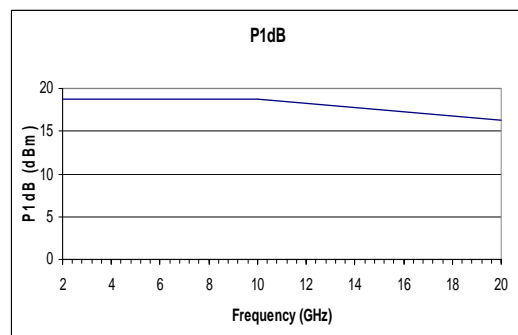
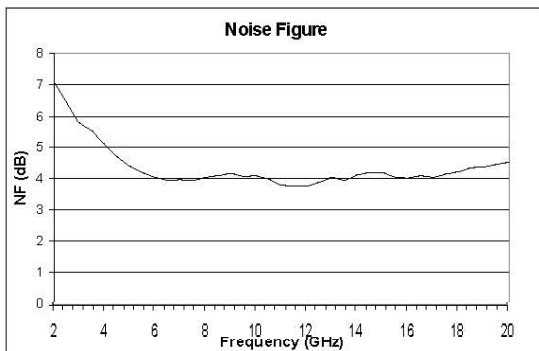
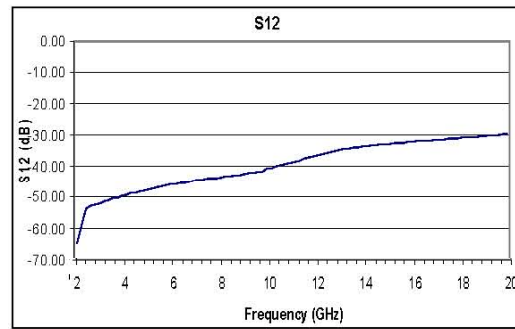
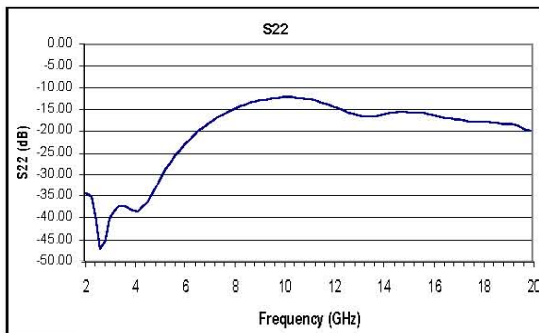
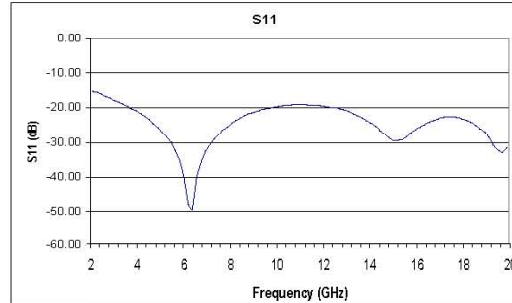
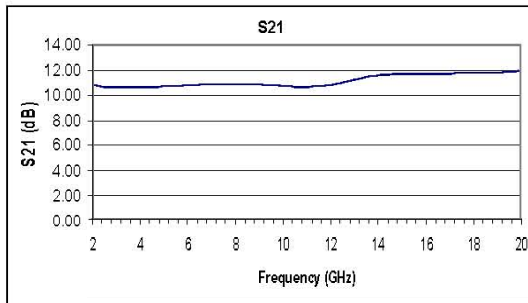
 Note: Measurement Conditions $V_{G1} = -0.38V$, $V_{DD} = 3.5V$, $V_{G2} = +1V$, $T_{AMBIENT} = 25^{\circ}C$

TYPICAL MEASURED PERFORMANCE FOR ON WAFER TEMPERATURE MEASUREMENTS:

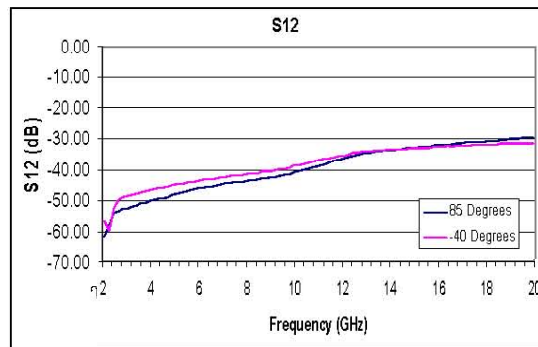
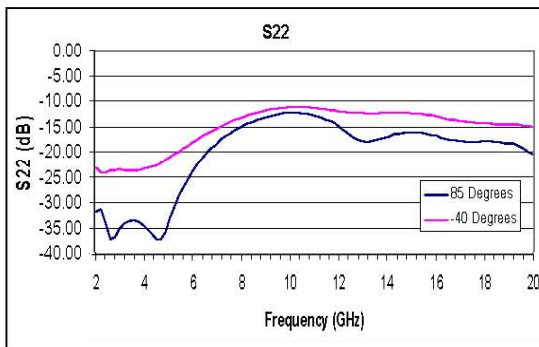
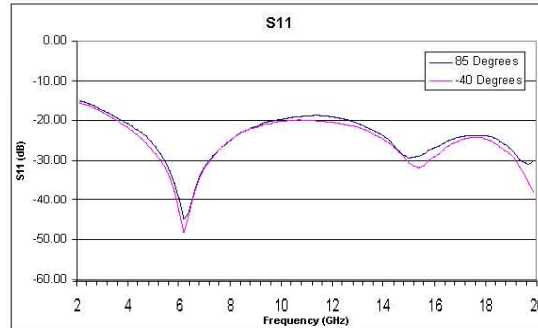
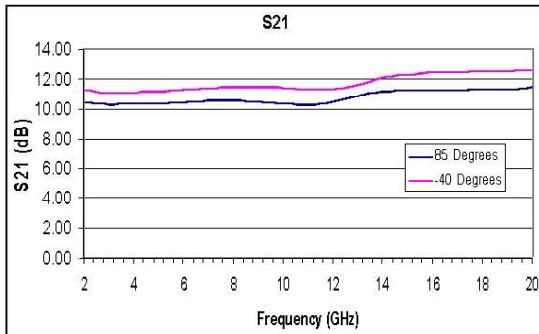
 Note: Measurement Conditions $V_{G1} = -0.38V$, $V_{DD} = 3.5V$, $V_{G2} = +1V$, $T_{AMBIENT} = -40^{\circ}C$ to $+85^{\circ}C$

S-PARAMETERS FOR ON-WAFER MEASUREMENTS:

Note: Measurement Conditions VDD= 3.5V, Vg1=-0.38V and Vg2=1V

Frequency	S11		S21		S12		S22	
	Mag	Angle	Mag	Angle	Mag	Angle	Mag	Angle
2	0.17	7.23	3.47	-36.35	0.00	-63.41	0.02	-48.45
2.19	0.17	2.14	3.45	-42.93	0.00	-29.52	0.02	-37.80
2.38	0.16	-4.69	3.43	-48.73	0.00	72.59	0.01	-33.00
2.57	0.15	-10.51	3.42	-54.29	0.00	42.47	0.00	27.64
2.76	0.14	-15.56	3.42	-59.82	0.00	27.49	0.01	-38.27
2.95	0.13	-20.19	3.42	-65.28	0.00	13.11	0.01	-44.59
3.14	0.12	-24.56	3.42	-70.67	0.00	4.32	0.01	21.28
3.33	0.11	-28.52	3.42	-75.97	0.00	-3.76	0.01	15.31
3.52	0.11	-32.28	3.42	-81.24	0.00	-11.28	0.01	13.40
3.71	0.10	-36.00	3.41	-86.45	0.00	-17.93	0.01	13.67
3.9	0.09	-39.67	3.42	88.39	0.00	-24.95	0.01	-16.72
4.09	0.08	-43.21	3.42	83.29	0.00	-30.94	0.01	-6.18
4.28	0.08	-46.86	3.42	78.22	0.00	-40.08	0.01	-65.06
4.47	0.07	-50.51	3.42	73.16	0.00	-45.92	0.02	-53.62
4.66	0.06	-53.98	3.43	68.10	0.00	-50.32	0.02	-44.57
4.85	0.05	-57.63	3.43	63.07	0.00	-56.49	0.02	-39.29
5.04	0.05	-60.76	3.44	58.02	0.00	-63.05	0.03	-37.33
5.23	0.04	-63.54	3.44	52.99	0.00	-67.95	0.04	-37.85
5.42	0.03	-66.22	3.45	47.95	0.00	-74.11	0.04	-39.95
5.61	0.02	-68.53	3.46	42.91	0.00	-79.14	0.05	-42.71
5.8	0.02	-68.00	3.47	37.87	0.00	-83.92	0.06	-45.73
5.99	0.01	-64.51	3.48	32.78	0.01	18.48	0.07	-49.38
6.18	0.00	-42.62	3.48	27.71	0.01	84.14	0.08	-53.42
6.37	0.00	39.78	3.49	22.64	0.01	80.03	0.09	-57.88
6.56	0.01	17.49	3.50	17.55	0.01	73.81	0.10	-62.71
6.75	0.02	16.81	3.51	12.44	0.01	68.78	0.11	-67.57
6.94	0.02	15.13	3.51	7.30	0.01	64.80	0.12	-72.36
7.13	0.03	84.08	3.52	2.14	0.01	60.68	0.13	-77.27
7.32	0.04	82.14	3.52	-3.01	0.01	55.34	0.14	-82.39
7.51	0.04	79.53	3.52	-8.15	0.01	49.63	0.15	-51.70
7.7	0.05	76.81	3.53	-13.28	0.01	47.53	0.16	87.01
7.89	0.05	74.57	3.53	-18.47	0.01	41.87	0.17	81.73
8.08	0.06	72.42	3.52	-23.66	0.01	38.81	0.18	76.45
8.27	0.07	69.51	3.52	-28.79	0.01	35.08	0.19	71.34
8.46	0.07	66.45	3.51	-33.90	0.01	30.21	0.20	65.86
8.65	0.08	64.01	3.51	-39.00	0.01	27.00	0.21	60.25
8.84	0.08	60.83	3.51	-44.12	0.01	21.43	0.22	54.28
9.03	0.09	58.56	3.50	-49.28	0.01	17.73	0.22	48.57
9.22	0.09	55.69	3.49	-54.36	0.01	16.35	0.23	42.85
9.41	0.09	52.28	3.48	-59.39	0.01	11.43	0.23	36.83
9.6	0.10	48.64	3.47	-64.39	0.01	8.25	0.24	30.81
9.79	0.10	45.29	3.46	-69.39	0.01	4.95	0.24	24.23
9.98	0.10	41.97	3.45	-74.39	0.01	2.14	0.24	17.61
10.17	0.11	38.97	3.45	-79.32	0.01	-1.56	0.24	10.75
10.36	0.11	36.22	3.44	-84.20	0.01	-5.54	0.24	3.94
10.55	0.11	33.38	3.43	-17.05	0.01	-10.51	0.24	-3.27
10.74	0.11	30.10	3.43	86.12	0.01	-14.21	0.24	-10.81
10.93	0.11	26.91	3.43	81.37	0.01	-19.00	0.24	-18.81

S-PARAMETERS CONTINUED

Frequency	S11		S21		S12		S22	
	Mag	Angle	Mag	Angle	Mag	Angle	Mag	Angle
11.12	0.11	22.84	3.43	76.53	0.01	-22.37	0.23	-27.22
11.31	0.11	19.06	3.43	71.78	0.01	-27.33	0.22	-36.26
11.5	0.11	14.69	3.44	67.04	0.01	-31.55	0.21	-45.16
11.69	0.11	9.79	3.45	62.28	0.01	-37.22	0.21	-55.08
11.88	0.11	6.23	3.47	57.43	0.01	-42.25	0.20	-65.94
12.07	0.11	1.32	3.49	52.51	0.01	-48.26	0.19	-77.17
12.26	0.10	-2.75	3.52	47.60	0.02	-52.88	0.18	-17.48
12.45	0.10	-7.08	3.54	42.70	0.02	-57.45	0.17	77.51
12.64	0.10	-11.05	3.58	37.72	0.02	-64.77	0.16	63.15
12.83	0.10	-15.83	3.62	32.50	0.02	-71.06	0.16	48.80
13.02	0.09	-20.74	3.65	27.22	0.02	-76.93	0.15	33.57
13.21	0.09	-26.37	3.68	21.86	0.02	-82.74	0.15	17.88
13.4	0.08	-33.12	3.72	16.46	0.02	-16.85	0.15	1.73
13.59	0.08	-39.86	3.75	11.01	0.02	85.12	0.15	-13.77
13.78	0.07	-46.40	3.78	5.41	0.02	79.01	0.15	-28.48
13.97	0.07	-54.81	3.80	-0.34	0.02	73.33	0.15	-41.98
14.16	0.06	-64.08	3.81	-6.03	0.02	68.29	0.16	-54.27
14.35	0.05	-72.76	3.82	-11.60	0.02	62.69	0.16	-65.54
14.54	0.05	-81.47	3.84	-17.22	0.02	57.29	0.16	-76.15
14.73	0.04	-90.91	3.85	-22.91	0.02	51.71	0.17	-87.08
14.92	0.04	-101.00	3.85	-28.64	0.02	46.06	0.17	-98.24
15.11	0.03	-111.20	3.84	-34.30	0.02	40.76	0.16	-109.52
15.3	0.03	-121.02	3.84	-39.83	0.02	34.90	0.16	-120.96
15.49	0.04	-130.93	3.85	-45.39	0.02	29.64	0.16	-132.48
15.68	0.04	-140.28	3.85	-51.01	0.02	24.41	0.16	-144.00
15.87	0.04	-149.94	3.85	-56.69	0.02	19.88	0.16	-155.54
16.06	0.05	-159.60	3.85	-62.28	0.02	14.12	0.15	-167.00
16.25	0.05	-169.49	3.85	-67.91	0.03	8.67	0.15	-178.40
16.44	0.06	-179.22	3.86	-73.44	0.03	3.54	0.14	-189.70
16.63	0.06	-188.98	3.87	-79.17	0.03	-3.05	0.14	-200.90
16.82	0.07	-198.00	3.87	-84.87	0.03	-7.81	0.14	-212.00
17.01	0.07	-207.62	3.87	-90.55	0.03	-13.42	0.14	-223.00
17.2	0.07	-217.90	3.87	-96.22	0.03	-18.83	0.13	-233.90
17.39	0.07	-228.35	3.87	-101.89	0.03	-24.46	0.13	-244.70
17.58	0.07	-238.44	3.88	-107.52	0.03	-29.63	0.13	-255.40
17.77	0.07	-248.96	3.89	-113.11	0.03	-35.63	0.13	-266.00
17.96	0.07	-259.63	3.89	-118.66	0.03	-40.03	0.13	-276.50
18.15	0.07	-270.97	3.89	-124.17	0.03	-46.04	0.13	-286.90
18.34	0.07	-282.45	3.89	-129.64	0.03	-51.04	0.13	-297.20
18.53	0.06	-294.09	3.90	-135.07	0.03	-56.89	0.12	-307.40
18.72	0.06	-305.89	3.90	-140.46	0.03	-61.73	0.12	-317.50
18.91	0.05	-317.88	3.90	-145.81	0.03	-67.11	0.12	-327.50
19.1	0.04	-330.00	3.91	-151.12	0.03	-72.52	0.12	-337.40
19.29	0.04	-342.44	3.91	-156.39	0.03	-78.57	0.12	-347.20
19.48	0.03	-355.00	3.92	-161.62	0.03	-84.34	0.12	-356.90
19.67	0.02	-367.66	3.93	-166.81	0.03	-89.99	0.11	-366.50
19.86	0.02	-380.44	3.95	-171.96	0.03	-84.17	0.10	-376.00
20	0.03	-400.00	3.96	-177.07	0.03	78.45	0.10	-385.50

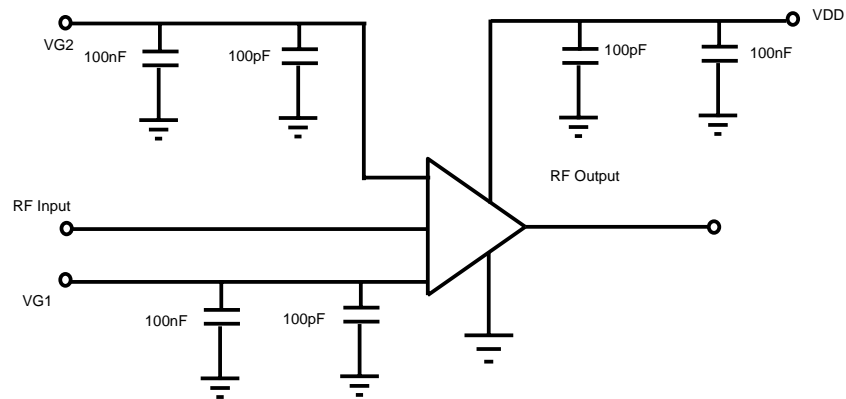
BIASING CIRCUIT SCHEMATIC:

ASSEMBLY DIAGRAM:

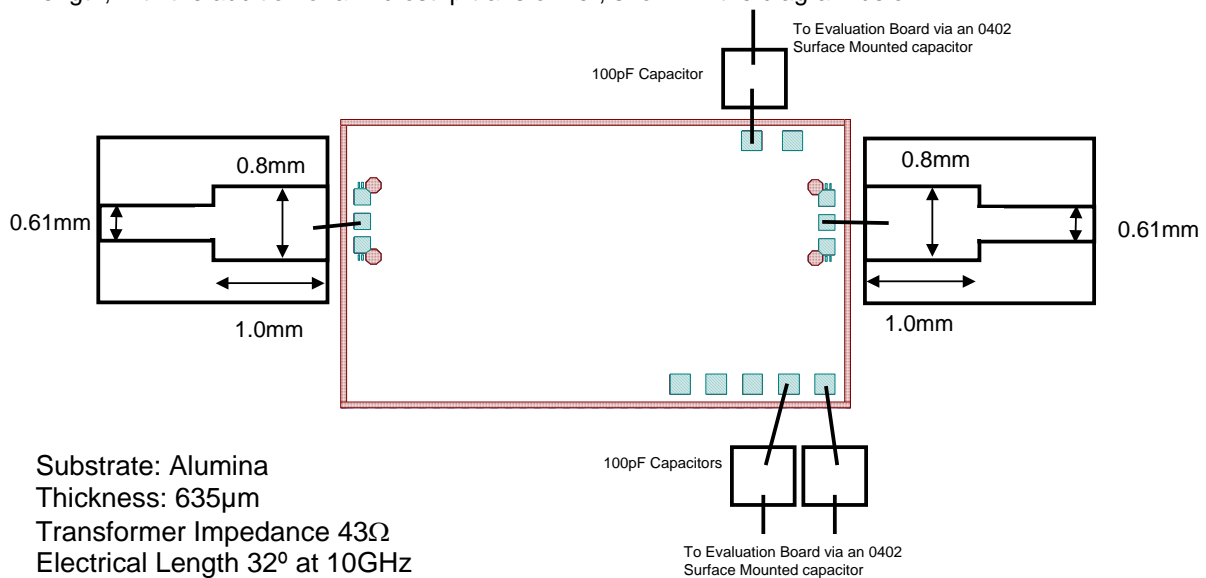
It is recommended that the RF connections be made using two bond wires 25 μ m in diameter and a maximum length of 300 μ m. Improved input return loss can be achieved, to compensate for bond wire length, with the addition of a microstrip transformer, shown in the diagram below.

BILL OF MATERIALS:

COMPONENT
All RF tracks should be 50 Ω characteristic material
Capacitor, 100pF, chip capacitor
Capacitor, 100pF, 0402

PREFERRED ASSEMBLY INSTRUCTIONS:

GaAs devices are fragile and should be handled with great care. Specially designed collets should be used where possible.

The recommended die attach is gold/tin eutectic solder under a nitrogen atmosphere. Stage temperature should be 280-290°C; maximum time at temperature is one minute. The recommended wire bond method is thermo-compression wedge bonding with 0.7 or 1.0 mil (0.018 or 0.025 mm) gold wire. Stage temperature should be 250-260°C.

Bonds should be made from the die first and then to the mounting substrate or package. The physical length of the bondwires should be minimised especially when making RF or ground connections.

ORDERING INFORMATION:

PART NUMBER	DESCRIPTION
FMA3007	Die in Waffle-pack (Gel-pak available on request)

**HANDLING
PRECAUTIONS:**

To avoid damage to the devices care should be exercised during handling. Proper Electrostatic Discharge (ESD) precautions should be observed at all stages of storage, handling, assembly, and testing. These devices should be treated as Class 0 (0-250 V) as defined in JEDEC Standard No. 22-A114. Further information on ESD control measures can be found in MIL-STD-1686 and MIL-HDBK-263.

APPLICATION NOTES & DESIGN DATA:

Application Notes and design data including S-parameters, noise data are available on request.

DISCLAIMERS:

This product is not designed for use in any space based or life sustaining/supporting equipment.