

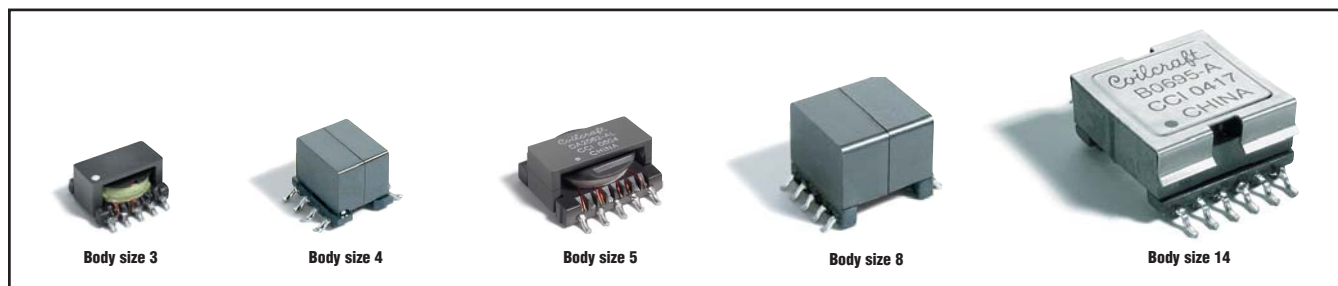

# Flyback Transformers

For complete specifications see [www.coilcraft.com](http://www.coilcraft.com)



This list of dc-dc and off-line switching converter transformers are stocked for immediate delivery and may be sampled at no cost. They are organized by input and sorted by output. These transformers also operate well in applications with power levels other than those shown and at a wide range of frequencies. The nominal frequency and circuit reference are only provided as a guide.

A selection of flyback transformers designed as capacitor chargers are shown at the top of page 4.

If no transformer shown here meets your design criteria, consult Document 627 "Coilcraft Structured Design Guide for Switching Transformers" for a step-by-step guide to transformer design, or contact Coilcraft for assistance.

Part number	Power (W)	Output	Aux / bias	Nominal freq. (kHz)	Turns ratio		L at 0 A ( $\mu$ H)	DCR (Ohms)			Schem	Body size	Mtg	Designed for
					pri : sec	pri : aux / bias		pri	sec	aux / bias				
<b>Telecom input (36 – 72 Vdc)</b>														
B0226-EL	2.0	12 V, 167 mA 12 V, 3 mA	—	1000	1 : 0.36 1 : 0.36	—	120	0.364	0.248 0.248	—	B	2	SM	On Semi NCP1030
POE30P-33L	3.0	3.3 V, 0.91 A	12 V, 20 mA	250	1 : 0.19	1 : 0.70	310	1.02	2.01	0.066	D	4	SM	PoE
C1590-AL	3.0	3.3 V, 0.91 A	12 V, 20 mA	250	1 : 0.19	1 : 0.70	310	1.02	2.01	0.066	D	4	SM	NSC LM5070
POE30P-50L	3.0	5.0 V, 0.6 A	12 V, 20 mA	250	1 : 0.28	1 : 0.70	310	1.02	2.01	0.118	D	4	SM	PoE
C1591-AL	3.0	5.0 V, 0.6 A	12 V, 20 mA	250	1 : 0.28	1 : 0.70	310	1.02	2.01	0.118	D	4	SM	NSC LM5070
POE30P-12L	3.0	12 V, 0.25 A	12 V, 20 mA	250	1 : 0.70	1 : 0.70	310	1.04	2.01	0.70	D	4	SM	PoE
C1592-AL	3.0	12 V, 0.25 A	12 V, 20 mA	250	1 : 0.70	1 : 0.70	310	1.04	2.01	0.70	D	4	SM	NSC LM5070
POE60F-18L	6.0	1.8 V, 3.3 A	12 V, 20 mA	250	1 : 0.07	1 : 0.36	75	0.195	0.005	0.195	D	9	SM	PoE
POE60C-18L	6.0	1.8 V, 3.3 A	12 V, 20 mA	250	1 : 0.063	1 : 0.344	167	0.303	0.017	0.57	D	6	SM	PoE
POE60D-18L	6.0	1.8 V, 3.3 A	12 V, 20 mA	250	1 : 0.063	1 : 0.344	75	0.311	0.018	0.575	D	6	SM	PoE
POE60F-25L	6.0	2.5 V, 2.4 A	12 V, 20 mA	250	1 : 0.08	1 : 0.33	55	0.095	0.005	0.15	D	9	SM	PoE
POE60C-25L	6.0	2.5 V, 2.4 A	12 V, 20 mA	250	1 : 0.083	1 : 0.333	177	0.353	0.027	0.66	D	6	SM	PoE
POE60D-25L	6.0	2.5 V, 2.4 A	12 V, 20 mA	250	1 : 0.083	1 : 0.333	80	0.219	0.017	0.388	D	6	SM	PoE
POE60F-33L	6.0	3.3 V, 1.8 A	12 V, 20 mA	250	1 : 0.11	1 : 0.36	65	0.138	0.007	0.18	D	9	SM	PoE
POE60C-33L	6.0	3.3 V, 1.8 A	12 V, 20 mA	250	1 : 0.100	1 : 0.333	184	0.286	0.026	0.515	D	6	SM	PoE
POE60D-33L	6.0	3.3 V, 1.8 A	12 V, 20 mA	250	1 : 0.100	1 : 0.333	85	0.285	0.026	0.53	D	6	SM	PoE
POE60F-50L	6.0	5.0 V, 1.2 A	12 V, 20 mA	250	1 : 0.15	1 : 0.35	60	0.130	0.009	0.165	D	9	SM	PoE
POE60C-50L	6.0	5.0 V, 1.2 A	12 V, 20 mA	250	1 : 0.143	1 : 0.343	193	0.344	0.043	0.66	D	6	SM	PoE
POE60D-50L	6.0	5.0 V, 1.2 A	12 V, 20 mA	250	1 : 0.143	1 : 0.357	90	0.271	0.033	0.529	D	6	SM	PoE
POE60F-12L	6.0	12 V, 0.5 A	12 V, 20 mA	250	1 : 0.35	1 : 0.35	55	0.095	0.017	0.15	D	9	SM	PoE
POE60C-12L	6.0	12.0 V, 0.5 A	12 V, 20 mA	250	1 : 0.333	1 : 0.333	204	0.293	0.083	0.545	D	6	SM	PoE
POE60D-12L	6.0	12.0 V, 0.5 A	12 V, 20 mA	250	1 : 0.333	1 : 0.333	95	0.265	0.074	0.484	D	6	SM	PoE
A0009-AL	6.6	3.3 V, 3 A	24 V	100	1 : 0.333	1 : 1	100	0.15	0.15	0.012	D	13	SM	NSC LM5000
POE70P-33L	7.0	3.3 V, 2.12 A	12 V, 20 mA	250	1 : 0.19	1 : 0.667	155	0.414	0.822	0.036	D	7	SM	PoE
C1587-AL	7.0	3.3 V, 2.12 A	12 V, 20 mA	10	1 : 0.19	1 : 0.667	155	0.414	0.822	0.036	D	7	SM	NSC LM5070
POE70P-50L	7.0	5.0 V, 1.4 A	12 V, 20 mA	250	1 : 0.262	1 : 0.667	155	0.414	0.822	0.06	D	7	SM	PoE
C1588-AL	7.0	5.0 V, 1.4 A	12 V, 20 mA	10	1 : 0.262	1 : 0.667	155	0.414	0.822	0.06	D	7	SM	NSC LM5070
POE70P-12L	7.0	12 V, 0.6 A	12 V, 20 mA	250	1 : 0.667	1 : 0.667	155	0.414	0.822	0.343	D	7	SM	PoE
C1589-AL	7.0	12 V, 0.6 A	12 V, 20 mA	10	1 : 0.667	1 : 0.667	155	0.414	0.822	0.343	D	7	SM	NSC LM5070
D1766-AL	10	3.3 V, 5 A 2.5 V, 1.5 A 1.8 V, 2.5 A	—	200	1 : 0.104 1 : 0.042 1 : 0.042	—	221	0.420	0.065 0.015 0.030	—	C	14	SM	Linear LTC4267
C1048-AL	10	5 V, 2 A	15 V, 0.2 A	250	1 : 0.12	1 : 0.47	94	0.210	0.010	0.453	D	9	SM	Linear LT1725
FA2519-AL	11	3.3 V, 3.3 A	10 V, 20 mA	250	1 : 0.20	1 : 0.60	55	0.026	0.026	0.388	D	14	SM	NSC LM5071, LM5072
POE13F-18L	13	1.8 V, 7.2 A	12 V, 20 mA	250	1 : 0.07	1 : 0.36	45	0.195	0.005	0.195	D	9	SM	PoE

**Coilcraft**<sup>®</sup>

Specification subject to change without notice.  
Please check our website for latest information.

Document 651-1 Revised 02/01/10

1102 Silver Lake Road Cary, Illinois 60013 Phone 847/639-6400 Fax 847/639-1469  
E-mail [info@coilcraft.com](mailto:info@coilcraft.com) Web <http://www.coilcraft.com>



# Flyback Transformers

Part number	Power (W)	Output	Aux / bias	Nominal freq. (kHz)	Turns ratio		L at 0 A (µH)	DCR (Ohms)			Schem	Body size	Mtg	Designed for
					pri : sec	pri : aux / bias		pri	sec	aux / bias				
<b>Telecom input (36 – 72 Vdc) continued</b>														
POE13F-25L	13	2.5 V, 5.2 A	12 V, 20 mA	250	1 : 0.08	1 : 0.33	35	0.095	0.005	0.150	D	9	SM	PoE
POE13F-33L	13	3.3 V, 3.9 A	12 V, 20 mA	250	1 : 0.11	1 : 0.36	40	0.138	0.007	0.180	D	9	SM	PoE
POE13P-33L	13	3.3 V, 4.0 A	12 V, 20 mA	250	1 : 0.166	1 : 0.50	127	0.255	0.310	0.024	D	8	SM	PoE
POE13F-50L	13	5.0 V, 2.6 A	12 V, 20 mA	250	1 : 0.15	1 : 0.35	40	0.130	0.009	0.165	D	9	SM	PoE
POE13P-50L	13	5.0 V, 2.6 A	12 V, 20 mA	250	1 : 0.25	1 : 0.50	127	0.222	0.348	0.039	D	8	SM	PoE
DA2362-AL	13	5.0 V, 2.6 A	12 V, 20 mA	250	1 : 0.25	1 : 0.594	127	0.222	0.039	0.405	D	8	SM	Freescale MC34670
GA3372-AL	13	5.0 V, 2.6 A	10 V, 20 mA	250	1 : 0.25	1 : 0.50	102	0.185	0.0175	0.270	D	8	SM	NSC LM5015
POE13F-12L	13	12 V, 1.1 A	12 V, 20 mA	250	1 : 0.35	1 : 0.35	35	0.095	0.017	0.150	D	9	SM	PoE
POE13P-12L	13	12 V, 1.08 A	12 V, 20 mA	250	1 : 0.50	1 : 0.50	127	0.199	0.308	0.065	D	8	SM	PoE
POE13F-19L	13	19.5 V, 0.67 A	12 V, 20 mA	250	1 : 0.57	1 : 0.35	37	0.085	0.025	0.385	D	9	SM	PoE
POE13P-19L	13	19.5 V, 0.67 A	12 V, 20 mA	250	1 : 0.567	1 : 0.50	127	0.290	0.355	0.066	D	8	SM	PoE
POE13F-24L	13	24 V, 0.54 A	12 V, 20 mA	250	1 : 0.67	1 : 0.33	37	0.086	0.049	0.370	D	9	SM	PoE
POE13P-24L	13	24 V, 0.54 A	12 V, 20 mA	250	1 : 0.667	1 : 0.50	127	0.255	0.315	0.067	D	8	SM	PoE
B0695-AL	15	3.3 V, 4.5 A	12 V	10	1 : 0.23	1 : 0.69	110	0.133	0.004	0.656	D	14	SM	NSC LM5020
C1023-AL	15	3.3 V, 4.5 A	24 V	10	1 : 0.19	1 : 0.69	110	0.139	0.005	0.656	D	14	SM	NSC LM5070
POE300F-33L	30	3.3 V, 9 A	19.5 V, 1.5 A	250	1 : 0.09	1 : 0.33	42	0.060	0.037	0.195	D	14	SM	PoE plus
POE300F-50L	30	5.0 V, 6 A	24 V, 1.25 A	250	1 : 0.14	1 : 0.33	42	0.060	0.055	0.195	D	14	SM	PoE plus
POE300F-12L	30	12 V, 2.5 A	3.3 V, 9 A	250	1 : 0.33	1 : 0.33	42	0.070	0.0023	0.220	D	14	SM	PoE plus
POE300F-19L	30	19.5 V, 1.5 A	5 V, 6 A	250	1 : 0.56	1 : 0.33	42	0.069	0.005	0.225	D	14	SM	PoE plus
POE300F-24L	30	24 V, 1.25 A	12 V, 2.5 A	250	1 : 0.67	1 : 0.33	42	0.061	0.015	0.195	D	14	SM	PoE plus
<b>Telecom input (36 – 57 Vdc)</b>														
C1453-AL	5.0	3.3 V, 1.5 A	10 V	1000	1 : 0.166	1 : 0.5	50	0.185	0.015	0.385	D	3	SM	Texas Instruments PMP717
DA2062-AL	6.6	3.3 V, 2 A	14 V	400	1 : 0.1	1 : 0.4	120	0.475	0.0065	0.181	E	5	SM	Power Integrations DPA423G
HA3801-AL	10	3.3 V, 3 A	10 V, 20 mA	125	1 : 0.154	1 : 0.5	166.5	0.735	0.0225	0.985	F	9	SM	TI TPS23753
FA2671-AL	10	3.3 V, 3 A	—	350	1 : 0.333	—	40	0.098	0.062	—	A	7	SM	Silicon Labs Si3400
HA3802-AL	10	5.0 V, 2 A	10 V, 20 mA	125	1 : 0.2	1 : 0.444	150	0.52	0.0275	0.770	F	9	SM	TI TPS23753
FA2672-AL	10	5.0 V, 2 A	—	350	1 : 0.25	—	40	0.098	0.085	—	A	7	SM	Silicon Labs Si3400
HA3803-AL	10	12 V, 0.83 A	10 V, 20 mA	125	1 : 0.5	1 : 0.5	166.5	0.76	0.101	1.10	F	9	SM	TI TPS23753
FA2732-AL	10	12 V, 0.83 A	—	350	1 : 1	—	40	0.098	0.156	—	A	7	SM	Silicon Labs Si3400
HA3905-CL	12.5	5 V, 2.5 A	12 V, 20 mA	250	1 : 0.267	1 : 0.735	27	0.71	0.015	0.385	J	8	SM	Microsemi UC3844
GA3271-AL	13	10 V, 1.0 A	15 V, 20 mA	275	1 : 0.457	1 : 0.571	117.5	0.201	0.06	0.335	D	9	SM	Maxim MAX5941B
C1495-AL	13	3.3 V, 4.0 A	12 V, 20 mA	250	1 : 0.166	1 : 0.50	127	0.255	0.31	0.024	D	8	SM	NSC LM5070
C1585-AL	13	5.0 V, 2.6 A	12 V, 20 mA	250	1 : 0.25	1 : 0.50	127	0.222	0.348	0.039	D	8	SM	NSC LM5070
C1586-AL	13	12 V, 1.08 A	12 V, 20 mA	250	1 : 0.50	1 : 0.50	127	0.199	0.308	0.065	D	8	SM	NSC LM5070
FA2805-CL	15	5.0 V, 3 A	—	350	1 : 0.40	—	40	0.108	0.04	—	A	8	SM	Silicon Labs Si3400/3401
FA2924-AL	15	3.3 V, 4.5 A	—	350	1 : 0.31	—	40	0.1	0.025	—	A	8	SM	Silicon Labs Si3400/3401
FA2925-AL	15	12 V, 1.25 A	—	350	1 : 1	—	40	0.1	0.155	—	A	8	SM	Silicon Labs Si3400/3401
FA2706-BL	20	3.3 V, 6 A	10 V	250	1 : 0.147	1 : 0.412	77.8	0.155	0.008	0.382	F	11	SM	STMicro PM8800
FA2707-BL	20	5 V, 4 A	10 V	250	1 : 0.206	1 : 0.412	77.8	0.155	0.019	0.380	F	11	SM	STMicro PM8800
<b>Telecom extended input (14 – 60 Vdc)</b>														
DA2257-AL	11.6	3.3 V, 2 A 5.0 V, 1 A	10 V, 50 mA	250	1 : 0.167 1 : 0.28	1 : 0.5	35	0.062	0.010 0.018	0.225	H	8	SM	NSC LM5071
<b>Telecom extended input (16 – 32 Vdc)</b>														
FA2636-AL	5.0	5.0 V, 1 A	7.5 V	250	1 : 0.25	1 : 0.38	160	0.225	0.340	0.078	D	8	SM	NSC LM5001
<b>Telecom extended input (18 – 57 Vdc)</b>														
FA2677-AL	25	3.3 V, 7.5 A	11 V, 20 mA	250	1 : 0.12	1 : 0.41	50	0.260	0.0026	0.328	D	14	SM	NSC LM5072
FA2898-AL	25	5.0 V, 5 A	11 V, 20 mA	250	1 : 0.18	1 : 0.41	50	0.260	0.004	0.315	D	14	SM	NSC LM5072
FA2899-AL	25	9 V, 2.8 A	11 V, 20 mA	250	1 : 0.35	1 : 0.41	50	0.260	0.013	0.315	D	14	SM	NSC LM5072
FA2900-AL	25	12 V, 2.1 A	11 V, 20 mA	250	1 : 0.47	1 : 0.41	50	0.260	0.020	0.315	D	14	SM	NSC LM5072
FA2901-AL	25	15 V, 1.7 A	11 V, 20 mA	250	1 : 0.59	1 : 0.41	50	0.260	0.037	0.305	D	14	SM	NSC LM5072
A9967-AL	30	15 V, 2 A	1.25 V	100	1 : 0.667	1 : 0.50	10	0.015	0.0225	0.045	B	14	SM	Linear LT1725
<b>Telecom extended input (18 – 72 Vdc)</b>														
C1154-BL	2.2	3.3 V, 0.2 A 2.5 V, 0.6 A	15 V / 5 V	275	1 : 0.10 1 : 0.075	1 : 0.425	255	0.335	0.200 0.017	0.745	G	9	SM	Maxim MAX5941A
C1099-AL	8.3	3.3 V, 2.5 A	14 V	275	1 : 0.13	1 : 0.57	133	0.283	0.013	0.480	B	9	SM	Maxim MAX5941A
C1173-AL	9.9	3.3 V, 3 A	10 V / 5.6 V	500	1 : 0.15	1 : 0.5	166.5	0.770	0.020	1.120	F	9	SM	TI TPS23750
C1174-AL	10	5.0 V, 2 A	10 V / 7.5 V	500	1 : 0.20	1 : 0.44	150.0	0.515	0.023	0.880	F	9	SM	TI TPS23750
<b>Telecom extended input (24 – 60 Vdc)</b>														
DA2383-AL	13	3.3 V, 4 A	10 V, 0.05 A	250	1 : 0.16	1 : 0.50	127	0.255	0.012	0.310	D	8	SM	NSC LM5071
<b>3.3 Vdc input</b>														
DA2420-AL	1.2	12 V, 0.1 A	—	100	1 : 2	—	330	0.406	5.92	—	A	14	SM	ST Micro STE12PS
DA2421-AL	1.2	12 V, 0.1 A	—	100	1 : 3	—	330	0.442	14.145	—	A	14	SM	ST Micro STE12PS

# Coilcraft®

Specification subject to change without notice.  
Please check our website for latest information.

Document 651-2 Revised 02/01/10

1102 Silver Lake Road Cary, Illinois 60013 Phone 847/639-6400 Fax 847/639-1469

E-mail [info@coilcraft.com](mailto:info@coilcraft.com) Web <http://www.coilcraft.com>



# Flyback Transformers

Part number	Power (W)	Output	Aux / bias output	Nominal freq. (kHz)	Turns ratio		L at 0 A (µH)	DCR (Ohms)			Schem	Body size	Mtg	Designed for
					pri : sec	pri : aux / bias		pri	sec	aux / bias				
<b>4 – 6 Vdc input</b>														
S6057-AL	4.5	5.0 V / 0.9 A	—	100	1 : 1	—	47	0.065	0.065	—	A	15	SM	NSC LM258X (T7)
S6000-AL	4.5	5.0 V / 0.9 A	—	100	1 : 1	—	47	0.065	0.042	—	A	18	TH	NSC LM258X (T7)
Q4435-BL	8	5.0 V, 1.6 A	—	100	1 : 1	—	22	0.02	0.250	—	A	15	SM	NSC LM258X (T1)
Q4434-BL	8	5.0 V, 1.6 A	—	100	1 : 1	—	22	0.028	0.280	—	A	18	TH	NSC LM258X (T1)
Q4436-BL	4.2	12 V, 0.35 A -12 V, 0.35 A	—	100	1 : 2.5 1 : 2.5	—	22	0.025	0.230 0.250	—	B	15	SM	NSC LM258X (T2)
Q4337-BL	4.2	12 V, 0.35 A -12 V, 0.35 A	—	100	1 : 2.5 1 : 2.5	—	22	0.03	0.320 0.320	—	B	18	TH	NSC LM258X (T2)
<b>4.5 – 8.5 Vdc input</b>														
FA2469-AL	4.0	-48 V, 0.083 A	—	125	1 : 16	—	19	0.036	16.5	—	A	4	SM	STMicro STLC3075
<b>5 – 24 Vdc input</b>														
HA3994-AL		5 V, 3.6 A 15 V, 1.2 A -15 V, 1.2 A	—	100	1 : 0.5 1 : 1.5 1 : 1.5	—	7.5	0.018	0.020 0.031 0.031	—	C	16	SM	Linear LT3751 Capacitor Charger
<b>8.5 – 12 Vdc input</b>														
FA2470-AL	4.0	-48 V, 0.083 A	—	125	1 : 8	—	19	0.036	7.920	—	A	4	SM	STMicro STLC3075
<b>9 – 20 Vdc input</b>														
IFLY0012	4.1	24 V, 0.17 A 72 V, 0.17 A	—	600	1 : 3 1 : 9	—	6.0	0.021	0.690 2.070	—	C	10	SM	Intersil ISL6401
<b>10 – 14 Vdc input</b>														
GA3431-BL	5.0	3.3 V, 1.5 A	3.3 V, 20 mA	250	1 : 0.14	1 : 0.14	25	0.090	0.005	0.070	D	7	SM	Linear LT3573
GA3430-BL	5.0	5.0 V, 1.0 A	5.0 V, 20 mA	250	1 : 0.20	1 : 0.20	25	0.090	0.015	0.095	D	7	SM	Linear LT3573
<b>18 – 36 Vdc input</b>														
Q4437-BL	9.0	5.0 V, 1.8 A 12 V, 0.25 A -12 V, 0.25 A	—	100	1 : 0.5 1 : 1.167 1 : 1.167	—	55	0.110	0.035 0.300 0.320	—	C	15	SM	NSC LM258X (T5)
Q4338-BL	9.0	5.0 V, 1.8 A 12 V, 0.25 A -12 V, 0.25 A	—	100	1 : 0.5 1 : 1.167 1 : 1.167	—	66	0.090	0.039 0.580 0.600	—	C	18	TH	NSC LM258X (T5)
Q4438-BL	7.6	12 V, 0.63 A -12 V, 0.63 A	—	100	1 : 1.2 1 : 1.2	—	65	0.065	0.150 0.150	—	B	15	SM	NSC LM258X (T6)
Q4339-BL	7.6	12 V, 0.63 A -12 V, 0.63 A	—	100	1 : 1.2 1 : 1.2	—	66	0.090	0.200 0.240	—	B	18	TH	NSC LM258X (T6)
Q4344-BL	9.0	12 V, 0.75 A -12 V, 0.75 A 5.0 V, 3 A	—	100	1 : 0.35 1 : 0.8 1 : 0.8	—	85	0.145	0.200 0.200 0.030	—	C	22	TH	NSC LM258X (T4)
Q4343-BL	16.8	12 V, 1.4 A -12 V, 1.4 A	—	100	1 : 0.8 1 : 0.8	—	85	0.150	0.011 0.011	—	B	22	TH	NSC LM258X (T3)
<b>20 – 28 Vdc input</b>														
GA3429-BL	5.0	3.3 V, 1.5 A	3.3 V, 20 mA	250	1 : 0.25	1 : 0.25	24	0.095	0.0075	0.123	D	7	SM	Linear LT3573
<b>22 – 26 Vdc input</b>														
GA3136-BL	50	53 V, 0.17 A	—	150	1 : 1.4	1 : 0.33	35	0.029	0.074	0.208	D	16	SM	TI UCC2809
<b>ac line input (85 – 130 Vac)</b>														
A9619-CL	7.0	12 V, 0.58 A	—	100	1 : 0.1	1 : 0.14	3200	1.74	0.040	0.278	D	22	TH	ON Semi NCP101X
<b>ac line input (195 – 265 Vac)</b>														
B0570-BL	15	12 V, 1.25 A	—	100	1 : 0.06	1 : 0.08	3400	2.57	0.038	0.285	D	22	TH	ON Semi NCP101X
<b>Universal ac line input (85 – 265 Vac)</b>														
Y8844-AL	3.5	6.5 V, 0.54 A	—	100	1 : 0.08	—	2900	4.25	0.070	—	A	12	TH	ON Semi NCP1201
HA4018-AL	4.3	15 V, 0.05 A 5 V, 0.35 A -15 V, 1.125 A	12 V, 20 mA	50	1 : 0.12 1 : 0.067 1 : 0.189	1 : 0.156	2200	1.55	0.061 0.305 0.450	0.350	K	20	TH	TI UCC28600
HA3950-AL	5.0	15 V, 0.33 A	—	100	1 : 0.16	1 : 0.11	2.3	0.86	0.109	0.080	D	19	TH	TI UCC2813D-4
DA2077-AL	10	5.0 V, 2 A	12.5 V, 10 mA	65	1 : 0.06	1 : 0.15	3400	2.53	0.042	0.574	D	22	TH	ON Semi NCP1027
Y8848-AL	10	12 V, .83 A	—	100	1 : 0.10	—	1800	1.77	0.038	—	A	22	TH	ON Semi NCP1202
GA3172-AL	14	20 V / 0.7 A	12 V, 20 mA	250	1 : 0.214	1 : 0.131	500	0.675	0.245	0.325	D	17	TH	Microchip PIC16HV785
GA0007-AL	48	32 V, 1 A 16 V, 0.75 A	16 V, 20 mA	45	1 : 0.2 1 : 0.2	1 : 0.2	270	0.25	0.027 0.045	0.26	I	21	TH	ON Semi NCP1351
Z9007-BL	67	16 V, 4.2 A	—	100	1 : 0.16	—	700	0.261	0.065	—	A	24	TH	ON Semi NCP1200
Z9260-AL	67	16 V, 4.2 A	15 V, 1.2 A	100	1 : 0.16	1 : 0.15	700	0.261	0.065	0.450	D	24	TH	ON Semi NCP1200
GA3366-BL	90	19.5 V, 4.62 A	16 V, 20 mA	100	1 : 0.147	1 : 0.118	300	0.180	0.0053	0.073	D	26	TH	ON Semi NCP1606
FA2443-AL	120	19.4 V, 6.2 A	—	140	1 : 0.167	1 : 0.167	200	0.217	0.010	0.515	D	25	TH	TI UCC28600

# Coilcraft®

Specification subject to change without notice.  
Please check our website for latest information.

Document 651-3 Revised 02/01/10

1102 Silver Lake Road Cary, Illinois 60013 Phone 847/639-6400 Fax 847/639-1469  
E-mail info@coilcraft.com Web http://www.coilcraft.com



# Capacitor Charging Transformers

Part number	Peak input current (A)	Output voltage	Aux / bias output	Nominal freq. (kHz)	Turns ratio			L at 0 A (µH)	DCR (Ohms)			Schem	Body size	Mtg	Designed for
					pri : sec	pri : aux / bias	aux / bias		pri	sec	aux / bias				
CJ5143-AL	1.2	350	—	100	1 : 15	—	15	1.0	25	—	A	1	SM	ON NCP5080 Capacitor Charger	
HA4060-AL	2.0	500	—	100	1 : 3	—	300	0.422	1.58	—	A	16	SM	Linear LT3751 Capacitor Charger	
DA2032-AL	3.0	300	—	100	1 : 10	—	10	0.013	1.60	—	A	9	SM	Linear LT3750 Capacitor Charger	
DA2033-AL	5.0	300	—	100	1 : 10	—	10	0.015	1.10	—	A	11	SM	Linear LT3750 Capacitor Charger	
HA4061-AL	5.0	500	—	100	1 : 3	—	125	0.203	1.40	—	A	23	TH	Linear LT3751 Capacitor Charger	
DA2034-AL	10	300	—	100	1 : 10	—	10	0.018	1.75	—	A	14	SM	Linear LT3750 Capacitor Charger	
GA3459-BL	20	500	—	50	1 : 10	—	5.0	0.0077	0.515	—	A	16	SM	Linear LT3751 Capacitor Charger	
GA3460-BL	50	500	—	50	1 : 10	—	2.5	0.0056	0.400	—	A	16	SM	Linear LT3751 Capacitor Charger	

## Schematics

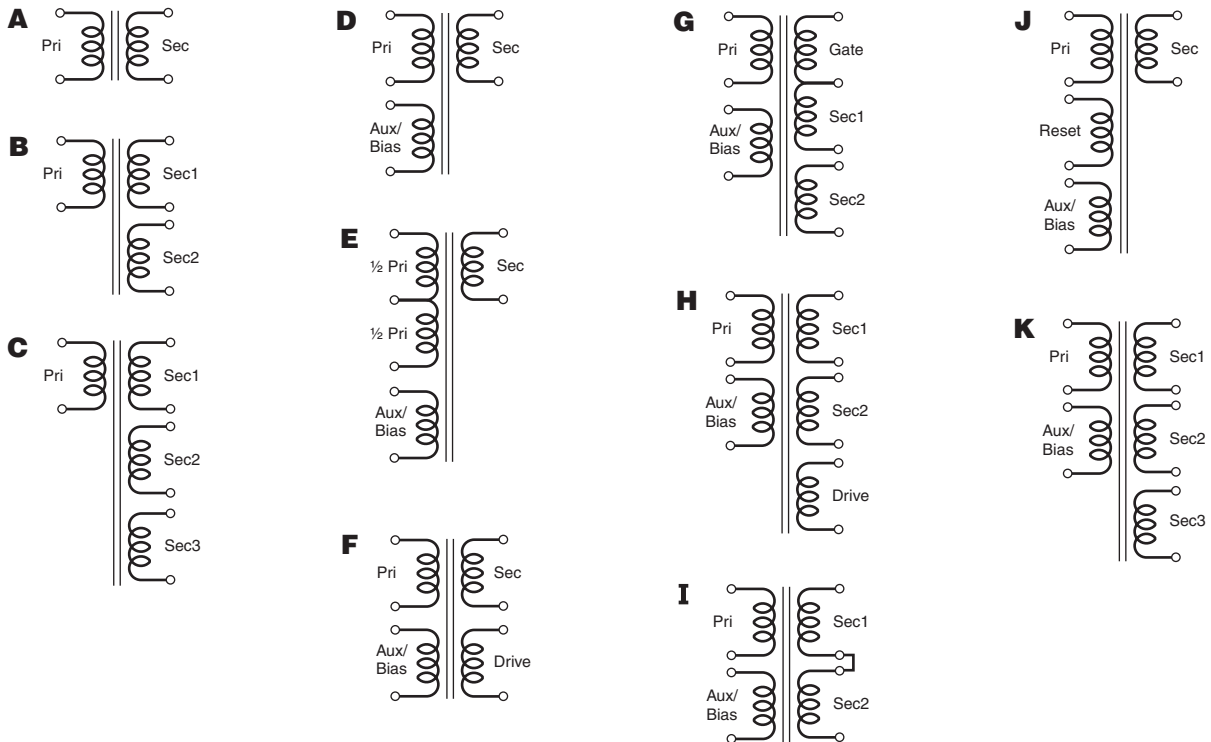

Specification subject to change without notice.  
Please check our website for latest information.

Document 651-4 Revised 02/01/10

1102 Silver Lake Road Cary, Illinois 60013 Phone 847/639-6400 Fax 847/639-1469  
E-mail [info@coilcraft.com](mailto:info@coilcraft.com) Web <http://www.coilcraft.com>



# Flyback Transformers

## Dimensions

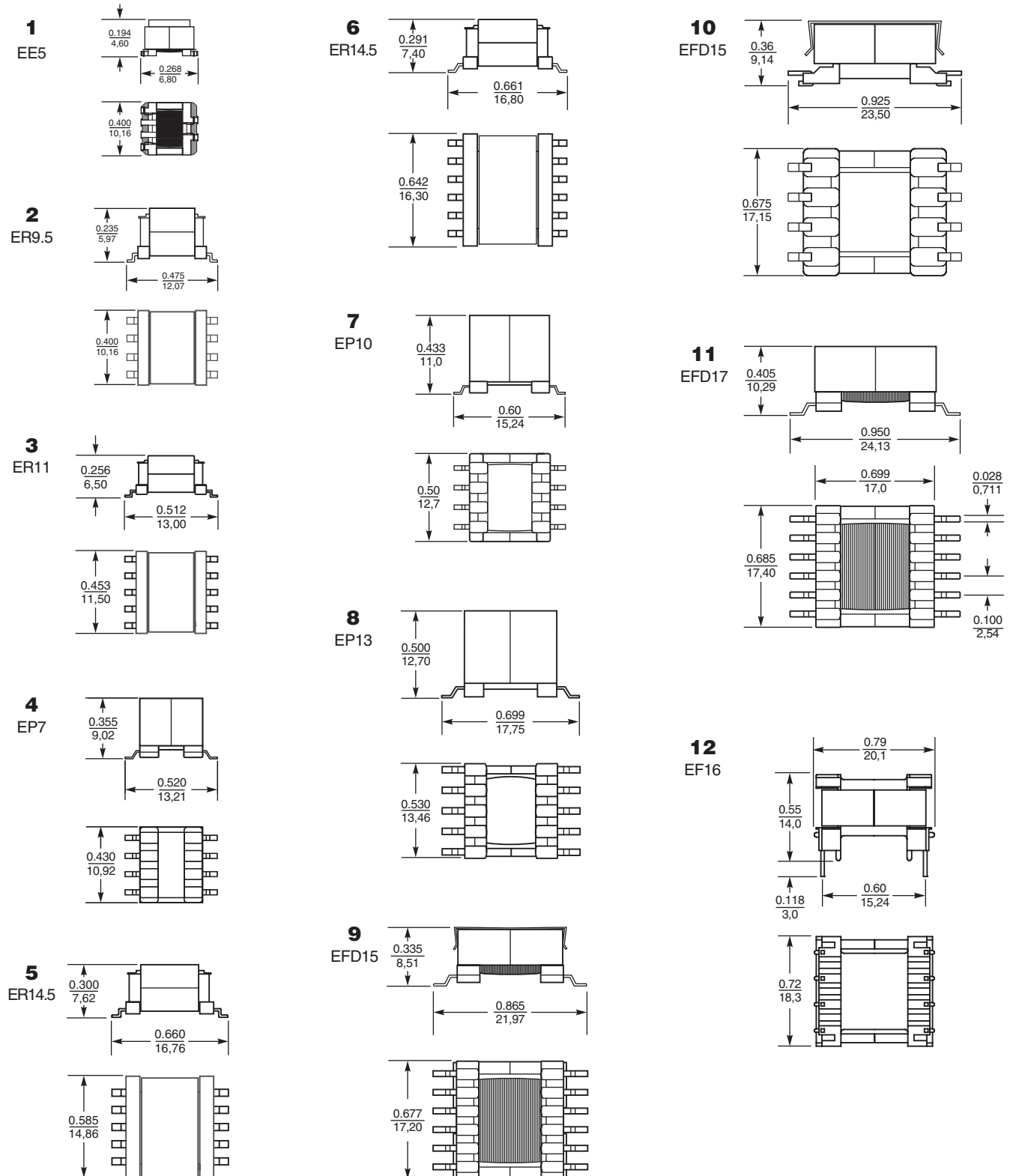

Specification subject to change without notice.  
 Please check our website for latest information.

Document 651-5 Revised 02/01/10

1102 Silver Lake Road Cary, Illinois 60013 Phone 847/639-6400 Fax 847/639-1469  
 E-mail [info@coilcraft.com](mailto:info@coilcraft.com) Web <http://www.coilcraft.com>



# Flyback Transformers

## Dimensions

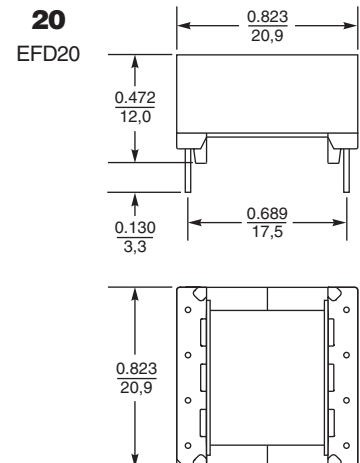
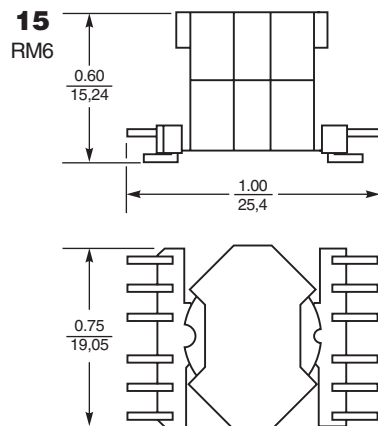
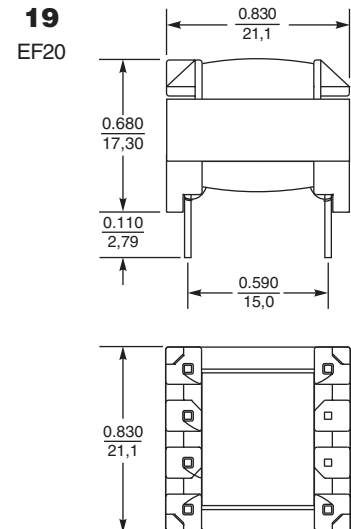
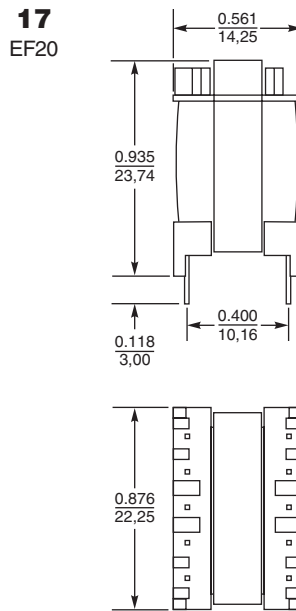
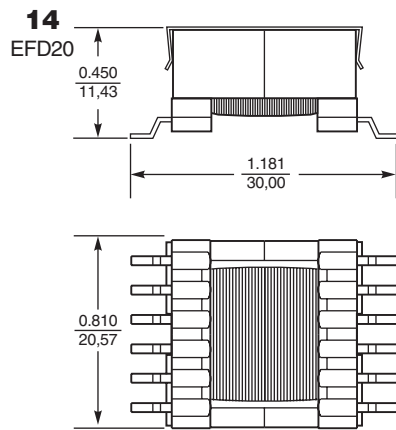
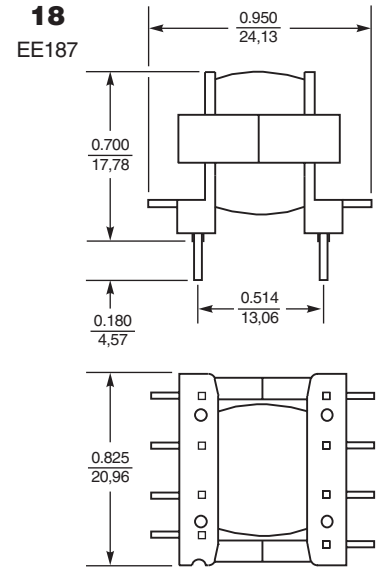
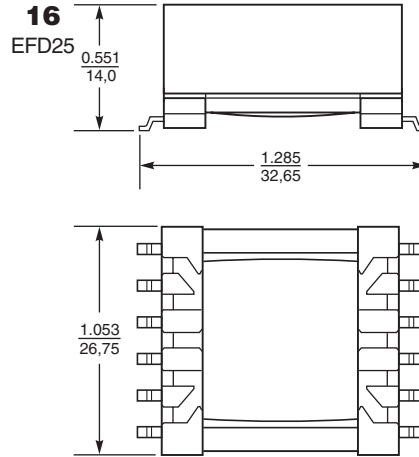
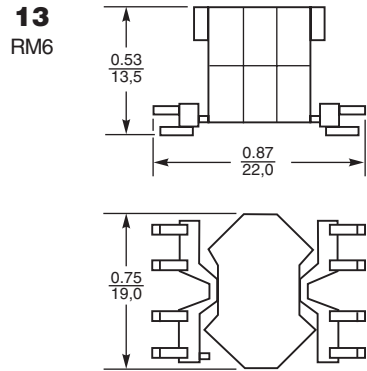

**Coilcraft**<sup>®</sup>

Specification subject to change without notice.  
Please check our website for latest information.

Document 651-6 Revised 02/01/10

1102 Silver Lake Road Cary, Illinois 60013 Phone 847/639-6400 Fax 847/639-1469

E-mail [info@coilcraft.com](mailto:info@coilcraft.com) Web <http://www.coilcraft.com>



# Flyback Transformers

## Dimensions

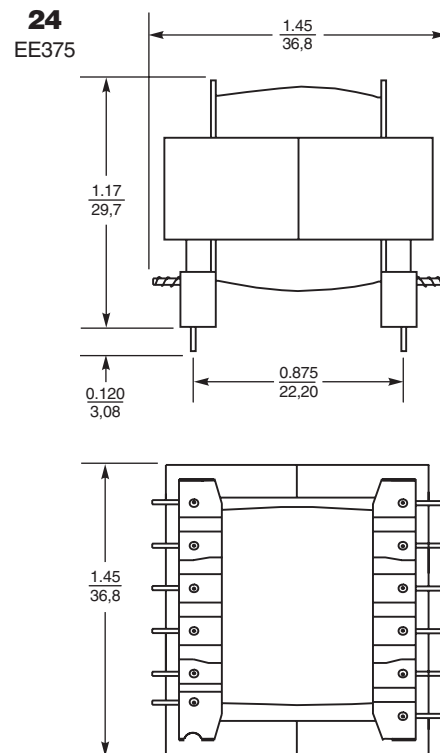
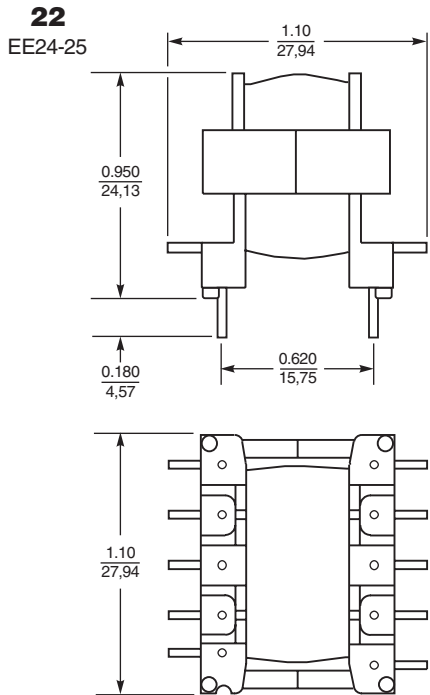
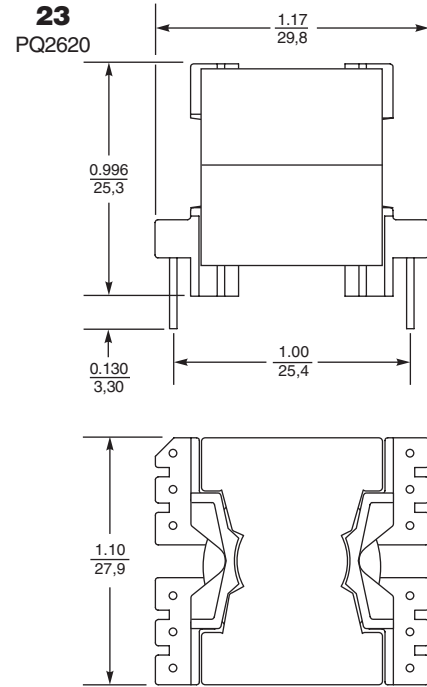
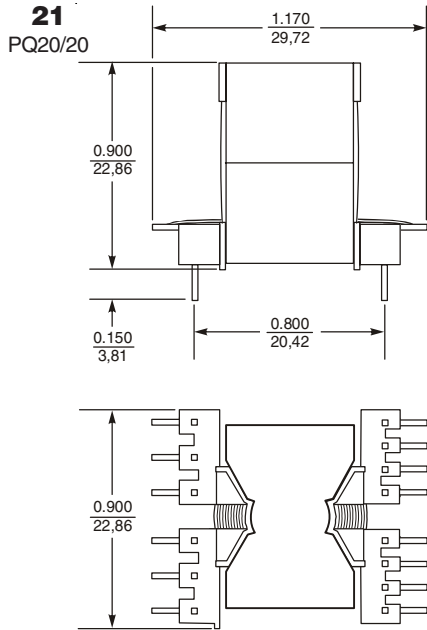

Specification subject to change without notice.  
Please check our website for latest information.

Document 651-7 Revised 02/01/10

1102 Silver Lake Road Cary, Illinois 60013 Phone 847/639-6400 Fax 847/639-1469  
E-mail [info@coilcraft.com](mailto:info@coilcraft.com) Web <http://www.coilcraft.com>



# Flyback Transformers

## Dimensions

**25**  
EE21

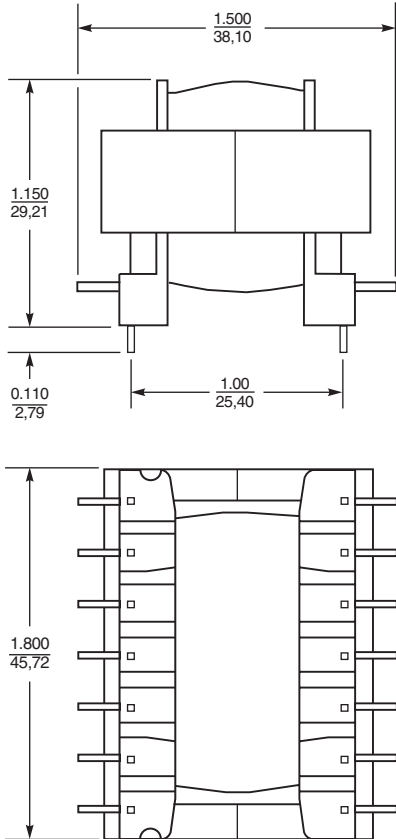

**26**  
EER35L

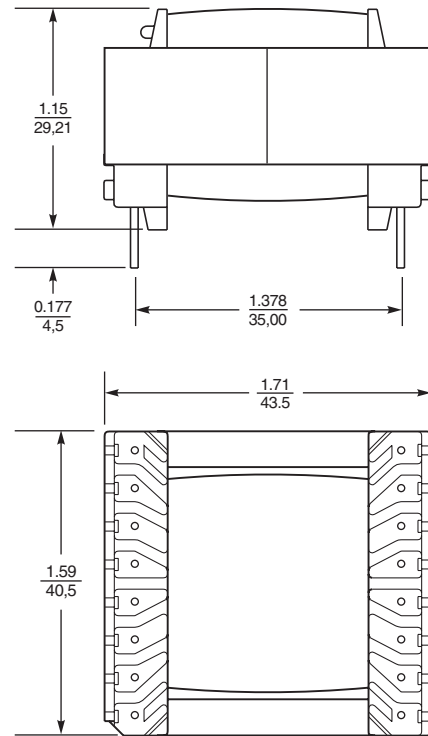

**Coilcraft**<sup>®</sup>

Specification subject to change without notice.  
Please check our website for latest information.

Document 651-8 Revised 02/01/10

1102 Silver Lake Road Cary, Illinois 60013 Phone 847/639-6400 Fax 847/639-1469

E-mail [info@coilcraft.com](mailto:info@coilcraft.com) Web <http://www.coilcraft.com>