

Features

- Built-in diagnostic function to detect short and open circuiting of loads and output status signals
- DMOS 2ch output
- Allows ON/OFF using C-MOS logic level
- Built-in overcurrent and thermal protection circuits

Absolute Maximum Ratings

(Ta=25°C)

Parameter	Symbol	Ratings	Unit	Conditions
Power supply voltage	V _B	35	V	
Input terminal voltage	V _{IN}	-0.3 to 7	V	
Input terminal current	I _{IN}	5	mA	
DG terminal voltage	V _{DG}	-0.3 to 7	V	
DG terminal current	I _{DG}	5	mA	
Drain to source voltage	V _{DS}	V _B -45	V	
Output current	I _O	1.8	A	
Power dissipation	P _D	2	W	Ta=25°C
Source to drain Di forward current	I _F	0.8	A	
Channel temperature	T _{ch}	150	°C	
Operating temperature	T _{OP}	-40 to +105	°C	
Storage temperature	T _{stg}	-40 to +150	°C	

Electrical Characteristics

(V_B=14V, Ta=25°C unless otherwise specified)

Parameter	Symbol	Ratings			Unit	Conditions	
		min	typ	max			
Operating power supply voltage	V _{B(OPP)}	5.5		35	V		
Quiescent circuit current	I _q			1	mA	V _{IN} =0V, V _{OUT} =0V	
Output ON resistance	R _{DS(ON)}			200	mΩ	I _O =1A	
				300	mΩ	I _O =1A, Ta=80°C	
Output leak current	I _{O, leak}		50	100	μA	V _{OUT} =0V	
Input threshold voltage	Output ON	V _{IHth}	1.4	2.0	3.0	V	Ta=-40 to +105°C
	Output OFF	V _{ILth}	1.0	1.8		V	Ta=-40 to +105°C
Input current	Output ON	I _{IH}		70	200	μA	V _{IN} =5V
	Output OFF	I _{IL}			12	μA	V _{IN} =0V
Overcurrent protection starting current	I _S	1.9		3	A	V _{OUT} =V _O -1.5V	
Internal current limit	I _{LIM}			5	A	V _{OUT} =0V	
Thermal shutdown operating temperature	T _{TSD}	155	165		°C		
Load open detection threshold voltage	V _{open}	1.5	3	4.5	V		
Output transfer time	*1	T _{ON}	70	140		μs	R _L =14Ω, V _O =-5V
		T _{OFF}	35	90		μs	R _L =14Ω, V _O ≠10%
DG leak current	I _{DG}			20	μA	V _{DG} =5.5V	
Low level DG output voltage	*1	V _{DGL}	0.15	0.5		V	I _{DG} =1.6mA
		T _{PLH}	70	140		μs	
DG output transfer time	*1	T _{PHL}	45	120		μs	

Note: *1. Transient time is showed Wave Form below.

Recommended Operating Conditions (for one channel)

Parameter	Ratings		Unit
	min	max	
Power supply voltage	5.5	16	V
V _{IH}	4	5.5	V
V _{IL}	-0.3	0.9	V
I _O		1	A
R _{IN}	10	20	kΩ
R _{DG}	10	20	kΩ

Wave Form

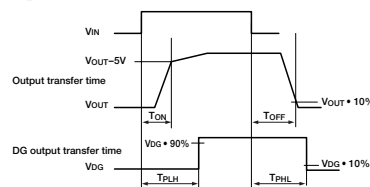

External Dimensions (unit: mm)

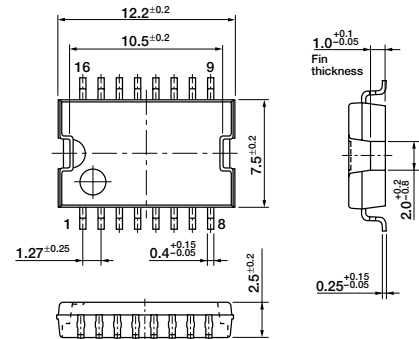

Block Diagram (for one channel)

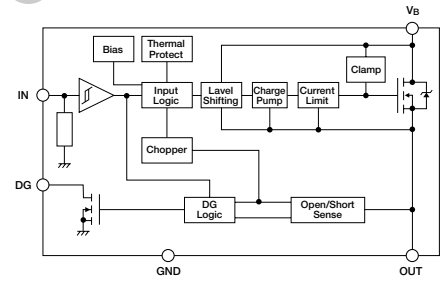

Standard Connection Diagram

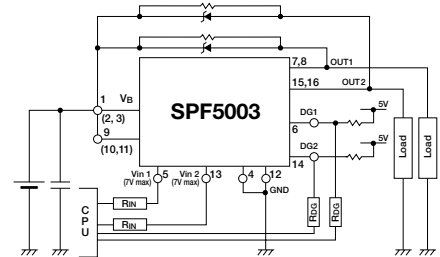

* R_{IN} and R_{DG} are needed to protect CPU and SPF5003 in case of reverse connection of V_B terminal.
* Make V_B of 1Pin and 9Pin short from the fin to be plated by solder.

Timing Chart

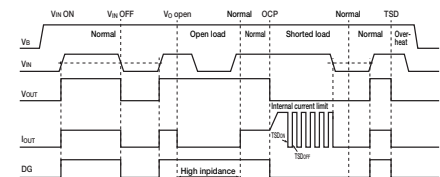

Mode	V _{IN}	DG	V _O
Normal	H	H	H
	L	L	L
Open load	H	H	H
	L	H	H
Shorted load	H	L	L (Limiting)
	L	L	L
Overheat	H	L	L
	L	L	L