

Features

- Designed to Store Configurator Programs for Field Programmable System Level Integrated Circuits (FPSLICs)
- In-System Programmable (ISP) via 2-wire Bus
- Spare Memory Available for System Parameters Storage
- Low-power CMOS EEPROM Process
- Available in 6 mm x 6 mm x 1 mm 8-lead LAP Package (Pin Compatible Across Product Family)
- Emulation of Atmel's AT24CXXX Serial EEPROMs
- Available in 3.3V \pm 10% LV
- Low-power Standby Mode
- High-reliability
 - Endurance: 100,000 Write Cycles
 - Data Retention: 90 Years for Industrial Parts (at 85°C) and 190 Years for Commercial Parts (at 70°C)

Description

The FPSLIC Support Devices provide an easy-to-use, cost-effective configuration memory for programming Field Programmable System Level Integrated Circuits by using a simple serial-access procedure to configure one or more FPSLIC devices. See Table 1 for a list of supported FPSLIC devices.

The FPSLIC Support Device can be programmed with industry-standard programmers, Atmel's ATDH2200E Programming Kit or Atmel's ATDH2225 ISP Cable.

Table 1. ATFS FPSLIC Support Devices

FPSLIC Device	FPSLIC Support Device	Configuration Data	Spare Memory
AT94K05	ATFS05	226520 Bits	35624 Bits
AT94K10	ATFS10	430488 Bits	93800 Bits
AT94K40	ATFS40	815382 Bits	233194 Bits

Pin Configurations

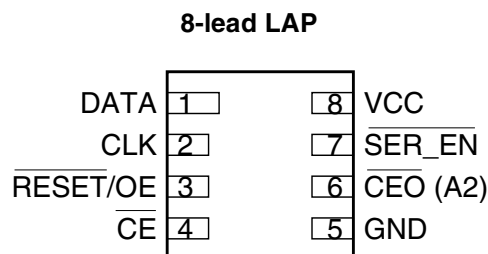

Support Device

ATFS05

ATFS10

ATFS40

Advance Information

Rev. 3017C-FPSLI-07/02



Block Diagram

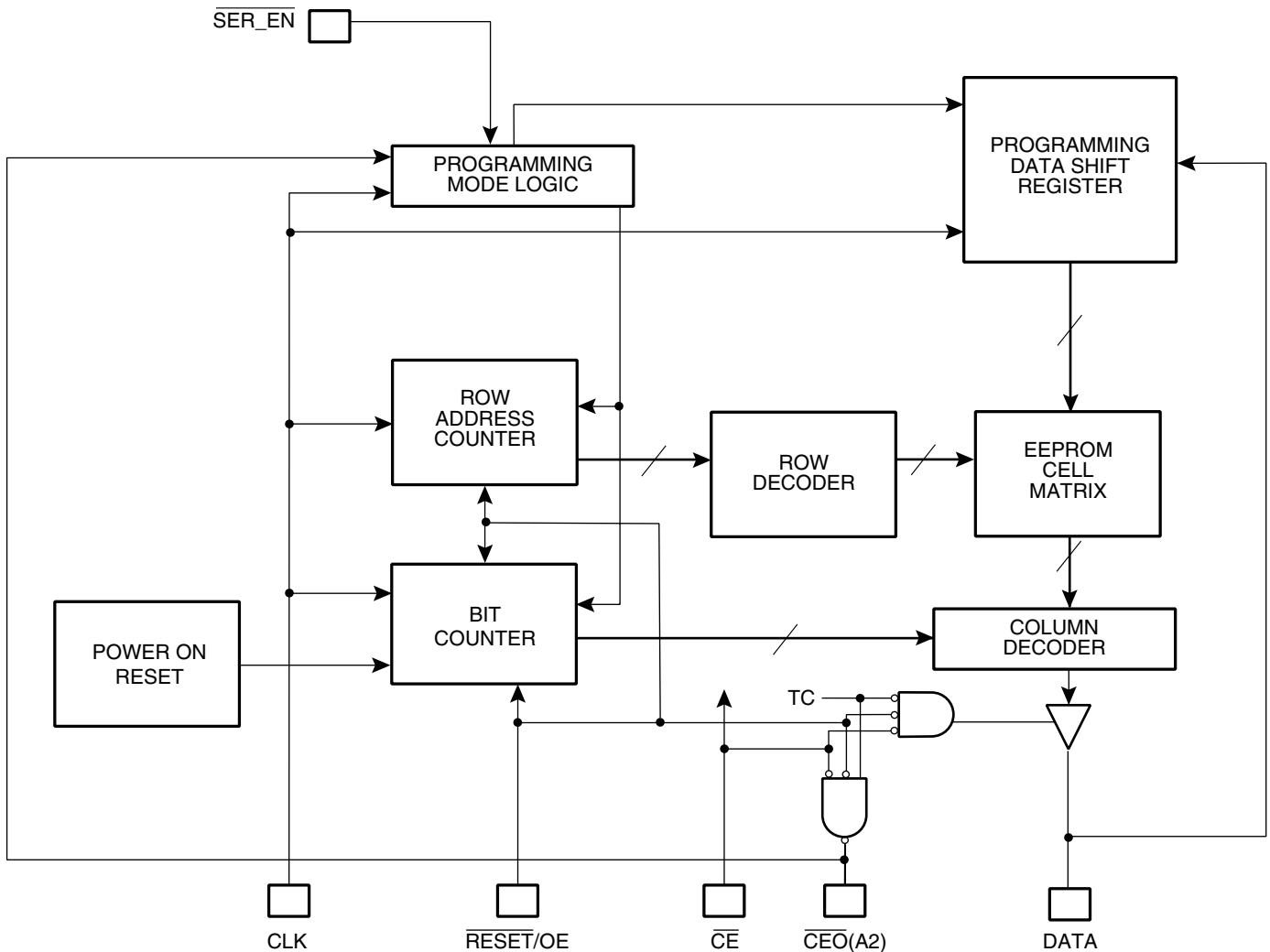

Device Description

The control signals for the FPSLIC Support Device (\overline{CE} , $\overline{RESET/OE}$ and CCLK) interface directly with the FPSLIC control signals. All FPSLIC devices can control the entire configuration process and retrieve data from the FPSLIC Support Device without requiring an external intelligent controller.

The $\overline{RESET/OE}$ and \overline{CE} pins control the tri-state buffer on the DATA output pin and enable the address counter. When $\overline{RESET/OE}$ is driven Low, the configuration EEPROM resets its address counter and tri-states its DATA pin. The \overline{CE} pin also controls the output of the FPSLIC Support Device. If \overline{CE} is held High after the $\overline{RESET/OE}$ reset pulse, the counter is disabled and the DATA output pin is tri-stated. When OE is subsequently driven High, the counter and the DATA output pin are enabled. When $\overline{RESET/OE}$ is driven Low again, the address counter is reset and the DATA output pin is tri-stated, regardless of the state of \overline{CE} .

When the FPSLIC Support Device has driven out all of its data and \overline{CEO} is driven Low, the device tri-states the DATA pin to avoid contention with other FPSLIC Support Devices. Upon power-up, the address counter is automatically reset.

Pin Description

8 LAP Pin	Name	I/O	Description
1	DATA	I/O	Tri-state DATA output for configuration. Open-collector bi-directional pin for programming.
2	CLK	I	Clock input. Used to increment the internal address and bit counter for reading and programming.
3	$\overline{\text{RESET/OE}}$	I	Output Enable (active High) and RESET (active Low) when $\overline{\text{SER_EN}}$ is High. A Low level on $\overline{\text{RESET/OE}}$ resets both the address and bit counters. A High level (with $\overline{\text{CE}}$ Low) enables the data output driver.
4	$\overline{\text{CE}}$	I	Chip Enable input (active Low). A Low level (with OE High) allows DCLK to increment the address counter and enables the data output driver. A High level on $\overline{\text{CE}}$ disables both the address and bit counters and forces the device into a low-power standby mode. Note that this pin will <i>not</i> enable/disable the device in the 2-wire Serial Programming mode ($\overline{\text{SER_EN}}$ Low).
5	GND		Ground pin. A 0.2 μF decoupling capacitor between V_{CC} and GND is recommended.
6	A2	I	Device selection input, A2. This is used to enable (or select) the device during programming (i.e., when $\overline{\text{SER_EN}}$ is Low). A2 has an internal pull-down resistor.
7	$\overline{\text{SER_EN}}$	I	Serial enable must be held High during FPSLIC loading operations. Bringing $\overline{\text{SER_EN}}$ Low enables the 2-wire Serial Programming Mode. For non-ISP applications, $\overline{\text{SER_EN}}$ should be tied to V_{CC} .
8	V_{CC}		+3.3V power supply pin

FPSLIC Master Serial Mode Summary

The I/O and logic functions of the FPSLIC devices are established by a configuration program. The program is loaded either automatically upon power-up, or on command, depending on the state of the mode pins. In Master Mode, the FPSLIC automatically loads the configuration program from an external memory. The FPSLIC Support Device has been designed for compatibility with the Master Mode.

Control of Configuration

Most connections between the FPSLIC device and the FPSLIC Support Device are simple and self-explanatory:

- The DATA output of the FPSLIC Support Device drives DIN of the FPSLIC devices.
- The master FPSLIC CCLK output drives the CLK input of the FPSLIC Support Device.
- $\overline{\text{SER_EN}}$ must be connected to V_{CC} (except during ISP).

Programming Mode

The programming mode is entered by bringing $\overline{\text{SER_EN}}$ Low. In this mode the chip can be programmed by the 2-wire serial bus. The programming is done at V_{CC} supply only. Programming super voltages are generated inside the chip.

Standby Mode

The FPSLIC Support Device enters a low-power standby mode whenever $\overline{\text{CE}}$ is asserted High. In this mode, the ATFS05 consumes less than 50 μA of current at 3.3V. The output remains in a high-impedance state regardless of the state of the $\overline{\text{OE}}$ input.

Example Circuits

Figure 1. FPSLIC Support Device for Programming FPSLIC Devices

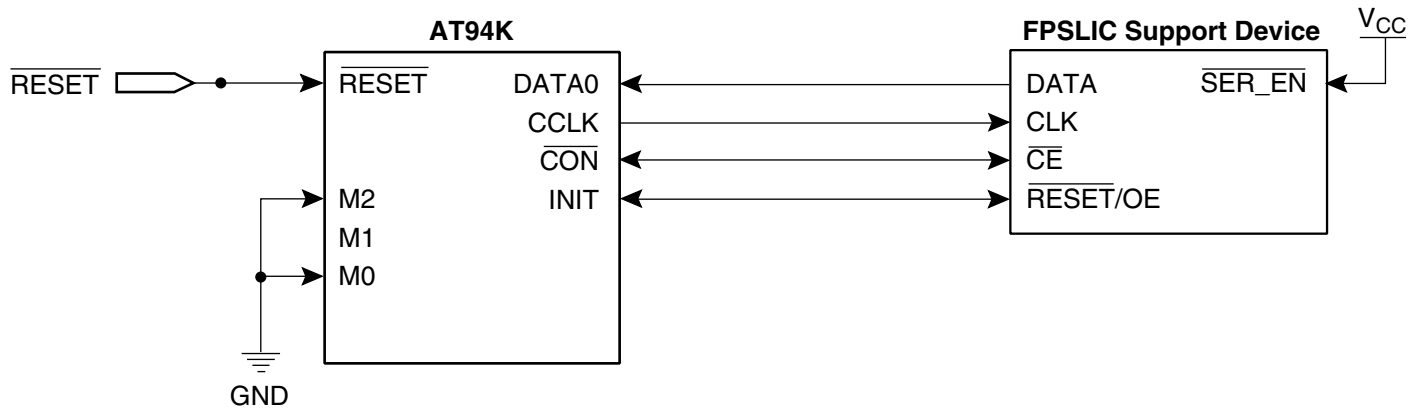

The FPSLIC's bi-directional $\overline{\text{CON}}$ pin drives the $\overline{\text{CE}}$ input of the FPSLIC Support Device, while the $\overline{\text{RESET/OE}}$ input is driven by the FPSLIC's bi-directional $\overline{\text{INIT}}$ pin. This connection works under all normal circumstances, even when the user aborts the configuration before $\overline{\text{CON}}$ has gone High. A Low level on the $\overline{\text{RESET/OE}}$ input, during FPSLIC reset, clears the FPSLIC Support Device's internal address pointer so that the reconfiguration starts at the beginning.

The spare memory can be accessed by in-system programming the ATFS through a two-wire serial interface built in the FPSLIC device. For more information, refer to the "C Code for Interfacing the FPSLIC AVR Core to AT17 Series Configuration Memories" application note, available on the Atmel web site (www.atmel.com).

Figure 2. In-System Programming of FPSLIC Support Devices

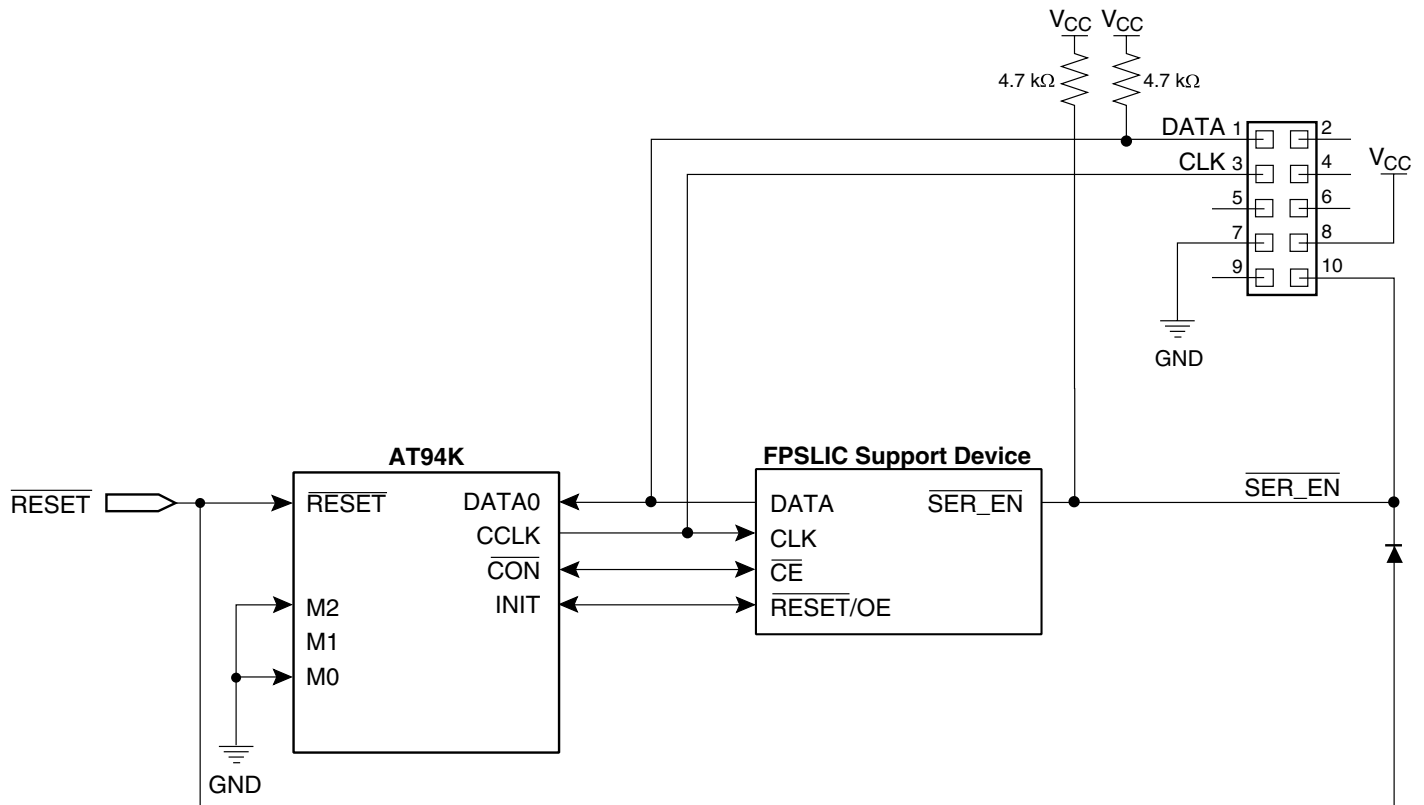

Absolute Maximum Ratings*

Operating Temperature	-55°C to +125°C
Storage Temperature	-65°C to +150°C
Voltage on Any Pin with Respect to Ground	-0.1V to $V_{CC} + 0.5V$
Supply Voltage (V_{CC})	-0.5V to +7.0V
Maximum Soldering Temp. (10 sec. @ 1/16 in.).....	260°C
ESD ($R_{ZAP} = 1.5K, C_{ZAP} = 100 \text{ pF}$).....	2000V

*NOTICE: Stresses beyond those listed under Absolute Maximum Ratings may cause permanent damage to the device. This is a stress rating only and functional operation of the device at these or any other conditions beyond those listed under operating conditions is not implied. Exposure to Absolute Maximum Rating conditions for extended periods of time may affect device reliability.

Operating Conditions

Symbol	Description		ATFS05/10/40		Units
			Min	Max	
V_{CC}	Commercial	Supply voltage relative to GND -0°C to +70°C	3.0	3.6	V
	Industrial	Supply voltage relative to GND -40°C to +85°C	3.0	3.6	V

DC Characteristics – ATFS05

$V_{CC} = 3.3V \pm 10\%$

Symbol	Description	Min	Max	Units
V_{IH}	High-level Input Voltage	2.0	V_{CC}	V
V_{IL}	Low-level Input Voltage	0	0.8	V
V_{OH}	High-level Output Voltage ($I_{OH} = -2.5$ mA)	2.4	0.4	V
V_{OL}	Low-level Output Voltage ($I_{OL} = +3$ mA)			
V_{OH}	High-level Output Voltage ($I_{OH} = -2$ mA)	2.4	0.4	V
V_{OL}	Low-level Output Voltage ($I_{OL} = +3$ mA)			
I_{CCA}	Supply Current, Active Mode		5	mA
I_L	Input or Output Leakage Current ($V_{IN} = V_{CC}$ or GND)	-10	10	μ A
I_{CCS}	Supply Current, Standby Mode	Commercial	50	μ A
		Industrial	100	μ A

DC Characteristics – ATFS10/40

$V_{CC} = 3.3V \pm 10\%$

Symbol	Description	Min	Max	Units
V_{IH}	High-level Input Voltage	2.0	V_{CC}	V
V_{IL}	Low-level Input Voltage	0.0	0.8	V
V_{OH}	High-level Output Voltage ($I_{OH} = -2.5$ mA)	2.4	0.4	V
V_{OL}	Low-level Output Voltage ($I_{OL} = +3$ mA)			
V_{OH}	High-level Output Voltage ($I_{OH} = -2$ mA)	2.4	0.4	V
V_{OL}	Low-level Output Voltage ($I_{OL} = +3$ mA)			
I_{CCA}	Supply Current, Active Mode		5	mA
I_L	Input or Output Leakage Current ($V_{IN} = V_{CC}$ or GND)	-10	10	μ A
I_{CCS}	Supply Current, Standby Mode	Commercial	100	μ A
		Industrial	100	μ A

AC Characteristics

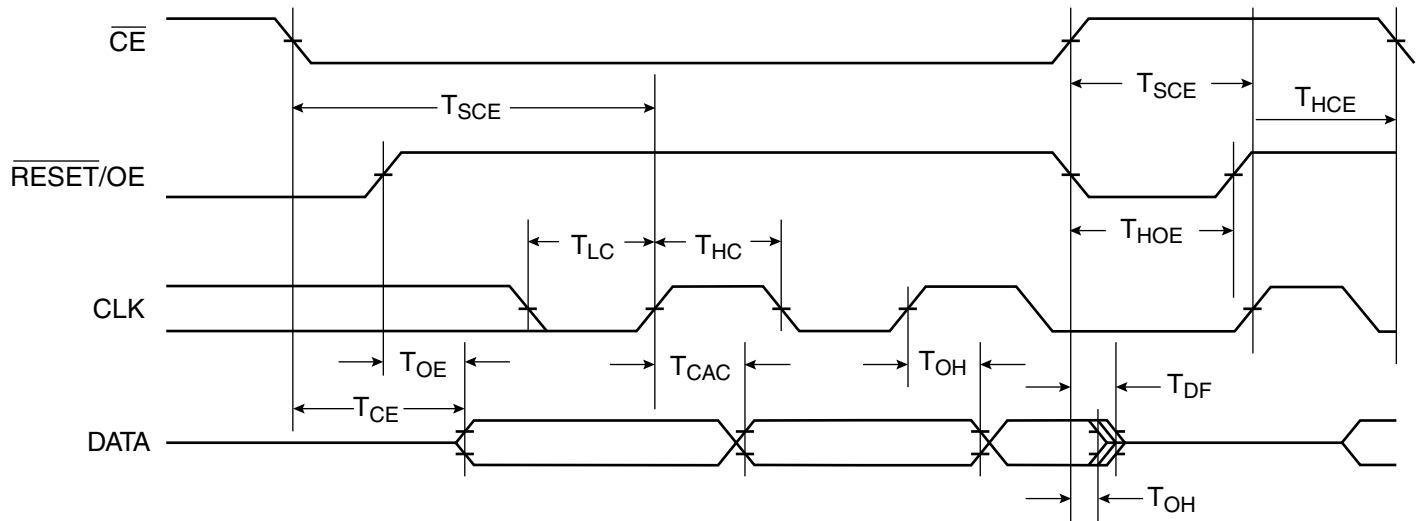

AC Characteristics When Cascading

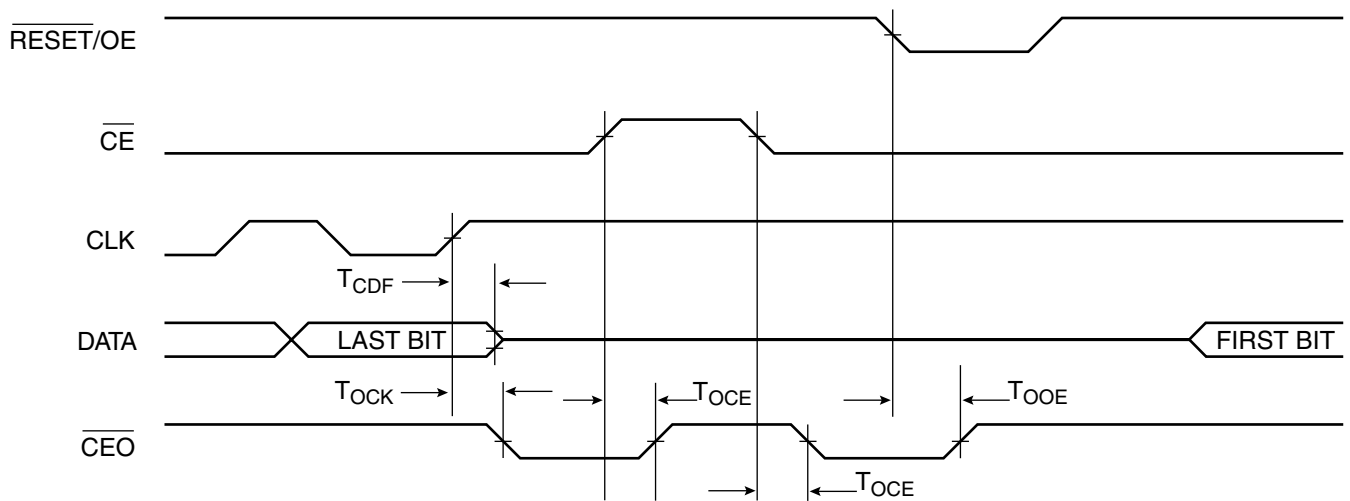

AC Characteristics for ATFS05

$V_{CC} = 3.3V \pm 10\%$

Symbol	Description	Commercial		Industrial		Units
		Min	Max	Min	Max	
$T_{OE}^{(1)}$	\overline{OE} to Data Delay		50		55	ns
$T_{CE}^{(1)}$	\overline{CE} to Data Delay		60		60	ns
$T_{CAC}^{(1)}$	CLK to Data Delay		75		80	ns
T_{OH}	Data Hold from \overline{CE} , \overline{OE} , or CLK	0		0		ns
$T_{DF}^{(2)}$	\overline{CE} or \overline{OE} to Data Float Delay		55		55	ns
T_{LC}	CLK Low Time	25		25		ns
T_{HC}	CLK High Time	25		25		ns
T_{SCE}	\overline{CE} Setup Time to CLK (to guarantee proper counting)	35		60		ns
T_{HCE}	\overline{CE} Hold Time from CLK (to guarantee proper counting)	0		0		ns
T_{HOE}	\overline{OE} High Time (guarantees counter is reset)	25		25		ns
F_{MAX}	Maximum Input Clock Frequency	10		10		MHz

- Notes: 1. AC test lead = 50 pF.
 2. Float delays are measured with 5 pF AC loads. Transition is measured ± 200 mV from steady-state active levels.

AC Characteristics for ATFS05 when Cascading

$V_{CC} = 3.3V \pm 10\%$

Symbol	Description	Commercial		Industrial		Units
		Min	Max	Min	Max	
$T_{CDF}^{(1)}$	CLK to Data Float Delay		60		60	ns
F_{MAX}	Maximum Input Clock Frequency	8		8		MHz

- Note: 1. Float delays are measured with 5 pF AC loads. Transition is measured ± 200 mV from steady state active levels.

AC Characteristics for ATFS10/40

$V_{CC} = 3.3V \pm 10\%$

Symbol	Description	Commercial		Industrial		Units
		Min	Max	Min	Max	
$T_{OE}^{(1)}$	\overline{OE} to Data Delay		50		55	ns
$T_{CE}^{(1)}$	\overline{CE} to Data Delay		55		60	ns
$T_{CAC}^{(1)}$	CLK to Data Delay		55		60	ns
T_{OH}	Data Hold From \overline{CE} , \overline{OE} , or CLK	0		0		ns
$T_{DF}^{(2)}$	\overline{CE} or \overline{OE} to Data Float Delay		50		50	ns
T_{LC}	CLK Low Time	25		25		ns
T_{HC}	CLK High Time	25		25		ns
T_{SCE}	\overline{CE} Setup Time to CLK (to guarantee proper counting)	30		35		ns
T_{HCE}	\overline{CE} Hold Time from CLK (to guarantee proper counting)	0		0		ns
T_{HOE}	\overline{OE} High Time (guarantees counter is reset)	25		25		ns
F_{MAX}	MAX Input Clock Frequency	15		10		MHz

Notes: 1. AC test load = 50 pF.
2. Float delays are measured with 5 pF AC loads. Transition is measured ± 200 mV from steady state active levels.

AC Characteristics for ATFS10/40 when Cascading

$V_{CC} = 3.3V \pm 10\%$

Symbol	Description	Commercial		Industrial		Units
		Min	Max	Min	Max	
$T_{CDF}^{(1)}$	CLK to Data Float Delay		50		50	ns
F_{MAX}	MAX Input Clock Frequency	12.5		10		MHz

Note: 1. Float delays are measured with 5 pF AC loads. Transition is measured ± 200 mV from steady state active levels.

Thermal Resistance Coefficients⁽¹⁾

Device	Package Type		θ_{JC} [°C/W]	θ_{JA} [°C/W]
				Airflow = 0 ft/min
ATFS05	Leadless Array Package (LAP)	8CN4	45	115.71
ATFS10/40	Leadless Array Package (LAP)	8CN4	45	135.71

Note: 1. For more information refer to the “Thermal Characteristics of Atmel’s Packages” application note, available on the Atmel web site.



Ordering Information

Ordering Code	Package	Operation Range
ATFS05-CC ATFS10-CC ATFS40-CC	8CN4 8CN4 8CN4	Commercial (0°C to 70°C)
ATFS05-CI ATFS10-CI ATFS40-CI	8CN4 8CN4 8CN4	Industrial (-40°C to 85°C)

Package Type	
8CN4	8-lead (6 x 6 x 1.04 mm Body), Lead Pitch 1.27 mm, Leadless Array Package (LAP)



Packaging Information

8CN4 – LAP

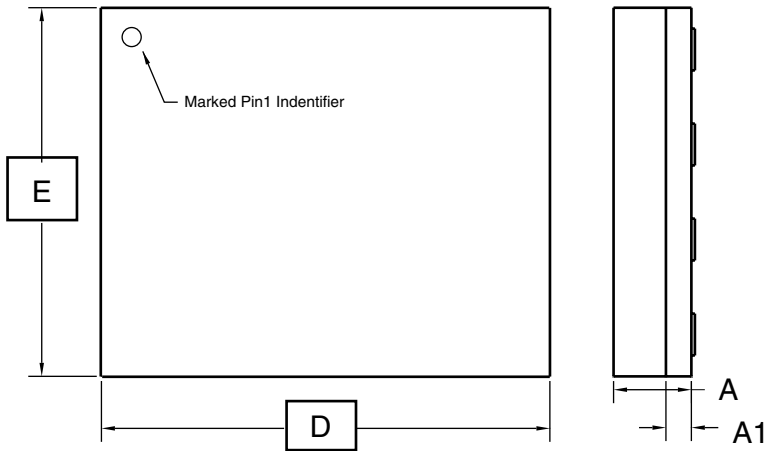

Top View

Side View

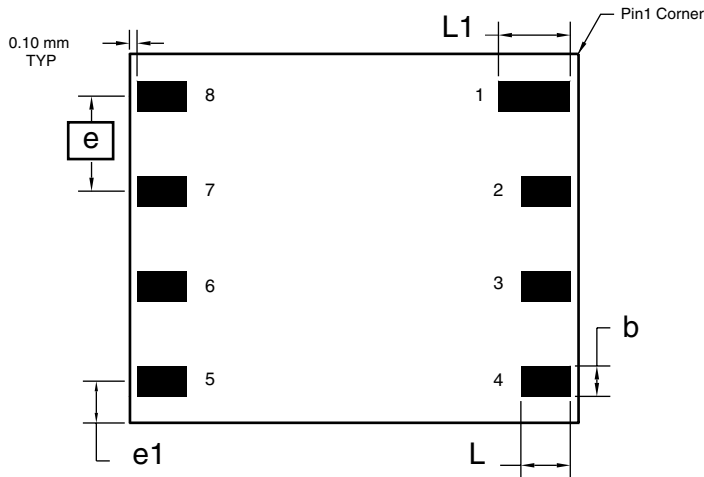

Bottom View

COMMON DIMENSIONS
(Unit of Measure = mm)

SYMBOL	MIN	NOM	MAX	NOTE
A	0.94	1.04	1.14	
A1	0.30	0.34	0.38	
b	0.45	0.50	0.55	1
D	5.89	5.99	6.09	
E	4.89	5.99	6.09	
e	1.27 BSC			
e1	1.10 REF			
L	0.95	1.00	1.05	1
L1	1.25	1.30	1.35	1

Note: 1. Metal Pad Dimensions.

11/14/01

ATMEL 2325 Orchard Parkway
San Jose, CA 95131

TITLE
8CN4, 8-lead (6 x 6 x 1.04 mm Body), Lead Pitch 1.27 mm,
Leadless Array Package (LAP)

DRAWING NO.
8CN4

REV.
A



Atmel Headquarters

Corporate Headquarters

2325 Orchard Parkway
San Jose, CA 95131
TEL 1(408) 441-0311
FAX 1(408) 487-2600

Europe

Atmel Sarl
Route des Arsenaux 41
Case Postale 80
CH-1705 Fribourg
Switzerland
TEL (41) 26-426-5555
FAX (41) 26-426-5500

Asia

Room 1219
Chinachem Golden Plaza
77 Mody Road Tsimshatsui
East Kowloon
Hong Kong
TEL (852) 2721-9778
FAX (852) 2722-1369

Japan

9F, Tonetsu Shinkawa Bldg.
1-24-8 Shinkawa
Chuo-ku, Tokyo 104-0033
Japan
TEL (81) 3-3523-3551
FAX (81) 3-3523-7581

Atmel Operations

Memory

2325 Orchard Parkway
San Jose, CA 95131
TEL 1(408) 441-0311
FAX 1(408) 436-4314

Microcontrollers

2325 Orchard Parkway
San Jose, CA 95131
TEL 1(408) 441-0311
FAX 1(408) 436-4314

La Chantrerie
BP 70602
44306 Nantes Cedex 3, France
TEL (33) 2-40-18-18-18
FAX (33) 2-40-18-19-60

ASIC/ASSP/Smart Cards

Zone Industrielle
13106 Rousset Cedex, France
TEL (33) 4-42-53-60-00
FAX (33) 4-42-53-60-01

1150 East Cheyenne Mtn. Blvd.
Colorado Springs, CO 80906
TEL 1(719) 576-3300
FAX 1(719) 540-1759

Scottish Enterprise Technology Park
Maxwell Building
East Kilbride G75 0QR, Scotland
TEL (44) 1355-803-000
FAX (44) 1355-242-743

RF/Automotive

Theresienstrasse 2
Postfach 3535
74025 Heilbronn, Germany
TEL (49) 71-31-67-0
FAX (49) 71-31-67-2340

1150 East Cheyenne Mtn. Blvd.
Colorado Springs, CO 80906
TEL 1(719) 576-3300
FAX 1(719) 540-1759

Biometrics/Imaging/Hi-Rel MPU/ High Speed Converters/RF Datacom

Avenue de Rochepleine
BP 123
38521 Saint-Egreve Cedex, France
TEL (33) 4-76-58-30-00
FAX (33) 4-76-58-34-80

Atmel Programmable SLI Hotline
(408) 436-4119

Atmel Programmable SLI e-mail
configurator@atmel.com

FAQ
Available on web site

e-mail
literature@atmel.com

Web Site
<http://www.atmel.com>

© Atmel Corporation 2002.

Atmel Corporation makes no warranty for the use of its products, other than those expressly contained in the Company's standard warranty which is detailed in Atmel's Terms and Conditions located on the Company's web site. The Company assumes no responsibility for any errors which may appear in this document, reserves the right to change devices or specifications detailed herein at any time without notice, and does not make any commitment to update the information contained herein. No licenses to patents or other intellectual property of Atmel are granted by the Company in connection with the sale of Atmel products, expressly or by implication. Atmel's products are not authorized for use as critical components in life support devices or systems.

Atmel® is the registered trademark of Atmel.

FLEX™ is the trademark of Altera Corporation; ORCA™ is the trademark of Lucent Technologies, Inc.; SPARTAN™ and Virtex™ are the trademarks of Xilinx, Inc.; APEX™ is the trademark of MIPS Technologies; Other terms and product names may be the trademarks of others.



Printed on recycled paper.

3017C-FPSLI-07/02

xM