

BF1205C

Dual N-channel dual gate MOS-FET

Rev. 02 — 15 August 2006

Product data sheet

1. Product profile

1.1 General description

The BF1205C is a combination of two dual gate MOS-FET amplifiers with shared source and gate 2 leads and an integrated switch. The integrated switch is operated by the gate 1 bias of amplifier b.

The source and substrate are interconnected. Internal bias circuits enable DC stabilization and a very good cross-modulation performance during AGC. Integrated diodes between the gates and source protect against excessive input voltage surges. The transistor has a SOT363 micro-miniature plastic package.

CAUTION



This device is sensitive to ElectroStatic Discharge (ESD). Therefore care should be taken during transport and handling.

1.2 Features

- Two low noise gain controlled amplifiers in a single package; one with a fully integrated bias and one with a partly integrated bias
- Internal switch to save external components
- Superior cross-modulation performance during AGC
- High forward transfer admittance
- High forward transfer admittance to input capacitance ratio.

1.3 Applications

- Gain controlled low noise amplifiers for VHF and UHF applications with 5 V supply voltage
 - ◆ digital and analog television tuners
 - ◆ professional communication equipment.

PHILIPS

1.4 Quick reference data

Table 1. Quick reference data
Per MOS-FET unless otherwise specified.

Symbol	Parameter	Conditions	Min	Typ	Max	Unit
V_{DS}	drain-source voltage		-	-	6	V
I_D	drain current (DC)		-	-	30	mA
P_{tot}	total power dissipation	$T_{sp} \leq 107\text{ }^\circ\text{C}$	[1]	-	180	mW
$ y_{fs} $	forward transfer admittance	$f = 1\text{ MHz}$				
		amplifier a; $I_D = 19\text{ mA}$	26	31	41	mS
		amplifier b; $I_D = 13\text{ mA}$	28	33	43	mS
C_{ig1-ss}	input capacitance at gate 1	$f = 1\text{ MHz}$				
		amplifier a	-	2.2	2.7	pF
		amplifier b	-	2.0	2.5	pF
C_{rss}	reverse transfer capacitance	$f = 1\text{ MHz}$	-	20	-	fF
NF	noise figure	amplifier a; $f = 400\text{ MHz}$	-	1.3	1.9	dB
		amplifier b; $f = 800\text{ MHz}$	-	1.4	2.1	dB
X_{mod}	cross-modulation	input level for $k = 1\%$ at 40 dB AGC				
		amplifier a	100	105	-	dB μ V
		amplifier b	100	103	-	dB μ V
T_j	junction temperature		-	-	150	$^\circ\text{C}$

[1] T_{sp} is the temperature at the soldering point of the source lead.

2. Pinning information

Table 2. Discrete pinning

Pin	Description	Simplified outline	Symbol
1	gate 1 (a)	<p>001aaa706</p>	<p>sym033</p>
2	gate 2		
3	gate 1 (b)		
4	drain (b)		
5	source		
6	drain (a)		

3. Ordering information

Table 3. Ordering information

Type number	Package		
	Name	Description	Version
BF1205C	-	plastic surface mounted package; 6 leads	SOT363

4. Marking

Table 4. Marking

Type number	Marking code ^[1]
BF1205C	M6*

- [1] * = p or -: made in Hong Kong.
 * = t: made in Malaysia.
 * = W: made in China.

5. Limiting values

Table 5. Limiting values

In accordance with the Absolute Maximum Rating System (IEC 60134).

Symbol	Parameter	Conditions	Min	Max	Unit
Per MOS-FET					
V_{DS}	drain-source voltage		-	6	V
I_D	drain current (DC)		-	30	mA
I_{G1}	gate 1 current		-	±10	mA
I_{G2}	gate 2 current		-	±10	mA
P_{tot}	total power dissipation	$T_{sp} \leq 107\text{ °C}$ ^[1]	-	180	mW
T_{stg}	storage temperature		-65	+150	°C
T_j	junction temperature		-	150	°C

- [1] T_{sp} is the temperature at the soldering point of the source lead.

6. Thermal characteristics

Table 6. Thermal characteristics

Symbol	Parameter	Conditions	Typ	Unit
$R_{th(j-s)}$	thermal resistance from junction to soldering point		240	K/W

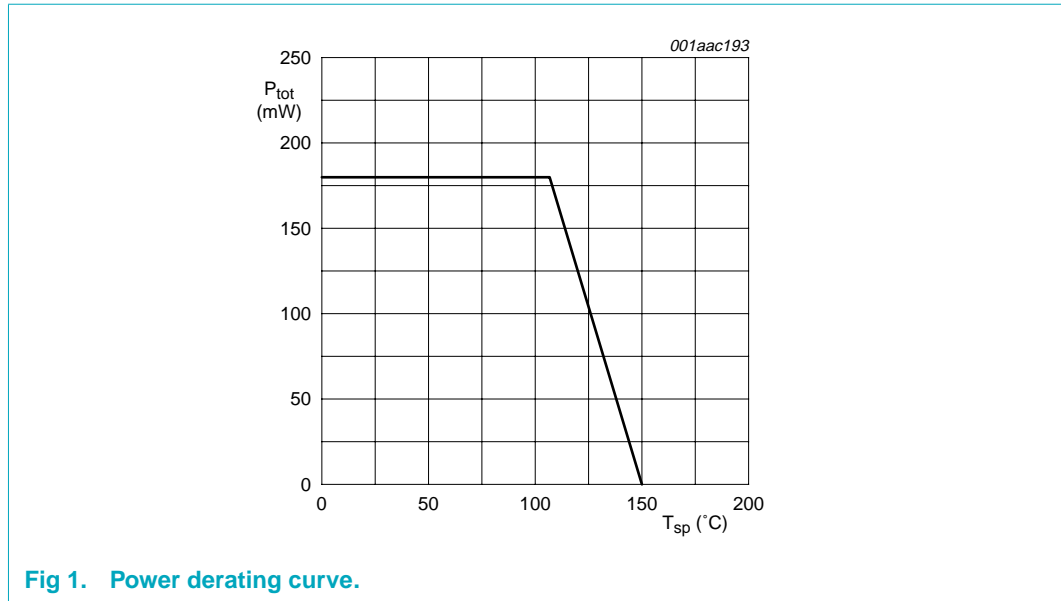

Fig 1. Power derating curve.

7. Static characteristics

Table 7. Static characteristics

T_j = 25 °C.

Symbol	Parameter	Conditions	Min	Typ	Max	Unit
Per MOS-FET; unless otherwise specified						
V _{(BR)DSS}	drain-source breakdown voltage	V _{G1-S} = V _{G2-S} = 0 V; I _D = 10 μA				
		amplifier a	6	-	-	V
		amplifier b	6	-	-	V
V _{(BR)G1-SS}	gate 1-source breakdown voltage	V _{GS} = V _{DS} = 0 V; I _{G1-S} = 10 mA	6	-	10	V
V _{(BR)G2-SS}	gate 2-source breakdown voltage	V _{GS} = V _{DS} = 0 V; I _{G2-S} = 10 mA	6	-	10	V
V _{(F)S-G1}	forward source-gate 1 voltage	V _{G2-S} = V _{DS} = 0 V; I _{S-G1} = 10 mA	0.5	-	1.5	V
V _{(F)S-G2}	forward source-gate 2 voltage	V _{G1-S} = V _{DS} = 0 V; I _{S-G2} = 10 mA	0.5	-	1.5	V
V _{G1-S(th)}	gate 1-source threshold voltage	V _{DS} = 5 V; V _{G2-S} = 4 V; I _D = 100 μA	0.3	-	1.0	V
V _{G2-S(th)}	gate 2-source threshold voltage	V _{DS} = 5 V; V _{G1-S} = 5 V; I _D = 100 μA	0.4	-	1.0	V
I _{DSX}	drain-source current	V _{G2-S} = 4 V; V _{DS(b)} = 5 V; R _{G1} = 150 kΩ				
		amplifier a; V _{DS(a)} = 5 V	[1] 14	-	24	mA
		amplifier b	[2] 9	-	17	mA
I _{G1-S}	gate 1 cut-off current	V _{G2-S} = V _{DS(a)} = 0 V				
		amplifier a; V _{G1-S(a)} = 5 V; I _{D(b)} = 0 A	-	-	50	nA
		amplifier b; V _{G1-S(b)} = 5 V; V _{DS(b)} = 0 V	-	-	50	nA
I _{G2-S}	gate 2 cut-off current	V _{G2-S} = 4 V; V _{G1-S(a)} = V _{DS(a)} = V _{DS(b)} = 0 V; V _{G1-S(b)} = 0 V;	-	-	20	nA

[1] R_{G1} connects gate 1 (b) to V_{GG} = 0 V (see Figure 3).

[2] R_{G1} connects gate 1 (b) to V_{GG} = 5 V (see Figure 3).

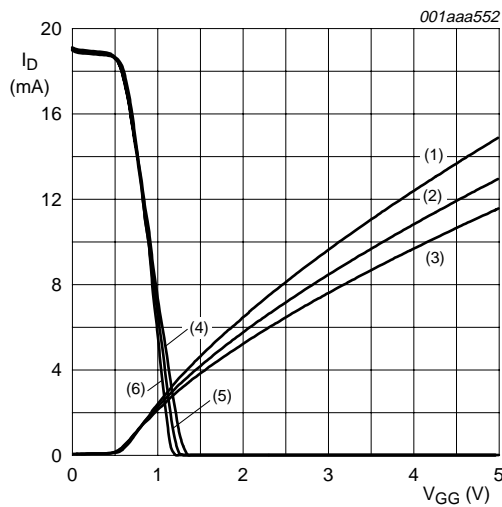

- (1) $I_{D(b)}$; $R_{G1} = 120\text{ k}\Omega$.
- (2) $I_{D(b)}$; $R_{G1} = 150\text{ k}\Omega$.
- (3) $I_{D(b)}$; $R_{G1} = 180\text{ k}\Omega$.
- (4) $I_{D(a)}$; $R_{G1} = 180\text{ k}\Omega$.
- (5) $I_{D(a)}$; $R_{G1} = 150\text{ k}\Omega$.
- (6) $I_{D(a)}$; $R_{G1} = 120\text{ k}\Omega$.

Fig 2. Drain currents of MOS-FET a and b as function of V_{GG} .

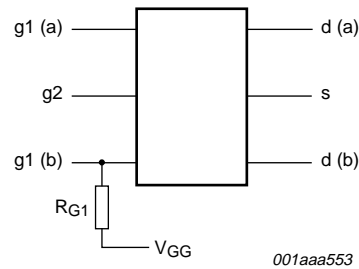

$V_{GG} = 5\text{ V}$: amplifier a is off; amplifier b is on
 $V_{GG} = 0\text{ V}$: amplifier a is on; amplifier b is off.

Fig 3. Functional diagram.

8. Dynamic characteristics

8.1 Dynamic characteristics for amplifier a

Table 8. Dynamic characteristics for amplifier a[1]

Common source; $T_{amb} = 25\text{ }^\circ\text{C}$; $V_{G2-S} = 4\text{ V}$; $V_{DS} = 5\text{ V}$; $I_D = 19\text{ mA}$.

Symbol	Parameter	Conditions	Min	Typ	Max	Unit
$ y_{fs} $	forward transfer admittance	$T_j = 25\text{ }^\circ\text{C}$	26	31	41	mS
C_{ig1-ss}	input capacitance at gate 1	$f = 1\text{ MHz}$	-	2.2	2.7	pF
C_{ig2-ss}	input capacitance at gate 2	$f = 1\text{ MHz}$	-	3.0	-	pF
C_{oss}	output capacitance	$f = 1\text{ MHz}$	-	0.9	-	pF
C_{rss}	reverse transfer capacitance	$f = 1\text{ MHz}$	-	20	-	fF
G_{tr}	power gain	$B_S = B_{S(opt)}$; $B_L = B_{L(opt)}$				
		$f = 200\text{ MHz}$; $G_S = 2\text{ mS}$; $G_L = 0.5\text{ mS}$	31	35	39	dB
		$f = 400\text{ MHz}$; $G_S = 2\text{ mS}$; $G_L = 1\text{ mS}$	26	30	34	dB
		$f = 800\text{ MHz}$; $G_S = 3.3\text{ mS}$; $G_L = 1\text{ mS}$	21	25	29	dB
NF	noise figure	$f = 11\text{ MHz}$; $G_S = 20\text{ mS}$; $B_S = 0\text{ S}$	-	3.0	-	dB
		$f = 400\text{ MHz}$; $Y_S = Y_{S(opt)}$	-	1.3	1.9	dB
		$f = 800\text{ MHz}$; $Y_S = Y_{S(opt)}$	-	1.4	2.1	dB

Table 8. Dynamic characteristics for amplifier a [1] ...continued
Common source; $T_{amb} = 25\text{ }^{\circ}\text{C}$; $V_{G2-S} = 4\text{ V}$; $V_{DS} = 5\text{ V}$; $I_D = 19\text{ mA}$.

Symbol	Parameter	Conditions	Min	Typ	Max	Unit
X_{mod}	cross-modulation	input level for $k = 1\%$; $f_w = 50\text{ MHz}$; $f_{unw} = 60\text{ MHz}$ [2]				
		at 0 dB AGC	90	-	-	dB μ V
		at 10 dB AGC	-	90	-	dB μ V
		at 20 dB AGC	-	99	-	dB μ V
		at 40 dB AGC	100	105	-	dB μ V

[1] For the MOS-FET not in use: $V_{G1-S(b)} = 0\text{ V}$; $V_{DS(b)} = 0\text{ V}$.

[2] Measured in Figure 33 test circuit.

8.1.1 Graphs for amplifier a

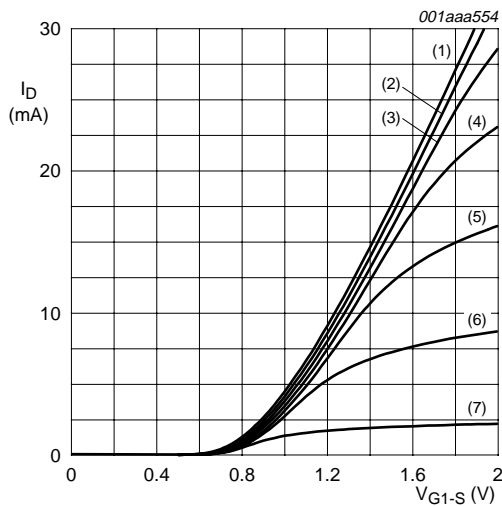

- (1) $V_{G2-S} = 4\text{ V}$.
 - (2) $V_{G2-S} = 3.5\text{ V}$.
 - (3) $V_{G2-S} = 3\text{ V}$.
 - (4) $V_{G2-S} = 2.5\text{ V}$.
 - (5) $V_{G2-S} = 2\text{ V}$.
 - (6) $V_{G2-S} = 1.5\text{ V}$.
 - (7) $V_{G2-S} = 1\text{ V}$.
- $V_{DS(a)} = 5\text{ V}$; $V_{G1-S(b)} = V_{DS(b)} = 0\text{ V}$; $T_j = 25\text{ }^{\circ}\text{C}$.

Fig 4. Transfer characteristics; typical values.

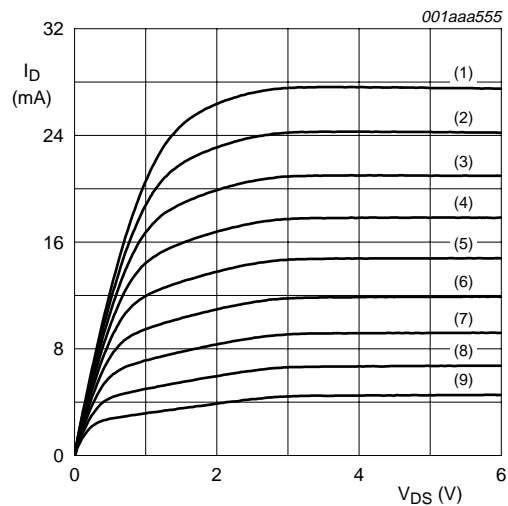

- (1) $V_{G1-S(a)} = 1.8\text{ V}$.
 - (2) $V_{G1-S(a)} = 1.7\text{ V}$.
 - (3) $V_{G1-S(a)} = 1.6\text{ V}$.
 - (4) $V_{G1-S(a)} = 1.5\text{ V}$.
 - (5) $V_{G1-S(a)} = 1.4\text{ V}$.
 - (6) $V_{G1-S(a)} = 1.3\text{ V}$.
 - (7) $V_{G1-S(a)} = 1.2\text{ V}$.
 - (8) $V_{G1-S(a)} = 1.1\text{ V}$.
 - (9) $V_{G1-S(a)} = 1\text{ V}$.
- $V_{G2-S} = 4\text{ V}$; $V_{G1-S(b)} = V_{DS(b)} = 0\text{ V}$; $T_j = 25\text{ }^{\circ}\text{C}$.

Fig 5. Output characteristics; typical values.

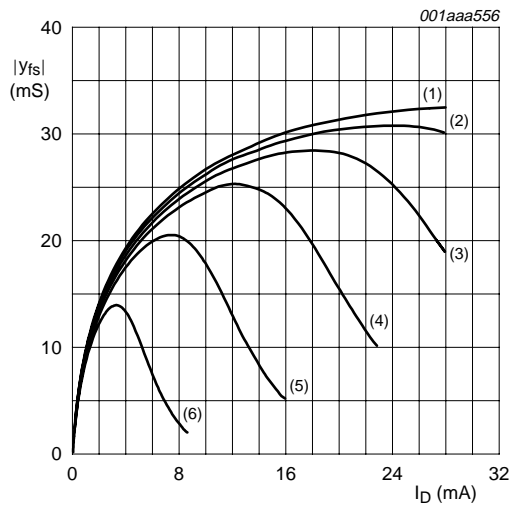

- (1) $V_{G2-S} = 4 \text{ V}$.
 - (2) $V_{G2-S} = 3.5 \text{ V}$.
 - (3) $V_{G2-S} = 3 \text{ V}$.
 - (4) $V_{G2-S} = 2.5 \text{ V}$.
 - (5) $V_{G2-S} = 2 \text{ V}$.
 - (6) $V_{G2-S} = 1.5 \text{ V}$.
- $V_{DS(a)} = 5 \text{ V}; V_{G1-S(b)} = V_{DS(b)} = 0 \text{ V}; T_j = 25 \text{ }^\circ\text{C}$.

Fig 6. Forward transfer admittance as a function of drain current; typical values.

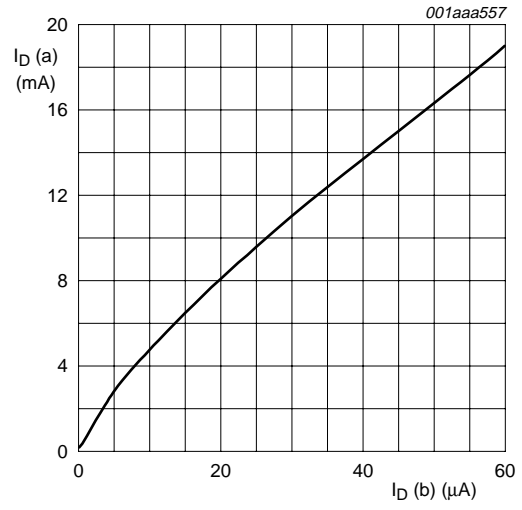

- $V_{DS(a)} = 5 \text{ V}; V_{G2-S} = 4 \text{ V}; V_{DS(b)} = 5 \text{ V};$
 $V_{G1-S(b)} = 0 \text{ V}; T_j = 25 \text{ }^\circ\text{C}$.

Fig 7. Drain current as a function of internal G1 current (current in pin drain (b) if MOS-FET (b) is switched off); typical values.

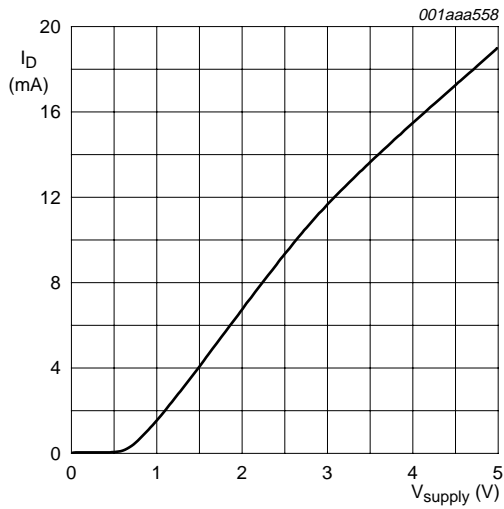

$V_{DS(a)} = V_{DS(b)} = V_{supply}$, $V_{G2-S} = 4\text{ V}$, $T_j = 25\text{ }^\circ\text{C}$,
 $R_{G1(b)} = 150\text{ k}\Omega$ (connected to ground); see [Figure 3](#).

Fig 8. Drain current of amplifier a as a function of supply voltage of a and b amplifier; typical values.

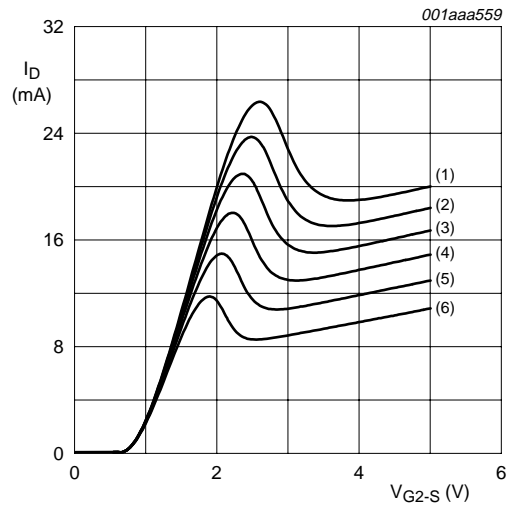

(1) $V_{DS(b)} = 5\text{ V}$.
 (2) $V_{DS(b)} = 4.5\text{ V}$.
 (3) $V_{DS(b)} = 4\text{ V}$.
 (4) $V_{DS(b)} = 3.5\text{ V}$.
 (5) $V_{DS(b)} = 3\text{ V}$.
 (6) $V_{DS(b)} = 2.5\text{ V}$.
 $V_{DS(a)} = 5\text{ V}$; $V_{G1-S(b)} = 0\text{ V}$; gate 1 (a) = open;
 $T_j = 25\text{ }^\circ\text{C}$.

Fig 9. Drain current as a function of gate 2 and drain supply voltage; typical values.

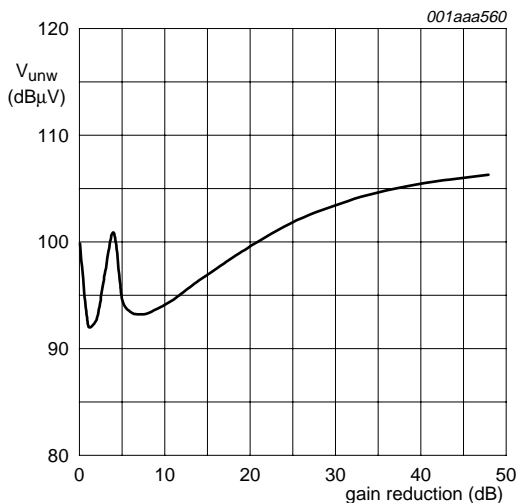

$V_{DS(a)} = V_{DS(b)} = 5\text{ V}$; $V_{G1-S(b)} = 0\text{ V}$; $f_w = 50\text{ MHz}$;
 $f_{unw} = 60\text{ MHz}$; $T_{amb} = 25\text{ }^\circ\text{C}$; see [Figure 33](#).

Fig 10. Unwanted voltage for 1 % cross-modulation as a function of gain reduction; typical values.

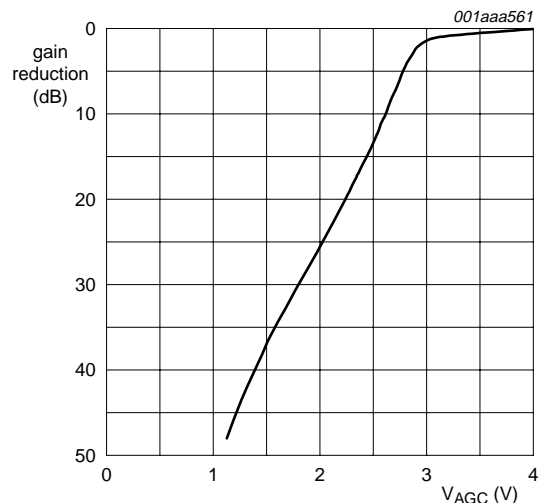

$V_{DS(a)} = V_{DS(b)} = 5\text{ V}$; $V_{G1-S(b)} = 0\text{ V}$; $f = 50\text{ MHz}$; see [Figure 33](#).

Fig 11. Gain reduction as a function of AGC voltage; typical values.

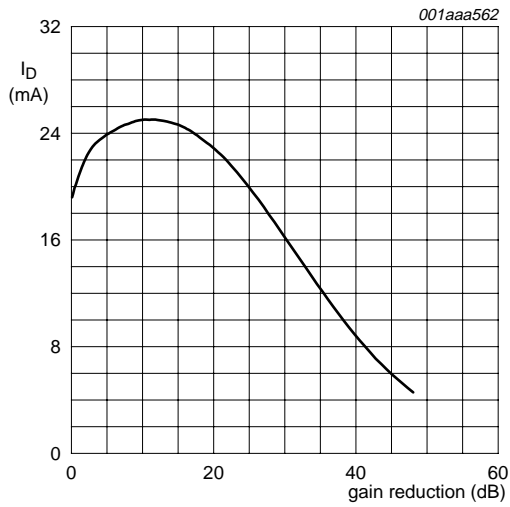

$V_{DS(a)} = V_{DS(b)} = 5\text{ V}$; $V_{G1-S(b)} = 0\text{ V}$; $f = 50\text{ MHz}$;
 $T_{amb} = 25\text{ }^\circ\text{C}$; see [Figure 33](#).

Fig 12. Drain current as a function of gain reduction; typical values.

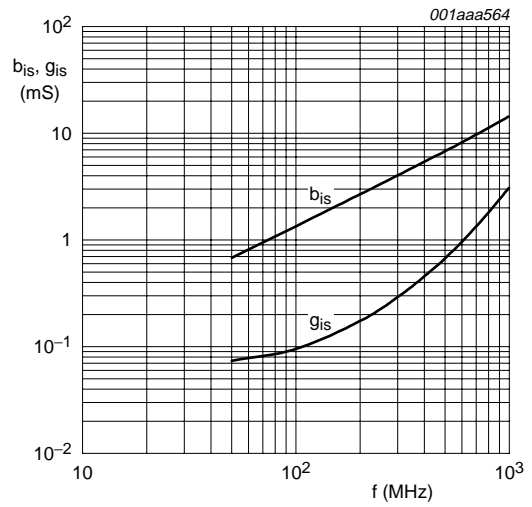

$V_{DS(a)} = 5\text{ V}$; $V_{G2-S(a)} = 4\text{ V}$; $V_{DS(b)} = V_{G1-S(b)} = 0\text{ V}$;
 $I_{D(a)} = 19\text{ mA}$.

Fig 13. Input admittance as a function of frequency; typical values.

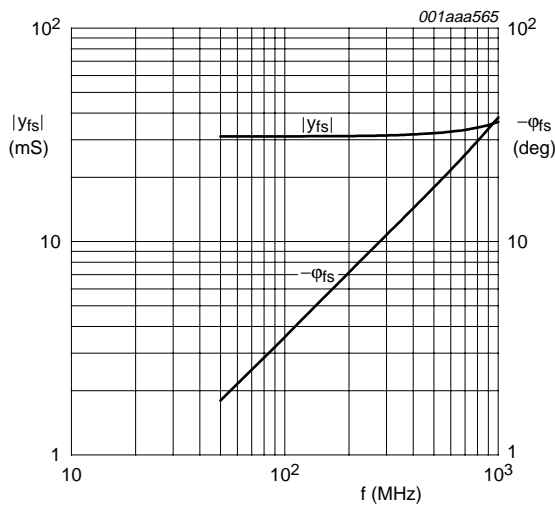

$V_{DS(a)} = 5\text{ V}$; $V_{G2-S(a)} = 4\text{ V}$; $V_{DS(b)} = V_{G1-S(b)} = 0\text{ V}$;
 $I_{D(a)} = 19\text{ mA}$.

Fig 14. Forward transfer admittance and phase as a function of frequency; typical values.

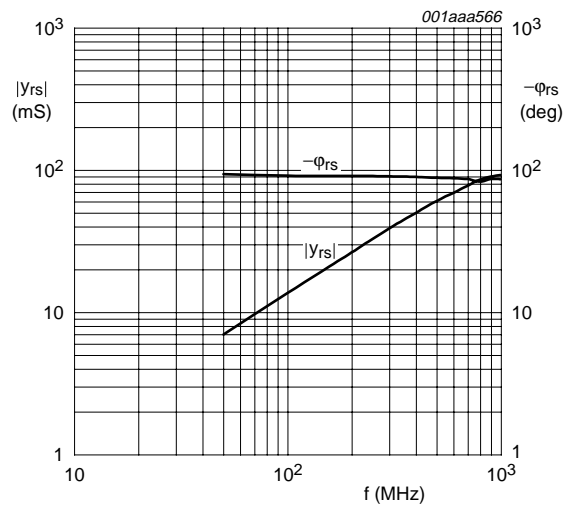

$V_{DS(a)} = 5\text{ V}$; $V_{G2-S(a)} = 4\text{ V}$; $V_{DS(b)} = V_{G1-S(b)} = 0\text{ V}$;
 $I_{D(a)} = 19\text{ mA}$.

Fig 15. Reverse transfer admittance and phase as a function of frequency; typical values.

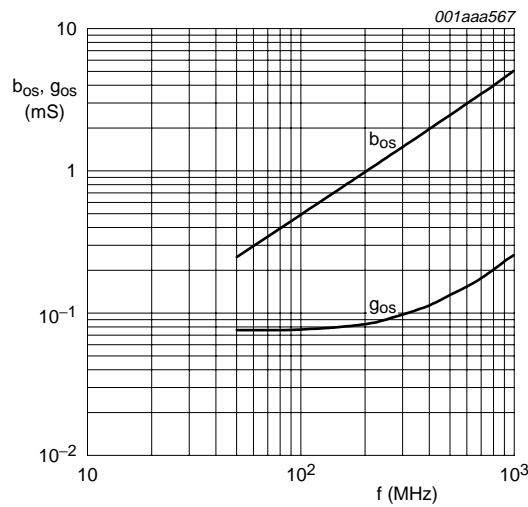

$V_{DS(a)} = 5\text{ V}$; $V_{G2-S(a)} = 4\text{ V}$; $V_{DS(b)} = V_{G1-S(b)} = 0\text{ V}$; $I_{D(a)} = 19\text{ mA}$.

Fig 16. Output admittance as a function of frequency; typical values.

8.1.2 Scattering parameters for amplifier a

Table 9. Scattering parameters for amplifier a

$V_{DS(a)} = 5\text{ V}$; $V_{G2-S} = 4\text{ V}$; $I_{D(a)} = 19\text{ mA}$; $V_{DS(b)} = 0\text{ V}$; $V_{G-1S(b)} = 0\text{ V}$; $T_{amb} = 25\text{ }^\circ\text{C}$.

f (MHz)	S ₁₁		S ₂₁		S ₁₂		S ₂₂	
	Magnitude ratio	Angle (deg)	Magnitude ratio	Angle (deg)	Magnitude ratio	Angle (deg)	Magnitude ratio	Angle (deg)
50	0.992	-3.91	3.07	175.56	0.0007	83.61	0.992	-1.47
100	0.990	-7.76	3.06	171.18	0.0017	83.19	0.992	-2.93
200	0.982	-15.42	3.04	162.42	0.0026	78.19	0.990	-5.84
300	0.971	-22.99	3.01	153.79	0.0037	73.75	0.988	-8.71
400	0.956	-30.52	2.96	145.22	0.0047	69.82	0.985	-11.59
500	0.938	-37.83	2.90	136.78	0.0055	66.12	0.982	-14.48
600	0.917	-45.14	2.83	128.46	0.0061	62.11	0.979	-17.31
700	0.893	-52.31	2.76	120.20	0.0065	58.86	0.975	-20.14
800	0.867	-59.47	2.69	111.98	0.0068	58.28	0.972	-22.98
900	0.838	-66.23	2.60	103.90	0.0067	50.64	0.968	-25.85
1000	0.807	-73.10	2.52	95.875	0.0065	47.28	0.966	-28.74

8.1.3 Noise data for amplifier a

Table 10. Noise data for amplifier a

$V_{DS(a)} = 5\text{ V}$; $V_{G2-S} = 4\text{ V}$; $I_{D(a)} = 19\text{ mA}$; $V_{DS(b)} = 0\text{ V}$; $V_{G-1S(b)} = 0\text{ V}$; $T_{amb} = 25\text{ }^\circ\text{C}$.

f (MHz)	F _{min} (dB)	Γ _{opt}		r _n (Ω)
		ratio	(deg)	
400	1.3	0.718	16.06	0.683
800	1.4	0.677	37.59	0.681

8.2 Dynamic characteristics for amplifier b

Table 11. Dynamic characteristics for amplifier b

Common source; $T_{amb} = 25\text{ °C}$; $V_{G2-S} = 4\text{ V}$; $V_{DS} = 5\text{ V}$; $I_D = 13\text{ mA}$.

Symbol	Parameter	Conditions	Min	Typ	Max	Unit
$ y_{fs} $	forward transfer admittance	$T_j = 25\text{ °C}$	28	33	43	mS
C_{ig1-ss}	input capacitance at gate 1	$f = 1\text{ MHz}$	-	2.0	2.5	pF
C_{ig2-ss}	input capacitance at gate 2	$f = 1\text{ MHz}$	-	3.4	-	pF
C_{oss}	output capacitance	$f = 1\text{ MHz}$	-	0.85	-	pF
C_{rss}	reverse transfer capacitance	$f = 1\text{ MHz}$	-	20	-	fF
G_{tr}	power gain	$B_S = B_{S(opt)}$; $B_L = B_{L(opt)}$	[1]			
		$f = 200\text{ MHz}$; $G_S = 2\text{ mS}$; $G_L = 0.5\text{ mS}$	31	35	39	dB
		$f = 400\text{ MHz}$; $G_S = 2\text{ mS}$; $G_L = 1\text{ mS}$	28	32	36	dB
		$f = 800\text{ MHz}$; $G_S = 3.3\text{ mS}$; $G_L = 1\text{ mS}$	24	28	32	dB
NF	noise figure	$f = 11\text{ MHz}$; $G_S = 20\text{ mS}$; $B_S = 0\text{ S}$	-	5	-	dB
		$f = 400\text{ MHz}$; $Y_S = Y_{S(opt)}$	-	1.3	1.9	dB
		$f = 800\text{ MHz}$; $Y_S = Y_{S(opt)}$	-	1.4	2.1	dB
X_{mod}	cross-modulation	input level for $k = 1\%$; $f_w = 50\text{ MHz}$; $f_{unw} = 60\text{ MHz}$	[2]			
		at 0 dB AGC	90	-	-	dB μ V
		at 10 dB AGC	-	88	-	dB μ V
		at 20 dB AGC	-	94	-	dB μ V
		at 40 dB AGC	100	103	-	dB μ V

[1] For the MOS-FET not in use: $V_{G1-S(a)} = 0\text{ V}$; $V_{DS(a)} = 0\text{ V}$.[2] Measured in [Figure 34](#) test circuit.

8.2.1 Graphs for amplifier b

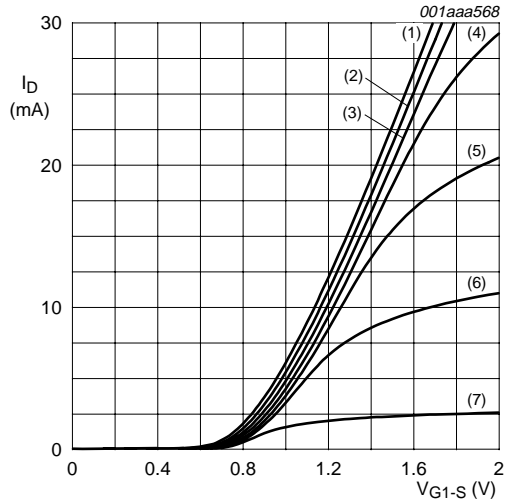

- (1) $V_{G2-S} = 4$ V.
- (2) $V_{G2-S} = 3.5$ V.
- (3) $V_{G2-S} = 3$ V.
- (4) $V_{G2-S} = 2.5$ V.
- (5) $V_{G2-S} = 2$ V.
- (6) $V_{G2-S} = 1.5$ V.
- (7) $V_{G2-S} = 1$ V.

$V_{DS(b)} = 5$ V; $V_{DS(a)} = V_{G1-S(a)} = 0$ V; $T_j = 25$ °C.

Fig 17. Transfer characteristics; typical values.

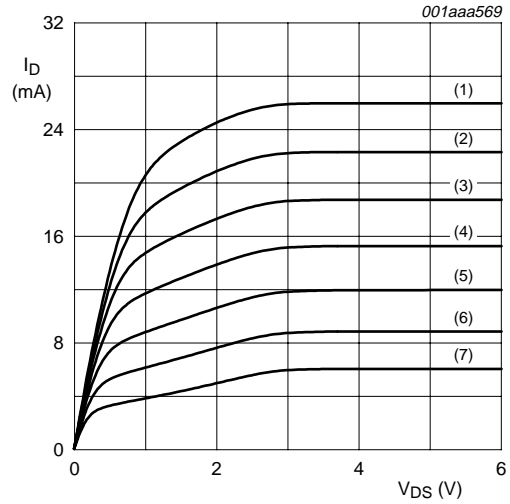

- (1) $V_{G1-S(b)} = 1.6$ V.
- (2) $V_{G1-S(b)} = 1.5$ V.
- (3) $V_{G1-S(b)} = 1.4$ V.
- (4) $V_{G1-S(b)} = 1.3$ V.
- (5) $V_{G1-S(b)} = 1.2$ V.
- (6) $V_{G1-S(b)} = 1.1$ V.
- (7) $V_{G1-S(b)} = 1$ V.

$V_{G2-S} = 4$ V; $V_{DS(a)} = V_{G1-S(a)} = 0$ V; $T_j = 25$ °C.

Fig 18. Output characteristics; typical values.

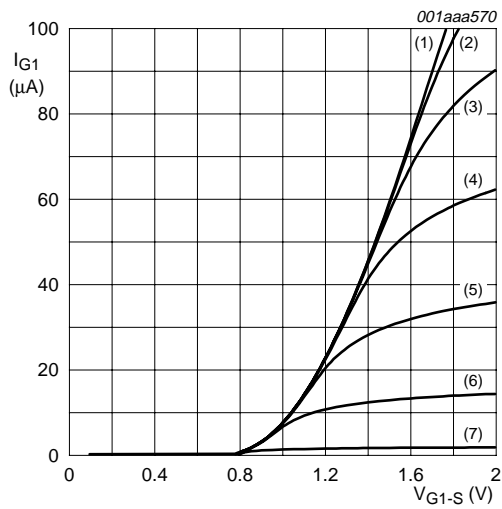

(1) $V_{G2-S} = 4\text{ V}$.
 (2) $V_{G2-S} = 3.5\text{ V}$.
 (3) $V_{G2-S} = 3\text{ V}$.
 (4) $V_{G2-S} = 2.5\text{ V}$.
 (5) $V_{G2-S} = 2\text{ V}$.
 (6) $V_{G2-S} = 1.5\text{ V}$.
 (7) $V_{G2-S} = 1\text{ V}$.
 $V_{DS(b)} = 5\text{ V}$; $V_{DS(a)} = V_{G1-S(a)} = 0\text{ V}$; $T_j = 25\text{ }^\circ\text{C}$.

Fig 19. Gate 1 current as a function of gate 1 voltage; typical values.

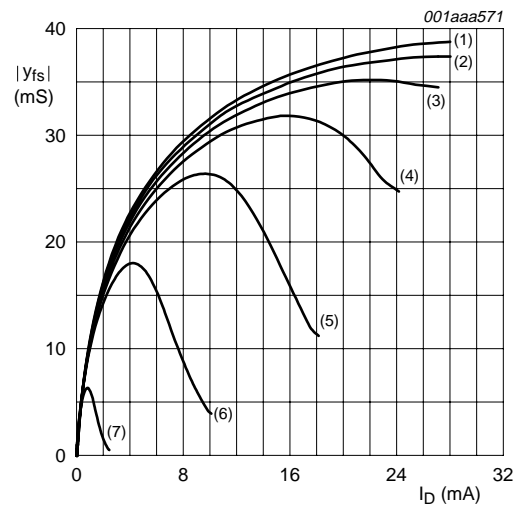

(1) $V_{G2-S} = 4\text{ V}$.
 (2) $V_{G2-S} = 3.5\text{ V}$.
 (3) $V_{G2-S} = 3\text{ V}$.
 (4) $V_{G2-S} = 2.5\text{ V}$.
 (5) $V_{G2-S} = 2\text{ V}$.
 (6) $V_{G2-S} = 1.5\text{ V}$.
 (7) $V_{G2-S} = 1\text{ V}$.
 $V_{DS(b)} = 5\text{ V}$; $V_{DS(a)} = V_{G1-S(a)} = 0\text{ V}$; $T_j = 25\text{ }^\circ\text{C}$.

Fig 20. Forward transfer admittance as a function of drain current; typical values.

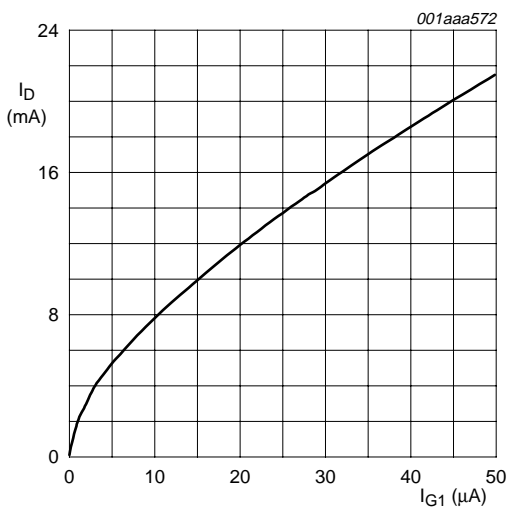

$V_{DS(b)} = 5\text{ V}$; $V_{G2-S} = 4\text{ V}$; $V_{DS(a)} = V_{G1-S(a)} = 0\text{ V}$;
 $T_j = 25\text{ }^\circ\text{C}$.

Fig 21. Drain current as a function of gate 1 current; typical values.

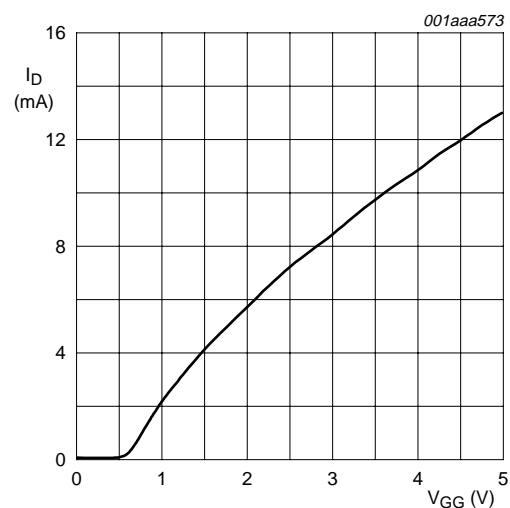

$V_{DS(b)} = 5\text{ V}$; $V_{G2-S} = 4\text{ V}$; $V_{DS(a)} = V_{G1-S(a)} = 0\text{ V}$;
 $T_j = 25\text{ }^\circ\text{C}$; $R_{G1(b)} = 150\text{ k}\Omega$ (connected to V_{GG}); see Figure 3.

Fig 22. Drain current as a function of gate 1 supply voltage (V_{GG}); typical values.

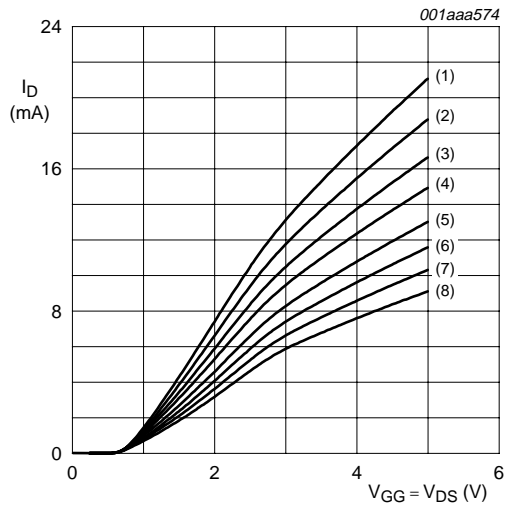

- (1) $R_{G1(b)} = 68 \text{ k}\Omega$.
- (2) $R_{G1(b)} = 82 \text{ k}\Omega$.
- (3) $R_{G1(b)} = 100 \text{ k}\Omega$.
- (4) $R_{G1(b)} = 120 \text{ k}\Omega$.
- (5) $R_{G1(b)} = 150 \text{ k}\Omega$.
- (6) $R_{G1(b)} = 180 \text{ k}\Omega$.
- (7) $R_{G1(b)} = 220 \text{ k}\Omega$.
- (8) $R_{G1(b)} = 270 \text{ k}\Omega$.

$V_{G2-S} = 4 \text{ V}$; $V_{DS(a)} = V_{G1-S(a)} = 0 \text{ V}$; $T_j = 25 \text{ }^\circ\text{C}$;
 $R_{G1(b)}$ is connected to V_{GG} ; see [Figure 3](#).

Fig 23. Drain current as a function of gate 1 (V_{GG}), drain supply voltage and value of R_{G1} ; typical values.

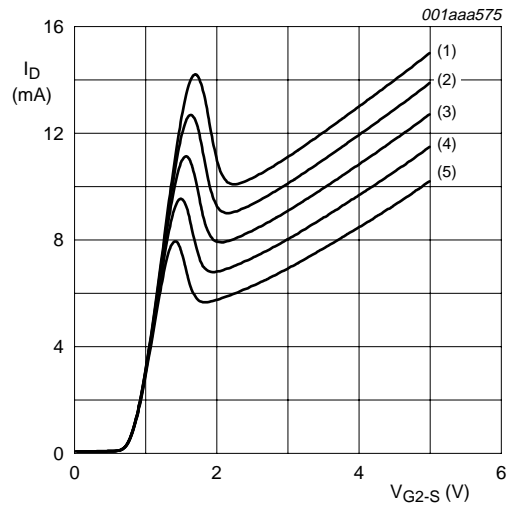

- (1) $V_{GG} = 5.0 \text{ V}$.
- (2) $V_{GG} = 4.5 \text{ V}$.
- (3) $V_{GG} = 4.0 \text{ V}$.
- (4) $V_{GG} = 3.5 \text{ V}$.
- (5) $V_{GG} = 3.0 \text{ V}$.

$V_{DS(b)} = 5 \text{ V}$; $V_{DS(a)} = V_{G1-S(a)} = 0 \text{ V}$; $T_j = 25 \text{ }^\circ\text{C}$;
 $R_{G1(b)} = 150 \text{ k}\Omega$ (connected to V_{GG}); see [Figure 3](#).

Fig 24. Drain current as a function of gate 2 voltage; typical values.

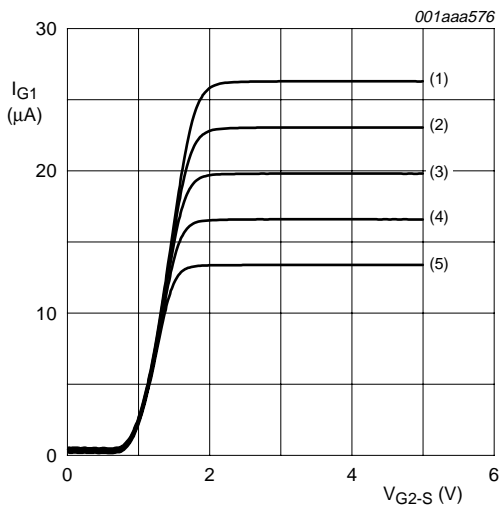

(1) $V_{GG} = 5.0$ V.
 (2) $V_{GG} = 4.5$ V.
 (3) $V_{GG} = 4.0$ V.
 (4) $V_{GG} = 3.5$ V.
 (5) $V_{GG} = 3.0$ V.
 $V_{DS(b)} = 5$ V; $V_{DS(a)} = V_{G1-S(a)} = 0$ V; $T_j = 25$ °C;
 $R_{G1(b)} = 150$ k Ω (connected to V_{GG}); see [Figure 3](#).

Fig 25. Gate 1 current as a function of gate 2 voltage; typical values.

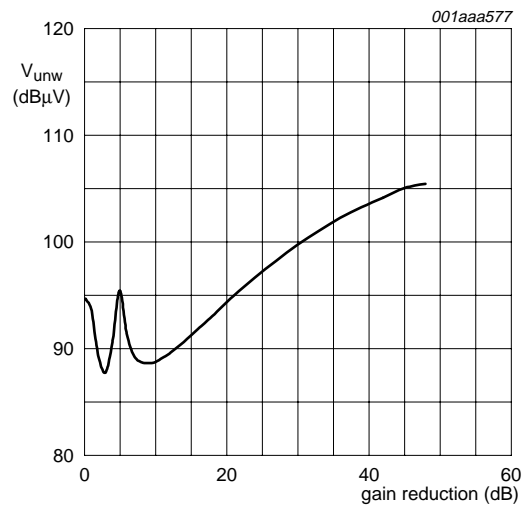

$V_{DS(b)} = 5$ V; $V_{GG} = 5$ V; $V_{DS(a)} = V_{G1-S(a)} = 0$ V;
 $R_{G1(b)} = 150$ k Ω (connected to V_{GG}); $f_w = 50$ MHz;
 $f_{unw} = 60$ MHz; $T_{amb} = 25$ °C; see [Figure 34](#).

Fig 26. Unwanted voltage for 1 % cross-modulation as a function of gain reduction; typical values.

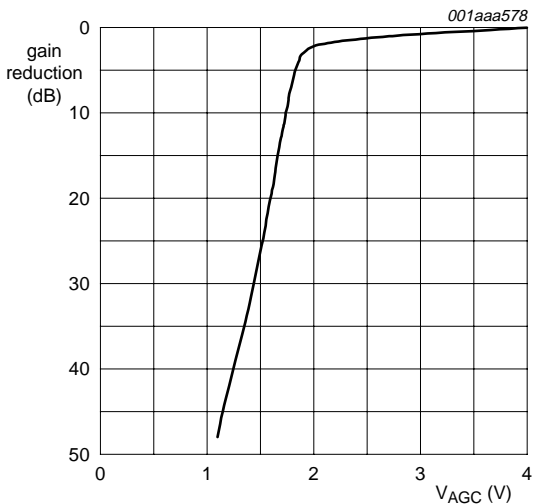

$V_{DS(b)} = 5$ V; $V_{GG} = 5$ V; $V_{DS(a)} = V_{G1-S(a)} = 0$ V;
 $R_{G1(b)} = 150$ k Ω (connected to V_{GG}); $f = 50$ MHz;
 $T_{amb} = 25$ °C; see [Figure 34](#).

Fig 27. Typical gain reduction as a function of AGC voltage.

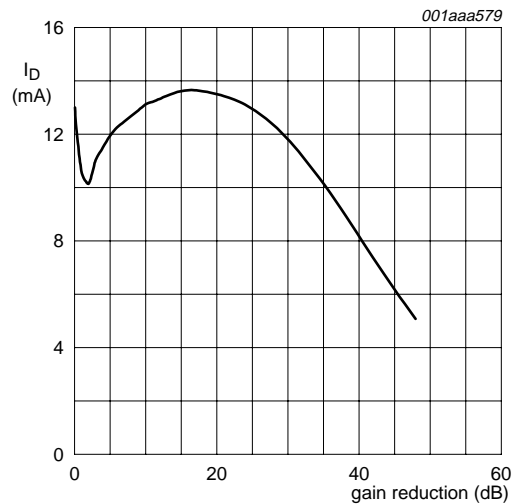

$V_{DS(b)} = 5$ V; $V_{GG} = 5$ V; $V_{DS(a)} = V_{G1-S(a)} = 0$ V;
 $R_{G1(b)} = 150$ k Ω (connected to V_{GG}); $f = 50$ MHz;
 $T_{amb} = 25$ °C; see [Figure 34](#).

Fig 28. Drain current as a function of gain reduction; typical values.

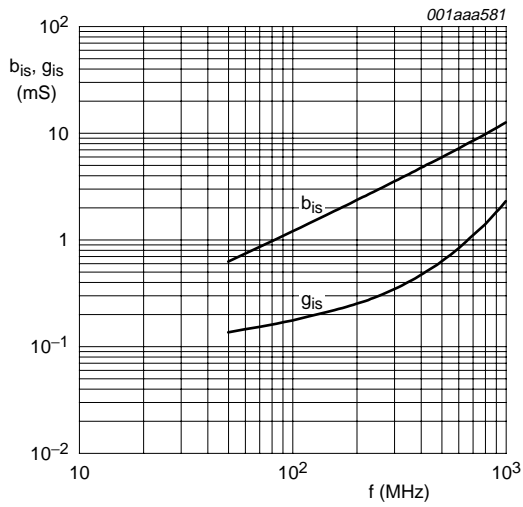

$V_{DS(b)} = 5\text{ V}; V_{G2-S} = 4\text{ V}; V_{DS(a)} = V_{G1-S(a)} = 0\text{ V}; I_{D(b)} = 13\text{ mA}.$

Fig 29. Input admittance as a function of frequency; typical values.

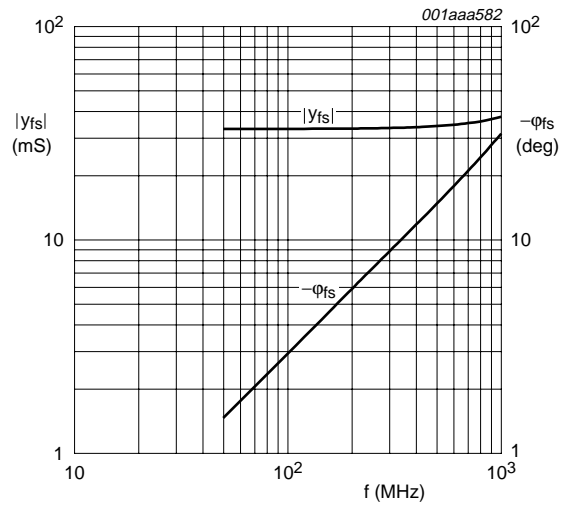

$V_{DS(b)} = 5\text{ V}; V_{G2-S} = 4\text{ V}; V_{DS(a)} = V_{G1-S(a)} = 0\text{ V}; I_{D(b)} = 13\text{ mA}.$

Fig 30. Forward transfer admittance and phase as a function of frequency; typical values.

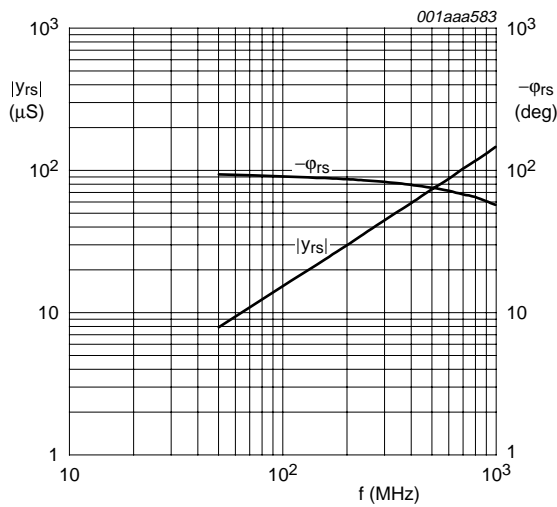

$V_{DS(b)} = 5\text{ V}; V_{G2-S} = 4\text{ V}; V_{DS(a)} = V_{G1-S(a)} = 0\text{ V}; I_{D(b)} = 13\text{ mA}.$

Fig 31. Reverse transfer admittance and phase as a function of frequency; typical values.

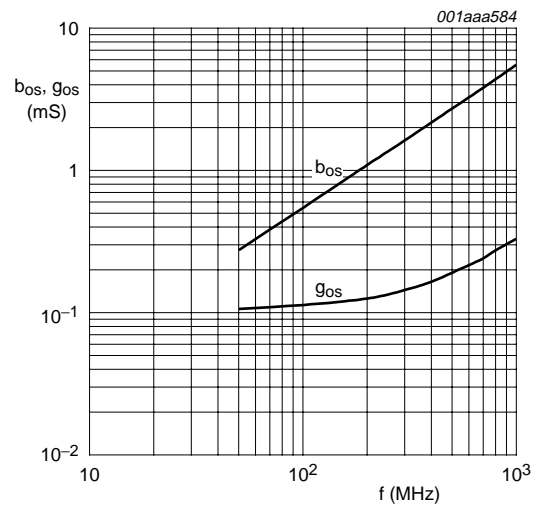

$V_{DS(b)} = 5\text{ V}; V_{G2-S} = 4\text{ V}; V_{DS(a)} = V_{G1-S(a)} = 0\text{ V}; I_{D(b)} = 13\text{ mA}.$

Fig 32. Output admittance as a function of frequency; typical values.

8.2.2 Scattering parameters for amplifier b

Table 12. Scattering parameters for amplifier b

$V_{DS(b)} = 5\text{ V}$; $V_{G2-S} = 4\text{ V}$; $I_{D(b)} = 13\text{ mA}$; $V_{DS(a)} = 0\text{ V}$; $V_{G1-S(a)} = 0\text{ V}$; $T_{amb} = 25\text{ }^{\circ}\text{C}$.

f (MHz)	S ₁₁		S ₂₁		S ₁₂		S ₂₂	
	Magnitude ratio	Angle (deg)	Magnitude ratio	Angle (deg)	Magnitude ratio	Angle (deg)	Magnitude ratio	Angle (deg)
50	0.986	-3.66	3.26	175.93	0.0008	84.23	0.988	-1.65
100	0.982	-7.01	3.24	172.04	0.0015	84.91	0.988	-3.27
200	0.975	-13.71	3.22	164.24	0.0029	83.96	0.986	-6.50
300	0.966	-20.36	3.19	156.53	0.0042	82.86	0.984	-9.69
400	0.955	-27.04	3.15	148.86	0.0055	81.88	0.982	-12.88
500	0.943	-33.62	3.10	141.24	0.0066	80.92	0.978	-16.07
600	0.927	-40.16	3.05	133.70	0.0076	80.15	0.975	-19.21
700	0.909	-46.70	2.99	126.13	0.0086	79.68	0.972	-22.35
800	0.891	-52.07	2.92	118.64	0.0094	78.28	0.968	-25.52
900	0.868	-59.48	2.84	111.09	0.0100	78.28	0.965	-28.65
1000	0.846	-65.86	2.77	103.58	0.0107	78.15	0.961	-31.85

8.2.3 Noise data for amplifier b

Table 13. Noise data for amplifier b

$V_{DS(b)} = 5\text{ V}$; $V_{G2-S} = 4\text{ V}$; $I_{D(b)} = 13\text{ mA}$; $V_{DS(a)} = 0\text{ V}$; $V_{G1-S(a)} = 0\text{ V}$; $T_{amb} = 25\text{ }^{\circ}\text{C}$.

f (MHz)	F _{min} (dB)	Γ _{opt}		r _n (Ω)
		ratio	(deg)	
400	1.3	0.695	13.11	0.694
800	1.4	0.674	32.77	0.674

9. Test information

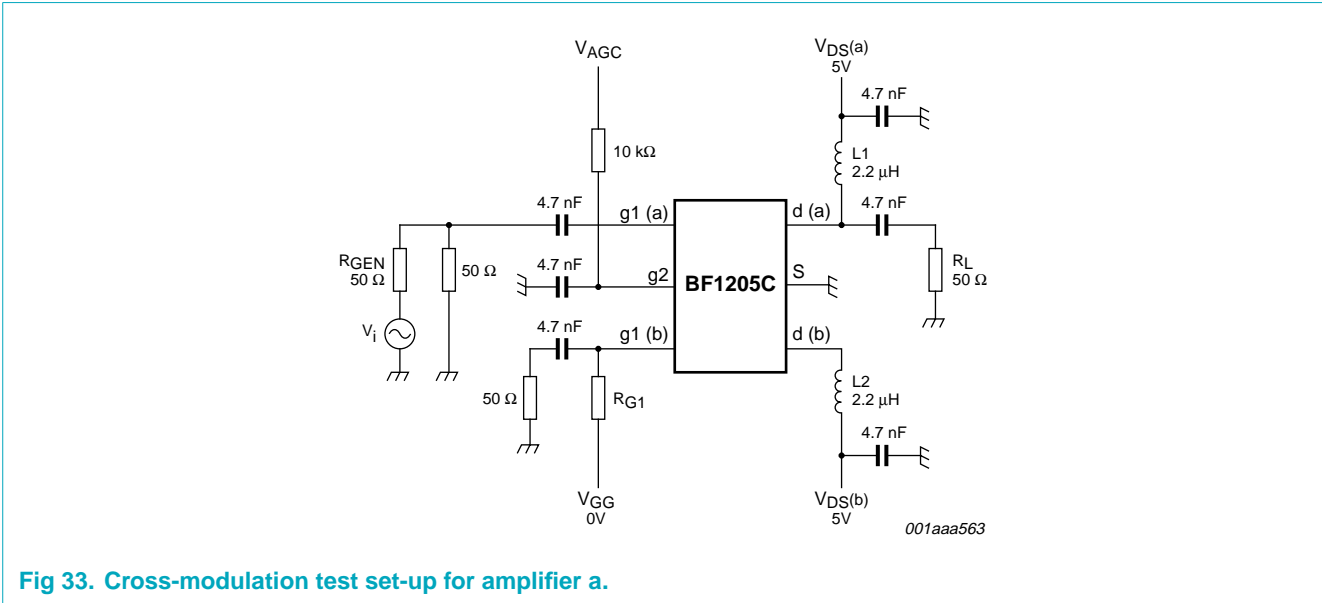

Fig 33. Cross-modulation test set-up for amplifier a.

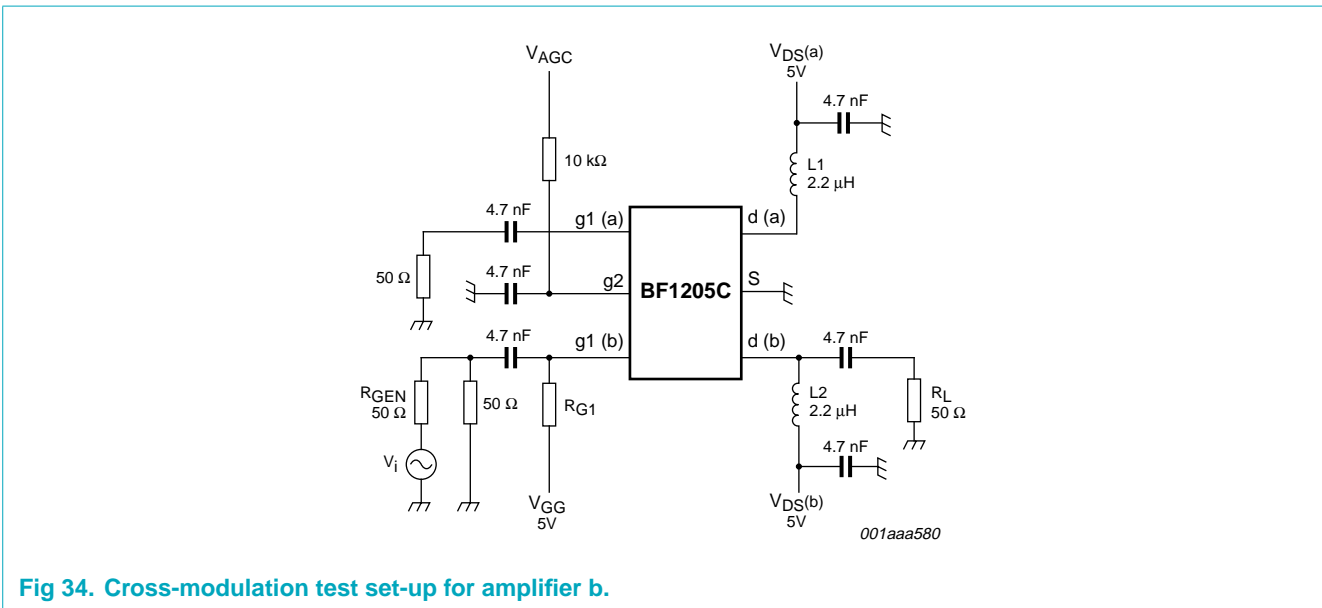

Fig 34. Cross-modulation test set-up for amplifier b.

10. Package outline

Plastic surface-mounted package; 6 leads

SOT363

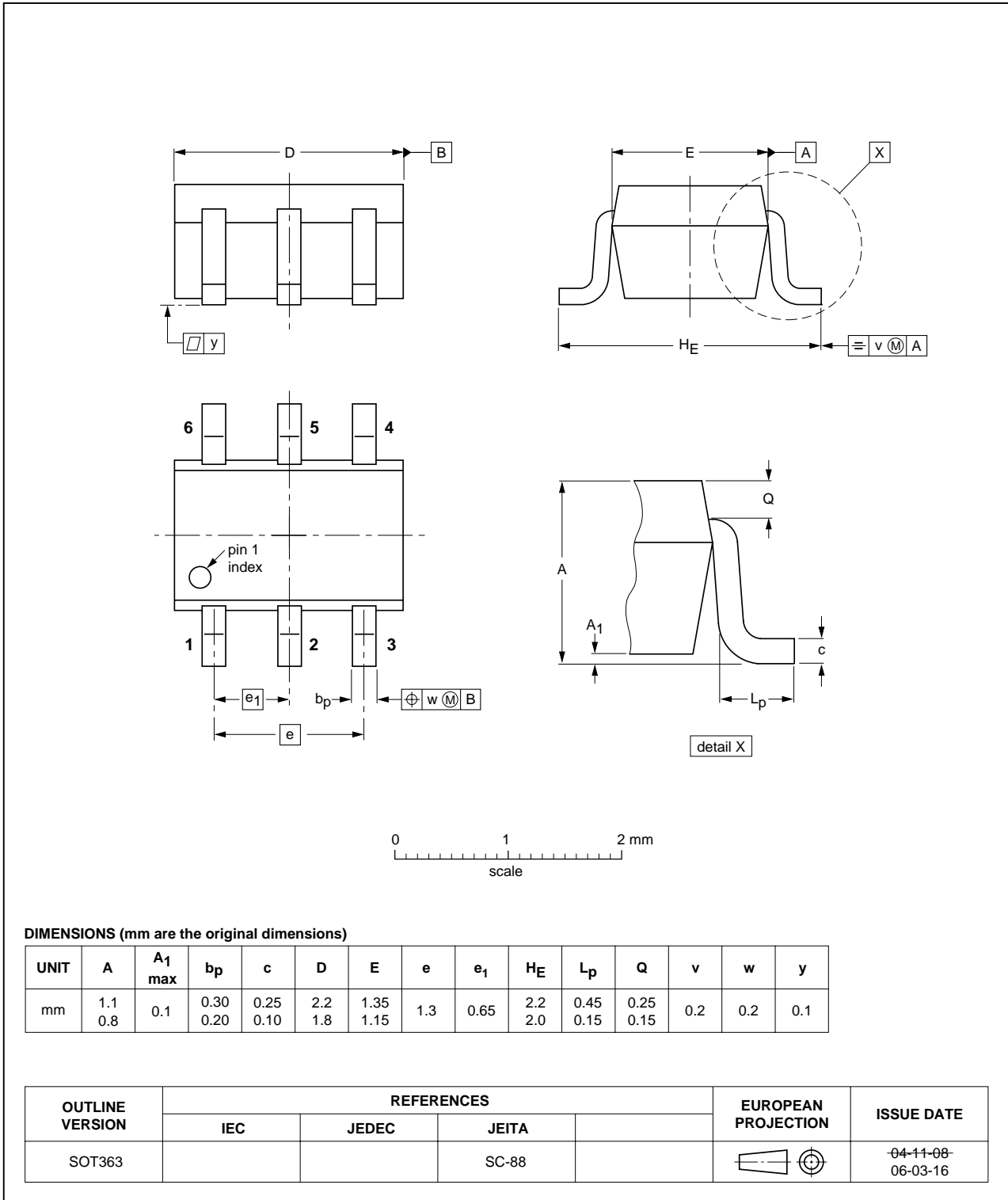

Fig 35. Package outline.

11. Revision history

Table 14. Revision history

Document ID	Release date	Data sheet status	Change notice	Supersedes
BF1205C_2	20060815	Product data sheet	-	BF1205C_1 (9397 750 13005)
Modifications:	• Figure 1 : replaced drawing with correct drawing 001aac193			
BF1205C_1 (9397 750 13005)	20040518	Product data sheet	-	-

12. Legal information

12.1 Data sheet status

Document status ^{[1][2]}	Product status ^[3]	Definition
Objective [short] data sheet	Development	This document contains data from the objective specification for product development.
Preliminary [short] data sheet	Qualification	This document contains data from the preliminary specification.
Product [short] data sheet	Production	This document contains the product specification.

[1] Please consult the most recently issued document before initiating or completing a design.

[2] The term 'short data sheet' is explained in section "Definitions".

[3] The product status of device(s) described in this document may have changed since this document was published and may differ in case of multiple devices. The latest product status information is available on the Internet at URL <http://www.semiconductors.philips.com>.

12.2 Definitions

Draft — The document is a draft version only. The content is still under internal review and subject to formal approval, which may result in modifications or additions. Philips Semiconductors does not give any representations or warranties as to the accuracy or completeness of information included herein and shall have no liability for the consequences of use of such information.

Short data sheet — A short data sheet is an extract from a full data sheet with the same product type number(s) and title. A short data sheet is intended for quick reference only and should not be relied upon to contain detailed and full information. For detailed and full information see the relevant full data sheet, which is available on request via the local Philips Semiconductors sales office. In case of any inconsistency or conflict with the short data sheet, the full data sheet shall prevail.

12.3 Disclaimers

General — Information in this document is believed to be accurate and reliable. However, Philips Semiconductors does not give any representations or warranties, expressed or implied, as to the accuracy or completeness of such information and shall have no liability for the consequences of use of such information.

Right to make changes — Philips Semiconductors reserves the right to make changes to information published in this document, including without limitation specifications and product descriptions, at any time and without notice. This document supersedes and replaces all information supplied prior to the publication hereof.

Suitability for use — Philips Semiconductors products are not designed, authorized or warranted to be suitable for use in medical, military, aircraft, space or life support equipment, nor in applications where failure or

malfunction of a Philips Semiconductors product can reasonably be expected to result in personal injury, death or severe property or environmental damage. Philips Semiconductors accepts no liability for inclusion and/or use of Philips Semiconductors products in such equipment or applications and therefore such inclusion and/or use is at the customer's own risk.

Applications — Applications that are described herein for any of these products are for illustrative purposes only. Philips Semiconductors makes no representation or warranty that such applications will be suitable for the specified use without further testing or modification.

Limiting values — Stress above one or more limiting values (as defined in the Absolute Maximum Ratings System of IEC 60134) may cause permanent damage to the device. Limiting values are stress ratings only and operation of the device at these or any other conditions above those given in the Characteristics sections of this document is not implied. Exposure to limiting values for extended periods may affect device reliability.

Terms and conditions of sale — Philips Semiconductors products are sold subject to the general terms and conditions of commercial sale, as published at <http://www.semiconductors.philips.com/profile/terms>, including those pertaining to warranty, intellectual property rights infringement and limitation of liability, unless explicitly otherwise agreed to in writing by Philips Semiconductors. In case of any inconsistency or conflict between information in this document and such terms and conditions, the latter will prevail.

No offer to sell or license — Nothing in this document may be interpreted or construed as an offer to sell products that is open for acceptance or the grant, conveyance or implication of any license under any copyrights, patents or other industrial or intellectual property rights.

12.4 Trademarks

Notice: All referenced brands, product names, service names and trademarks are the property of their respective owners.

13. Contact information

For additional information, please visit: <http://www.semiconductors.philips.com>

For sales office addresses, send an email to: sales.addresses@www.semiconductors.philips.com

14. Contents

1	Product profile	1
1.1	General description	1
1.2	Features	1
1.3	Applications	1
1.4	Quick reference data	2
2	Pinning information	2
3	Ordering information	3
4	Marking	3
5	Limiting values	3
6	Thermal characteristics	3
7	Static characteristics	4
8	Dynamic characteristics	5
8.1	Dynamic characteristics for amplifier a	5
8.1.1	Graphs for amplifier a	6
8.1.2	Scattering parameters for amplifier a	10
8.1.3	Noise data for amplifier a	10
8.2	Dynamic characteristics for amplifier b	11
8.2.1	Graphs for amplifier b	12
8.2.2	Scattering parameters for amplifier b	17
8.2.3	Noise data for amplifier b	17
9	Test information	18
10	Package outline	19
11	Revision history	20
12	Legal information	21
12.1	Data sheet status	21
12.2	Definitions	21
12.3	Disclaimers	21
12.4	Trademarks	21
13	Contact information	21
14	Contents	22

Please be aware that important notices concerning this document and the product(s) described herein, have been included in section 'Legal information'.



© Koninklijke Philips Electronics N.V. 2006. All rights reserved.

For more information, please visit: <http://www.semiconductors.philips.com>.

For sales office addresses, email to: sales.addresses@www.semiconductors.philips.com.

Date of release: 15 August 2006

Document identifier: BF1205C_2