



DC COMPONENTS CO., LTD.

DISCRETE SEMICONDUCTORS

MPSA42M

TECHNICAL SPECIFICATIONS OF NPN EPITAXIAL PLANAR TRANSISTOR

Description

Designed for use as a video output to drive color CRT, or as a dialer circuit in electronic telephone.

Pinning

- 1 = Emitter
- 2 = Base
- 3 = Collector

Absolute Maximum Ratings (T_A=25°C)

Characteristic	Symbol	Rating	Unit
Collector-Base Voltage	V _{CB0}	300	V
Collector-Emitter Voltage	V _{CE0}	300	V
Emitter-Base Voltage	V _{EB0}	6	V
Collector Current	I _C	800	mA
Total Power Dissipation	P _D	625	mW
Junction Temperature	T _J	+150	°C
Storage Temperature	T _{STG}	-55 to +150	°C

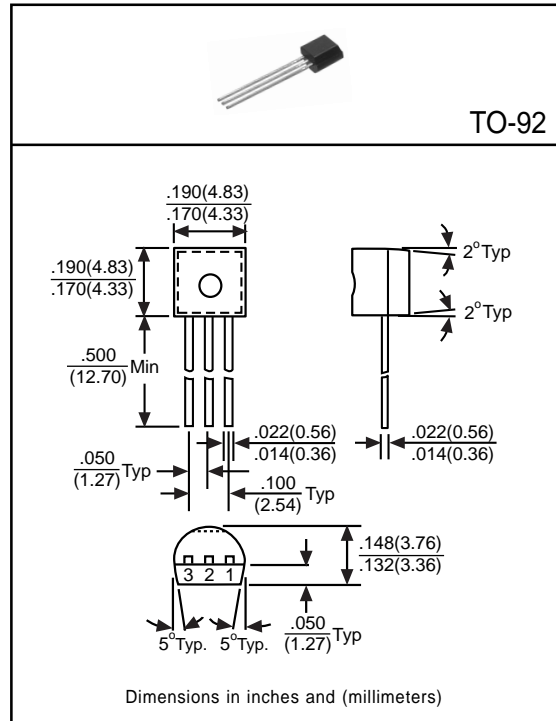

Electrical Characteristics

(Ratings at 25°C ambient temperature unless otherwise specified)

Characteristic	Symbol	Min	Typ	Max	Unit	Test Conditions
Collector-Base Breakdown Voltage	BV _{CB0}	300	-	-	V	I _C =100μA, I _E =0
Collector-Emitter Breakdown Voltage	BV _{CE0}	300	-	-	V	I _C =1mA, I _B =0
Emitter-Base Breakdown Voltage	BV _{EB0}	6	-	-	V	I _E =10μA, I _C =0
Emitter Cutoff Current	I _{EBO}	-	-	0.1	μA	V _{EB} =3V, I _C =0
Collector-Emitter Saturation Voltage ⁽¹⁾	V _{CE(sat)1}	-	-	0.2	V	I _C =20mA, I _B =2mA
	V _{CE(sat)2}	-	-	0.75	V	I _C =100mA, I _B =10mA
Base-Emitter Saturation Voltage ⁽¹⁾	V _{BE(sat)1}	-	-	0.9	V	I _C =20mA, I _B =2mA
	V _{BE(sat)2}	-	-	1	V	I _C =100mA, I _B =10mA
DC Current Gain ⁽¹⁾	h _{FE1}	80	-	-	-	I _C =10mA, V _{CE} =10V
	h _{FE2}	80	-	-	-	I _C =100mA, V _{CE} =10V
	h _{FE3}	40	-	-	-	I _C =200mA, V _{CE} =10V
Transition Frequency	f _T	50	-	-	MHz	I _C =10mA, V _{CE} =20V, f=100MHz

(1) Pulse Test: Pulse Width ≤ 380μs, Duty Cycle ≤ 2%