

FEATURES

- -55°C to +85°C operation
- 18 to 40 VDC input (19 to 40 VDC MTW2805S)
- Fully Isolated
- Optocoupler feedback
- Fixed frequency
- Topology – Push-Pull Forward
- 50 V for up to 50 ms transient protection
- Inhibit function
- Indefinite short circuit protection
- Remote sense on MTW2805S model
- Up to 86% efficiency

DC/DC CONVERTERS 28 VOLT INPUT



Size (max.): 2.720 x 1.350 x 0.505 inches (69.09 x 34.29 x 12.83 mm)
See Section B8, case J5, for dimensions.
Weight: 60 grams max.
Screening: Standard or ES. See Section C2 for screening options, see Section A5 for ordering information.

MTW SERIES 30 WATT

MODELS VDC OUTPUT

SINGLE	DUAL
5	±12
12	±15
15	

DESCRIPTION

The MTW Series™ of DC/DC converters offer the high efficiency and wide input voltage range of switching regulators with the isolation, excellent output regulation, and low output noise typical of linear regulators without requiring the use of external components. MTW converters are built using thick-film hybrid technology and are sealed in metal packages for military, aerospace and other high-reliability applications. Unscreened models are sealed with solder and are guaranteed to pass a gross leak test (maximum leak rate of 1×10^{-9} atm.-cc/sec). Environmentally screened models (ES) are hermetically sealed with solder and will pass a fine leak and gross leak test as described in Section C2.

MTW converters use a constant frequency pulse-width modulated switching regulator design operating in the forward mode with a clock switching frequency of 240 to 300 kHz. Isolation is achieved through the use of a transformer in the forward power circuit and an optocoupler in the feedback control loop. The full load output power of 30 watts is available over the entire 18 to 40 VDC (19 to 40 VDC for MTW2805S) input range. On dual output models, up to 90% of full power is available from either output up to a combined total of 30 watts. Input transients of 50 V to up to 50 ms. duration will not impair normal operation.

Efficiency is high over the entire input voltage range and from approximately 25% of full load to full load (see typical efficiency curves).

MTW converters are provided with indefinite short circuit protection through the use of current limiting techniques. When the output current reaches approximately 125% of the full rated load, the output voltage begins to reduce to protect the converter. The converter can sustain a true short circuit condition indefinitely.

With temperatures measured at the baseplate, the MTW Series is rated for full power operation from -55°C to +85°C with the power derated linearly to 0 at 115°C. The MTW's flanged case facilitates removal of heat and provides for mechanically secure mounting. In applications requiring full power operation, an efficient heat sink attached to the baseplate is required.

An inhibit is provided to allow power shut-down and start-up from a logic input. An open circuit on the inhibit pin allows normal operation, while a connection between the inhibit pin and input common disables the internal oscillator and shuts down the output. In the inhibit mode, approximately 1 mA must be sunk from pin the inhibit pin. An open collector, active low, is required to activate the inhibit function.

All MTW converters are characterized by close output regulation over the entire operating range with no minimum power requirement. On 12 and 15 VDC output models, typical line regulation is 10 to 20 mv. The MTW2805S model uses external remote sense pins which monitor the voltage at the load to provide typical regulation in the 5 to 7 mV range. The voltage sensing circuitry operates in a true four terminal voltage mode, eliminating the adverse effects of line resistance voltage drops. The remote sense pins may be left unconnected, but see cautions in on the following pages. For normal operation, remote sense pins should be connected to their respective output pins.

The MTW Series offers low noise on both the input and output line. In the single output converters, two-section L-C filters at both the input and output limit output ripple voltage and minimize reflected ripple on the input line. A small value (1000 pF, 500 V) ceramic capacitor connected between the case and input common pin of the single volt output models will reduce EMI on the input lines to levels near those required by MIL-STD-461C's CE03 standard. In the dual output converters, single-section L-C filters are used at the input and outputs. If compliance with MIL-STD-461 is necessary, use of Interpoint's FMA-416 EMI filter or FM-704A transient suppressor is recommended.

CRANE **interpoint**
A CRANE CO. COMPANY

B4-9

MTW SERIES 30 WATT

DC/DC CONVERTERS

ABSOLUTE MAXIMUM RATINGS	
Input Voltage	<ul style="list-style-type: none"> 18 to 40 VDC (19 to 40 VDC MTW2805S)
Output Power	<ul style="list-style-type: none"> 30 watts
Lead Soldering Temperature (10 sec per lead)	<ul style="list-style-type: none"> 300°C
Storage Temperature Range (Case)	<ul style="list-style-type: none"> -55°C to +125°C

INHIBIT	
Inhibit TTL Open Collector	<ul style="list-style-type: none"> Logic low (output disabled) Inhibit pin current 1 mA typical
	<ul style="list-style-type: none"> Referenced to input common Logic high (output enabled) Open collector

TYPICAL CHARACTERISTICS	
Output Voltage Temperature Coefficient	<ul style="list-style-type: none"> 100 ppm/°C, typical
Input to Output Capacitance	<ul style="list-style-type: none"> 80 pF typical single output models 70 pF typical MTW2812D 60 pF typical MTW2815D
Current Limit	<ul style="list-style-type: none"> 125% of full load typical
Isolation	<ul style="list-style-type: none"> 100 megohm minimum at 500 V
Conversion Frequency	<ul style="list-style-type: none"> 240 to 300 kHz
Inhibit Pin Voltage (unit enabled)	<ul style="list-style-type: none"> 11 to 15 V single output models 8 to 12 V MTW2812D 10 to 14 V MTW2815D

RECOMMENDED OPERATING CONDITIONS	
Input Voltage Range	<ul style="list-style-type: none"> 18 to 40 VDC continuous (19 to 40 MTW2805S) 50 V for 50 msec transient
Case Operating Temperature (Tc)	<ul style="list-style-type: none"> -55°C to +85°C full power -55°C to +115°C absolute
Derating Output Power/Current	<ul style="list-style-type: none"> Linearly from 100% at 85°C to 0% at 115° C

Electrical Characteristics: 25°C Tc, 28 VDC Vin, 100% load, unless otherwise specified.

PARAMETER	CONDITIONS	MTW2805S			MTW2812S			MTW2815S			UNITS
		MIN	TYP	MAX	MIN	TYP	MAX	MIN	TYP	MAX	
OUTPUT VOLTAGE		4.95	5.0	5.05	11.88	12.0	12.12	14.85	15.0	15.15	VDC
OUTPUT CURRENT		—	—	6.0	—	—	2.5	—	—	2.0	A
OUTPUT POWER	-55°C TO +85°C	—	—	30.0	—	—	30.0	—	—	30.0	W
OUTPUT RIPPLE	BW ≤ 2 MHz	—	30	50	—	30	65	—	30	65	mV p-p
LINE REGULATION ¹	MIN. TO MAX. V _{IN}	—	7	20	—	10	25	—	10	25	mV
LOAD REGULATION ¹	NO LOAD TO FULL	—	5	20	—	10	20	—	10	20	mV
INPUT VOLTAGE	NO LOAD TO FULL	19	28	40	18	28	40	18	28	40	VDC
	-55°C TO +85°C TRANSIENT 50 ms	—	—	50	—	—	50	—	—	50	
INPUT CURRENT	NO LOAD	—	15	20	—	20	35	—	20	35	mA
	FULL LOAD	—	—	1370	—	—	1400	—	—	1400	
	INHIBITED	—	—	15	—	—	22	—	—	22	
INPUT RIPPLE CURRENT	BW ≤ 2 MHz	—	5	10	—	10	20	—	10	20	mA p-p
EFFICIENCY		80	82	—	82	84	—	84	86	—	%
START-UP	DELAY ²	—	15	—	—	30	—	—	40	—	ms
	OVERSHOOT	—	300	—	—	400	—	—	400	—	mV

Notes

- For MTW2805S, with the remote sense pins connected to the load and no resistance between the output pins and load.
- A low output impedance power source is required on the input to realize this start-up time. If less than full surge current is available, start-up time will be longer

CAUTION

Permanent damage to the MTW2805S will result if pin 6 is shorted to ground. Damage may also result if pin 4 or pin 5 is disconnected from the load during operation with the remote sense leads connected to the load. If remote sense pins are not connected to the load, the output voltage of the MTW2805S will rise to approximately 6.2 VDC measured across pins 4 and 5.

DC/DC CONVERTERS

MTW SERIES 30 WATT

Electrical Characteristics: 25°C Tc, 28 VDC Vin, 100% load, unless otherwise specified.

PARAMETER	CONDITION	MTW2812D			MTW2815D			UNITS
		MIN	TYP	MAX	MIN	TYP	MAX	
OUTPUT VOLTAGE	+V _{OUT}	11.88	12.0	12.12	14.85	15.0	15.15	VDC
	-V _{OUT}	11.88	12.0	12.12	14.85	15.0	15.15	
OUTPUT CURRENT		—	—	2.5	—	—	2.0	A
OUTPUT POWER ¹	-55°C to +85°C	—	—	30.0	—	—	30.0	W
OUTPUT RIPPLE VOLTAGE	BW ≤ 2 MHz	—	50	85	—	50	85	mV p-p
LINE REGULATION	V _{IN} = 18 TO 40	—	10	25	—	10	25	mV
LOAD REGULATION	NO LOAD TO FULL	—	20	50	—	20	50	mV
CROSS REGULATION ²	+V _{OUT}	—	2.5	3.5	—	2.2	3.2	%
	-V _{OUT}	—	2.5	3.5	—	2.2	3.2	
INPUT VOLTAGE	CONTINUOUS	18	28	40	18	28	40	VDC
	-55°C to +85°C TRANSIENT 50 ms	—	—	50	—	—	50	
INPUT CURRENT	NO LOAD	—	35	50	—	45	60	mA
	FULL LOAD	—	—	1350	—	—	1400	
	INHIBITED	—	—	24	—	—	24	
INPUT RIPPLE CURRENT	BW ≤ 2 MHz	—	15	50	—	15	50	mA p-p
EFFICIENCY		81	84	—	82	85	—	%
START-UP	DELAY ³	—	30	—	—	30	—	ms
	OVERSHOOT	—	500	—	—	500	—	mV

Notes

- Up to 90% of full power is available from either output providing the total power does not exceed 30 watts.
- The effect on the output voltage of either output (held at 3 watts) when the other output is varied from 3 to 27 watts.
- A low output impedance power source is required on the input to realize this start-up time. If less than full surge current is available, start-up time will be longer

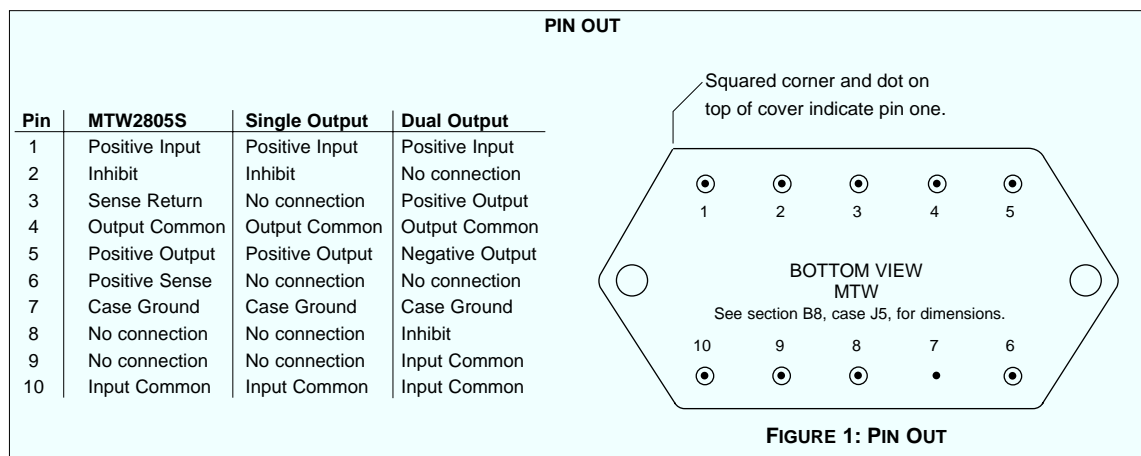

CRANE

interpoint

A CRANE CO. COMPANY

B4-11

MTW SERIES 30 WATT

DC/DC CONVERTERS

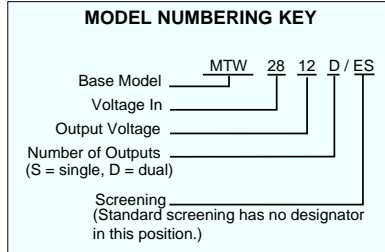

Typical Performance Curves: 25°C Tc

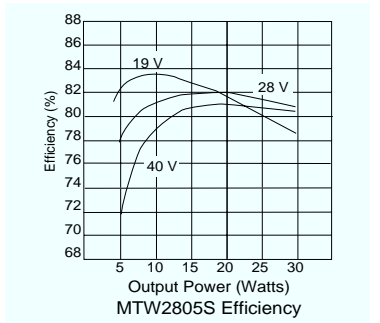

FIGURE 2

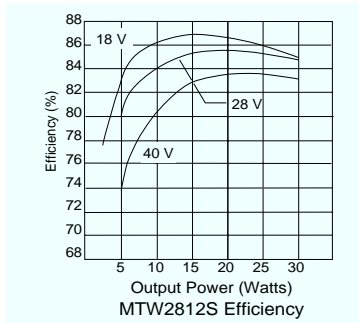

FIGURE 3

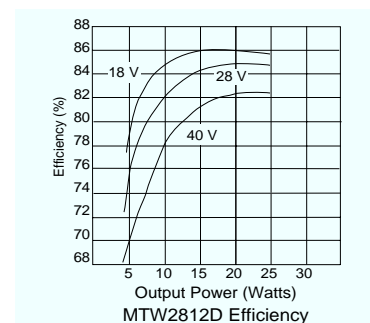

FIGURE 4

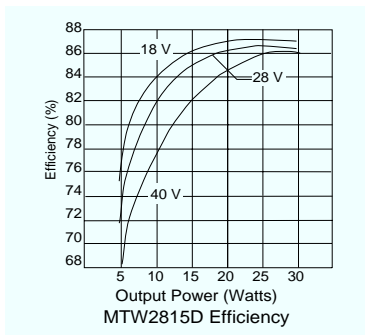

FIGURE 5

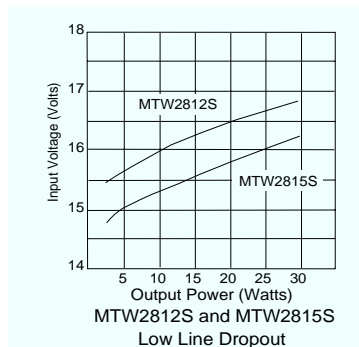

FIGURE 6

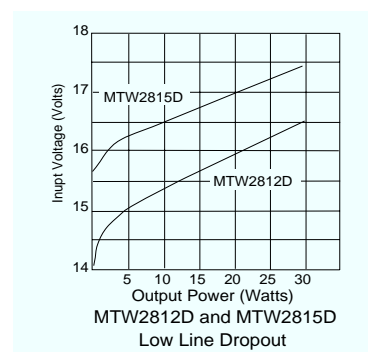
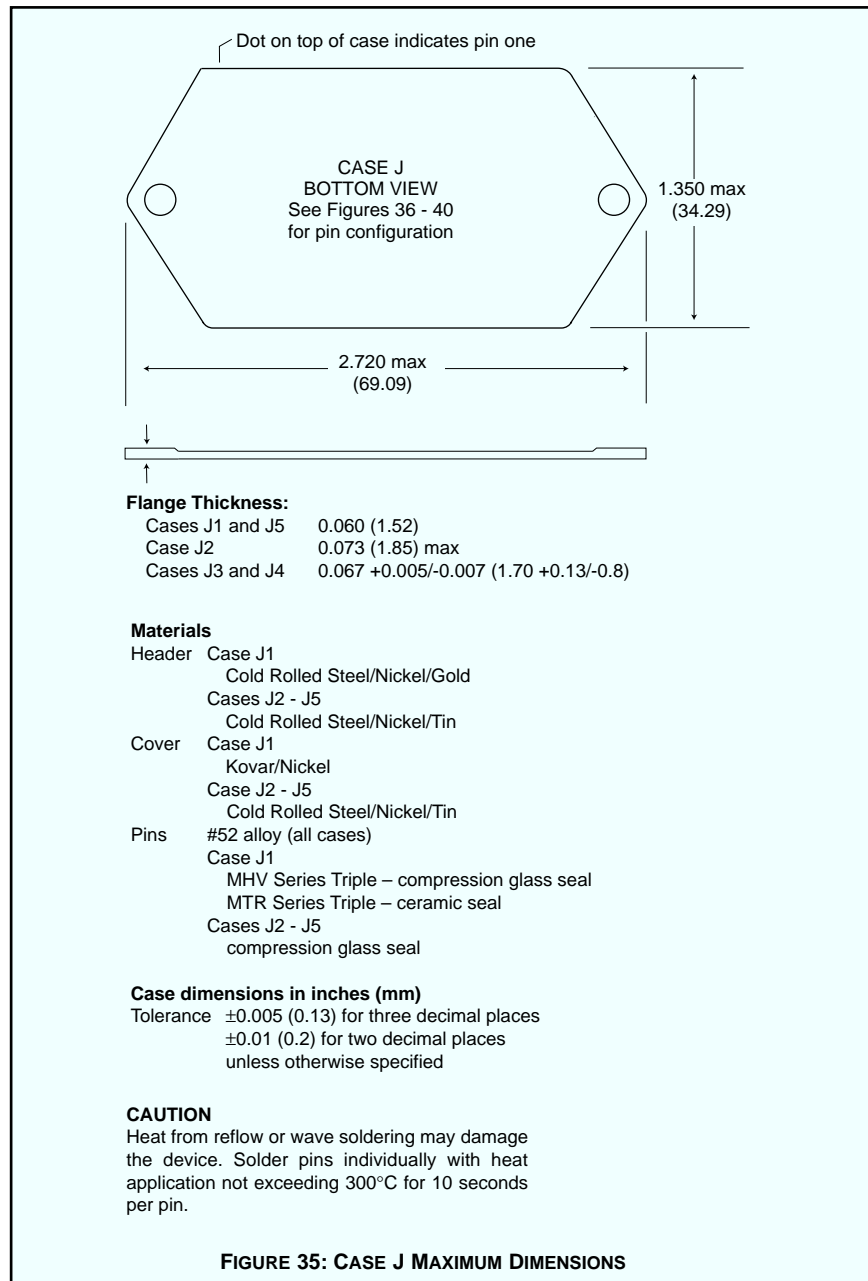

FIGURE 7

B4-12

24421-001-DTS Rev A DQ# 1017
All technical information is believed to be accurate, but no responsibility is assumed for errors or omissions. Interpoint reserves the right to make changes in products or specifications without notice. MTW Series is a trademark of Interpoint. Copyright © 1994 - 1999 Interpoint. All rights reserved.





Note: Although every effort has been made to render the case drawings at actual size, variations in the printing process may cause some distortion. Please refer to the numerical dimensions for accuracy.

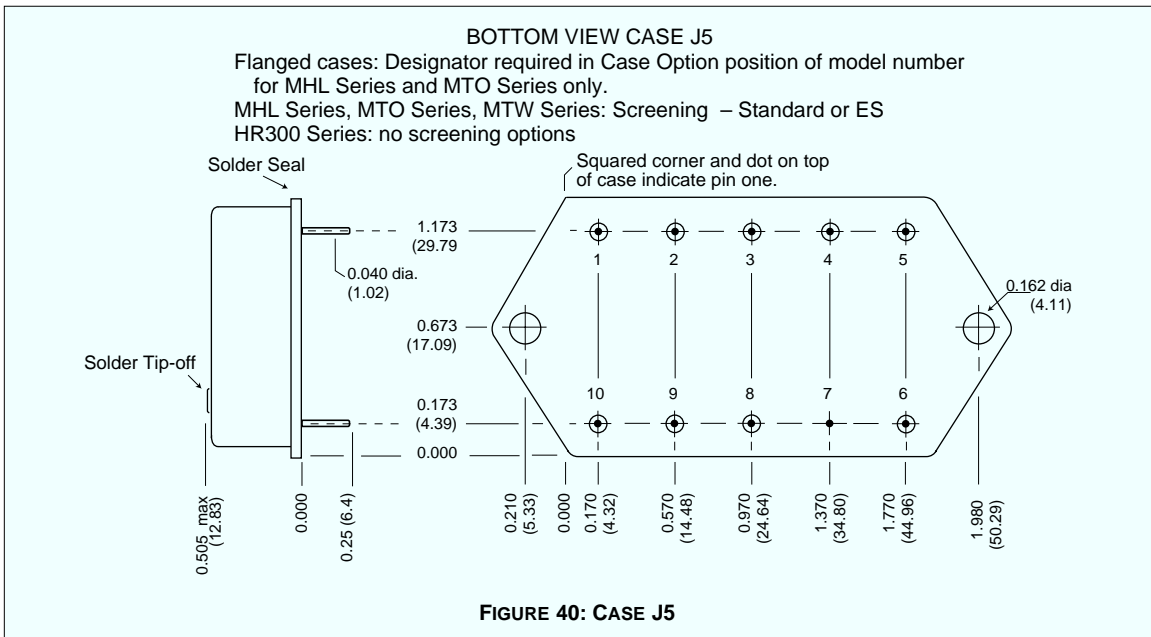
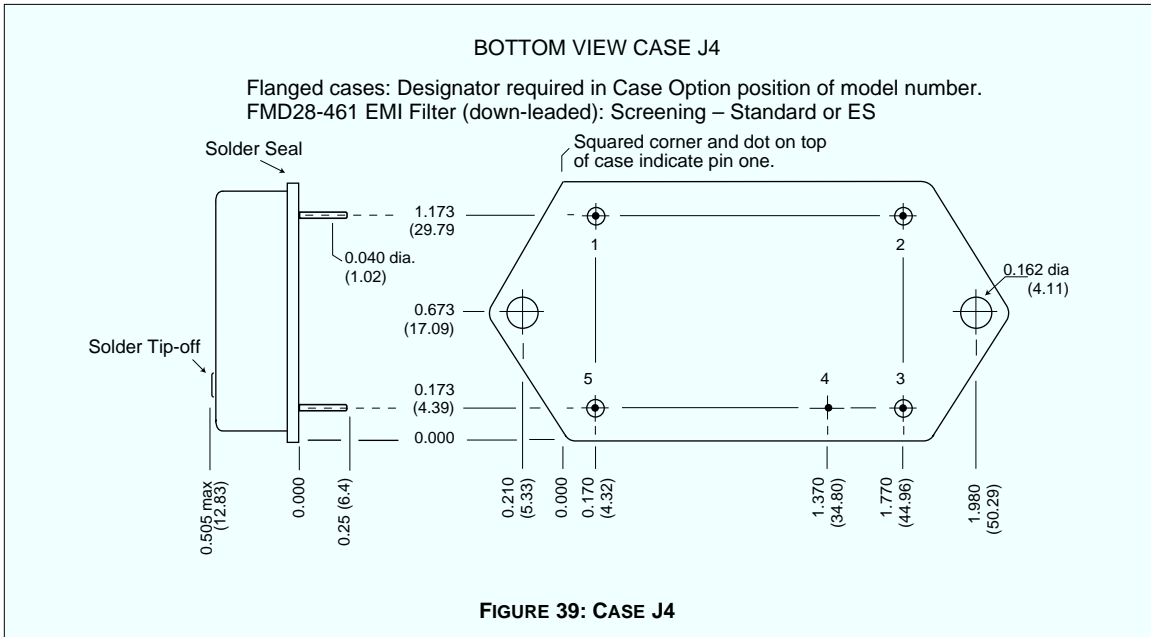

QA SCREENING 85°C PRODUCTS

85°C PRODUCTS

TEST (85°C Products excluding HR products)	STANDARD	/ES
PRE-CAP INSPECTION Method 2017	yes	yes
TEMPERATURE CYCLE (10 times) Method 1010, Cond. B, -55°C to 125°C	no	yes
CONSTANT ACCELERATION Method 2001, 500 g	no	yes
BURN-IN 96 hours at 70°C ambient (typical)	no	yes
FINAL ELECTRICAL TEST MIL-PRF-38534, Group A Subgroups 1 and 4: +25°C case	yes	yes
HERMETICITY TESTING Fine Leak, Method 1014, Cond. A Gross Leak, Method 1014, Cond. C Gross Leak, Dip (1 x 10 ⁻³)	no no yes	yes yes no
FINAL VISUAL INSPECTION Method 2009	yes	yes

Test methods are referenced to MIL-STD-883 as determined by MIL-PRF-38534.

Applies to the following products:

MFW Series
MTW Series
MHE/MLP Series
MHL Series
MRH Series
MTO Series
MSR Series
DCH Series
FM/FMA/FMB EMI Filters
MSF EMI Filter