



Micro Commercial Components

Micro Commercial Components
20736 Marilla Street Chatsworth
CA 91311
Phone: (818) 701-4933
Fax: (818) 701-4939

DTC144TE

Features

- Built-in bias resistors enable the configuration of an inverter circuit without connecting external input resistors (see equivalent circuit)
- The bias resistors consist of thin-film resistors with complete isolation to allow negative biasing of the input. They also have the advantage of almost completely eliminating parasitic effects
- Only the on/off conditions need to be set for operation, making device design easy

Absolute Maximum Ratings

Parameter	Symbol	Value	Unit
Collector-Base Voltage	V_{CBO}	50	V
Collector-Emitter Voltage	V_{CEO}	50	V
Emitter-Base voltage	V_{EBO}	5	V
Collector Current-Continuous	I_C	100	mA
Collector Dissipation	P_C	150	mW
Junction Temperature	T_J	150	°C
Storage Temperature Range	T_{STG}	-55~150	°C

- Case Material: Molded Plastic. UL Flammability Classification Rating 94V-0 and MSL Rating 1

Electrical Characteristics

Sym	Parameter	Min	Typ	Max	Unit
$V_{(BR)CBO}$	Collector-Base Breakdown Voltage ($I_C=50\mu A, I_E=0$)	50	---	---	V
$V_{(BR)CEO}$	Collector-Emitter Breakdown Voltage ($I_C=1mA, I_B=0$)	50	---	---	V
$V_{(BR)EBO}$	Emitter-Base Breakdown Voltage ($I_E=50\mu A, I_C=0$)	5	---	---	V
I_{CBO}	Collector Cut-off Current ($V_{CB}=50V, I_E=0$)	---	---	0.5	μA
I_{EBO}	Emitter Cut-off Current ($V_{EB}=4V, I_C=0$)	---	---	0.5	μA
h_{FE}	DC Current Gain ($V_{CE}=5V, I_C=1mA$)	100	300	600	---
$V_{CE(sat)}$	Collector-Emitter Saturation Voltage ($I_C=10mA, I_B=1mA$)	---	---	0.3	V
R_1	Input resistance	32.9	47	61.1	K Ω
f_T	Transition Frequency ($V_{CE}=10V, I_C=-5mA, f=100MHz$)	---	250	---	MHz

NPN Digital Transistor

SOT-523

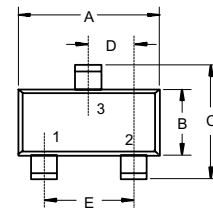

1. Base
2. Emitter
3. Collector

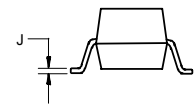
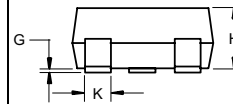

DIM	DIMENSIONS				NOTE
	INCHES		MM		
	MIN	MAX	MIN	MAX	
A	.059	.067	1.50	1.70	
B	.030	.033	0.75	0.85	
C	.057	.069	1.45	1.75	
D	.020 Nominal		0.50Nominal		
E	.035	.043	0.90	1.10	
G	.000	.004	.000	.100	
H	.028	.031	.70	0.80	
J	.004	.008	.100	.200	
K	.010	.014	.25	.35	

DTC144TE

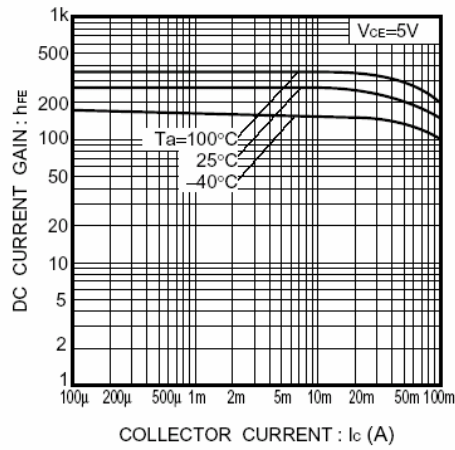

Fig.1 DC current gain vs. collector current

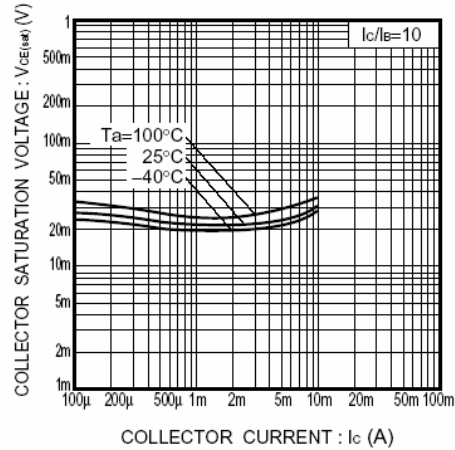
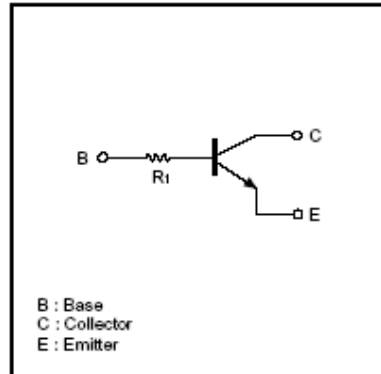

Fig.2 Collector-emitter saturation voltage vs. collector current

● Equivalent circuit





Micro Commercial Components

Ordering Information

Device	Packing
(Part Number)-TP	Tape&Reel;3Kpcs/Reel

IMPORTANT NOTICE

Micro Commercial Components Corp .reserves the right to make changes without further notice to any product herein to make corrections, modifications , enhancements , improvements , or other changes .
Micro Commercial Components Corp .does not assume any liability arising out of the application or use of any product described herein; neither does it convey any license under its patent rights ,nor the rights of others . The user of products in such applications shall assume all risks of such use and will agree to hold *Micro Commercial Components Corp* .and all the companies whose products are represented on our website, harmless against all damages.

APPLICATIONS DISCLAIMER

Products offer by *Micro Commercial Components Corp* . are not intended for use in Medical, Aerospace or Military Applications.

www.mccsemi.com