

DATA SHEET

UMA1015M

Low-power dual frequency
synthesizer for radio
communications

Product specification
Supersedes data of October 1994
File under Integrated Circuits, IC03

1995 Jun 22

Low-power dual frequency synthesizer for radio communications

UMA1015M

FEATURES

- Two fully programmable RF dividers up to 1.1 GHz
- Fully programmable reference divider up to 35 MHz
- 2 : 1 or 1 : 1 ratio of selectable reference frequencies
- Fast three-line serial bus interface
- Adjustable phase comparator gain
- Programmable out-of-lock indication for both loops
- On-chip voltage doubler
- Low current consumption from 3 V supply
- Separate power-down mode for each synthesizer
- Up to 4 open-drain output ports.

APPLICATIONS

- Cordless telephone
- Hand-held mobile radio.

GENERAL DESCRIPTION

The UMA1015M is a low-power dual frequency synthesizer for radio communications which operates in the 50 to 1100 MHz frequency range. Each synthesizer consists of a fully programmable main divider, a phase and frequency detector and a charge pump. There is a fully programmable reference divider common to both synthesizers which operates up to 35 MHz. The device is programmed via a 3-wire serial bus which operates up to 10 MHz. The charge pump currents (gains) are fixed by an external resistance at pin 20 (I_{SET}). The BiCMOS device is designed to operate from 2.6 V (3 Ni-Cd cells) to 5.5 V at low current. Digital supplies V_{DD1} and V_{DD2} must be at the same potential. The charge pump supply (V_{CC}) can be provided by an external source or on-chip voltage doubler. V_{CC} must be equal to or higher than V_{DD1} . Each synthesizer can be powered-down independently via the serial bus to save current. It is also possible to power-down the device via the HPD input (pin 5).

QUICK REFERENCE DATA

SYMBOL	PARAMETER	CONDITIONS	MIN.	TYP.	MAX.	UNIT
V_{DD1}, V_{DD2}	digital supply voltage	$V_{DD1} = V_{DD2}$	2.6	–	5.5	V
V_{CC}	charge pump supply voltage	external supply; doubler disabled; $V_{CC} \geq V_{DD}$	2.6	–	6.0	V
V_{CCvd}	charge pump supply from voltage doubler	doubler enabled	–	$2V_{DD1} - 0.6$	6.0	V
$I_{DDO1} + I_{DDO2} + I_{CCO}$	operating supply current	both synthesizers ON; doubler disabled; $V_{DD1} = V_{DD2} = 5.5$ V	–	9.6	–	mA
$I_{DD1pd} + I_{DD2pd} + I_{CCpd}$	current in power-down mode per supply	doubler disabled; $V_{DD1} = V_{DD2} = 5.5$ V	–	0.01	–	mA
I_{DD1pd}	current in power-down mode from supply V_{DD}	doubler enabled; $V_{DD1} = V_{DD2} = 3$ V	–	0.15	–	mA
f_{RFA}, f_{RFB}	RF input frequency for each synthesizer		50	–	1100	MHz
f_{XTALIN}	crystal input frequency		3	–	35	MHz
$f_{pc(min)}$	minimum phase comparator frequency	$f_{RF} = 50$ to 1100 MHz; $f_{XTALIN} = 3$ to 35 MHz	–	10	–	kHz
$f_{pc(max)}$	maximum phase comparator frequency	$f_{RF} = 50$ to 1100 MHz; $f_{XTALIN} = 3$ to 35 MHz	–	750	–	kHz
T_{amb}	operating ambient temperature	synthesizer A 2.6 V $\leq V_{DD} \leq 5.5$ V	–30	–	+85	°C
		synthesizer B 2.6 V $\leq V_{DD} \leq 4.5$ V	–30	–	+85	°C
		synthesizer B 2.6 V $\leq V_{DD} \leq 5.0$ V	0	–	+85	°C

Low-power dual frequency synthesizer for radio communications

UMA1015M

ORDERING INFORMATION

TYPE NUMBER	PACKAGE			
	PINS	PIN POSITION	MATERIAL	CODE
UMA1015M/C2	20	SSOP20	plastic	SOT266-1

BLOCK DIAGRAM

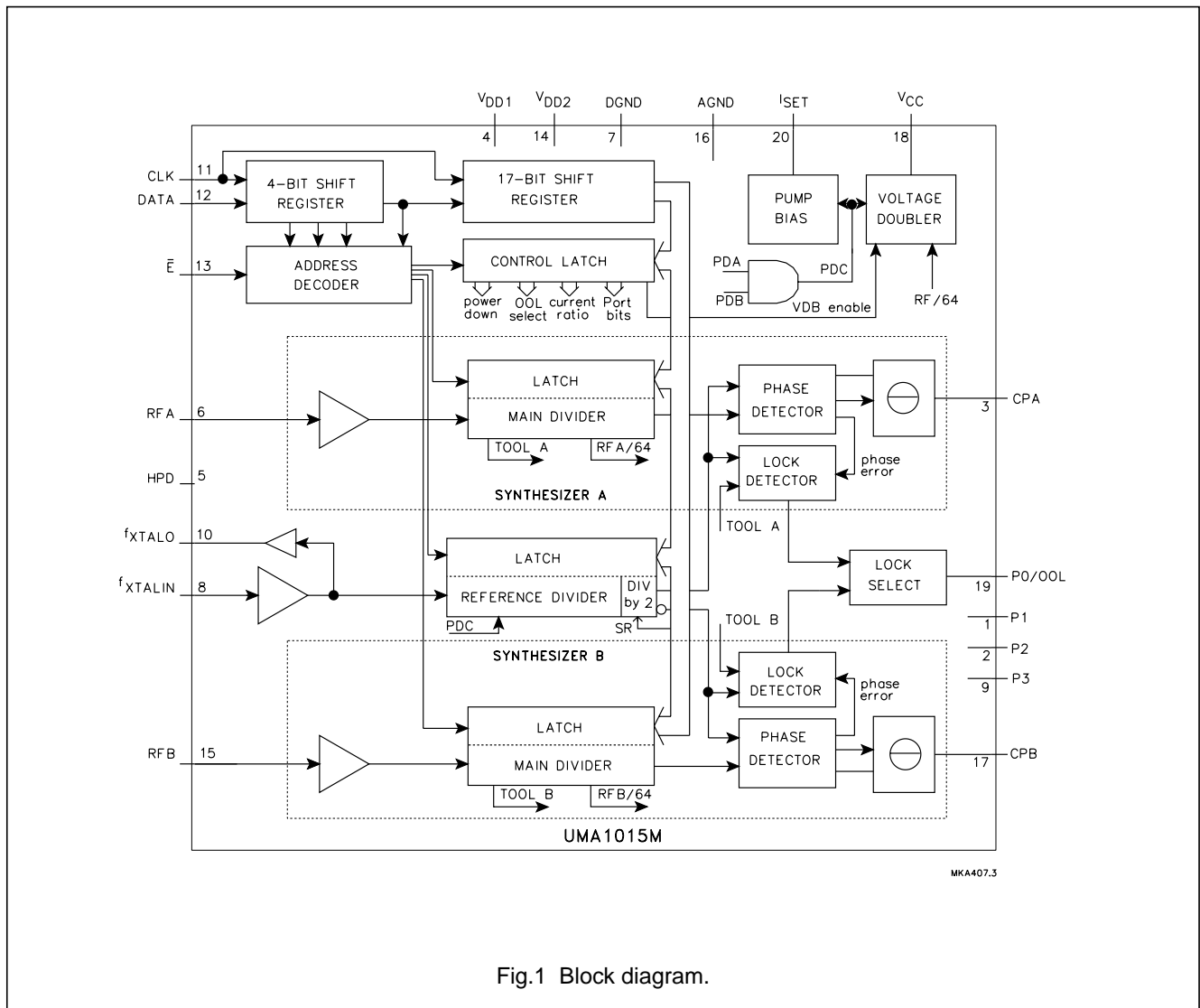

Low-power dual frequency synthesizer for radio communications

UMA1015M

PINNING

SYMBOL	PIN	DESCRIPTION
P1	1	output Port 1
P2	2	output Port 2
CPA	3	charge-pump output synthesizer A
V _{DD1}	4	digital supply voltage 1
HPD	5	hardware power-down (input LOW = power-down)
RFA	6	RF input synthesizer A
DGND	7	digital ground
f _{XTALIN}	8	common crystal frequency input from TCXO
P3	9	output Port 3
f _{XTALO}	10	open-drain output of f _{XTAL} signal
CLK	11	programming bus clock input
DATA	12	programming bus data input
\bar{E}	13	programming bus enable input (active LOW)
V _{DD2}	14	digital supply voltage 2
RFB	15	RF input synthesizer B
AGND	16	analog ground to charge pumps
CPB	17	charge pump output synthesizer B
V _{CC}	18	analog supply to charge pump; external or voltage doubler output
P0/OOL	19	Port output 0/out-of-lock output
I _{SET}	20	regulator pin to set charge-pump currents

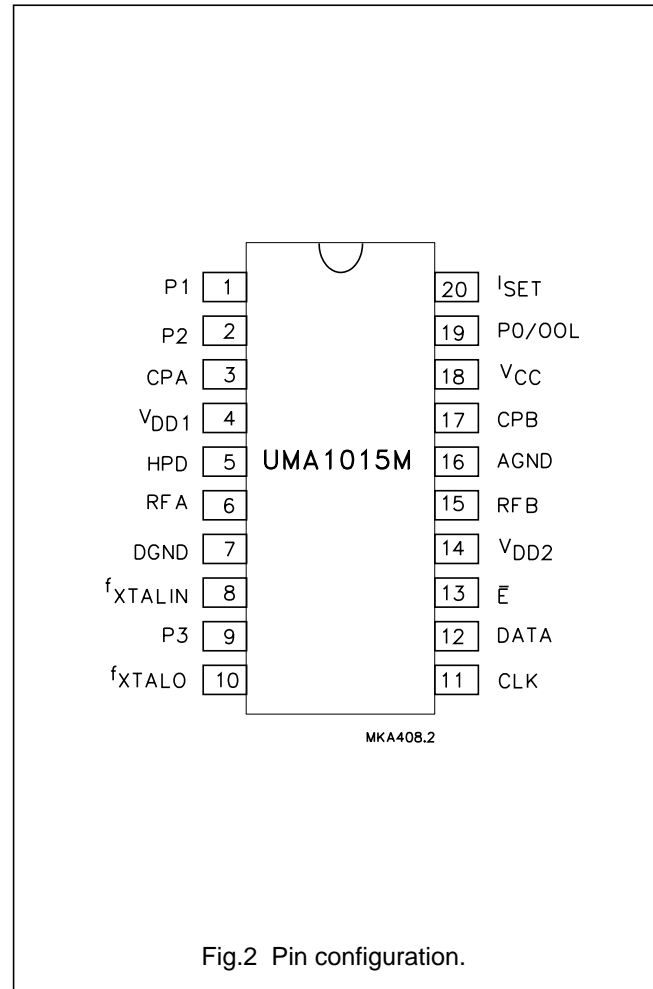

Fig.2 Pin configuration.

FUNCTIONAL DESCRIPTION

Main dividers

Each synthesizer has a fully programmable 17-bit main divider. The RF input drives a pre-amplifier to provide the clock to the first divider bit. The pre-amplifier has a high input impedance, dominated by pin and pad capacitance. The circuit operates with signal levels from below 50 mV (RMS) up to 250 mV (RMS), and at frequencies up to 1.1 GHz. The high frequency sections of the divider are implemented using bipolar transistors, while the slower section uses CMOS technology. The range of division ratios is 512 to 131071.

Reference divider

There is a common fully programmable 12-bit reference divider for the two synthesizers. The input f_{XTALIN} drives a

pre-amplifier to provide the clock input for the reference divider. This clock signal is also buffered and output on pin f_{XTALO} (open drain). An extra divide-by-2 block allows a reference comparison frequency for synthesizer B to be half that of synthesizer A. This feature is selectable using the program bit SR. If the programmed reference divider ratio is R then the ratio for each synthesizer is as given in Table 1.

The range for the division ratio R is 8 to 4095. Opposite edges of the divider output are used to drive the phase detectors to ensure that active edges arrive at the phase detectors of each synthesizer at different times. This minimizes the potential for interference between the charge pumps of each loop. The reference divider consists of CMOS devices operating beyond 35 MHz.

Low-power dual frequency synthesizer for radio communications

UMA1015M

Table 1 Synthesizer ratio of reference divider

SR	SYNTHESIZER A	SYNTHESIZER B
0	R	R
1	R	2R

Phase comparators

For each synthesizer, the outputs of the main and reference dividers drive a phase comparator where a charge pump produces phase error current pulses for integration in an external loop filter. The charge pump current is set by an external resistance R_{SET} at pin I_{SET} , where a temperature-independent voltage of 1.2 V is generated. R_{SET} should be between 12 k Ω and 60 k Ω (to give an I_{SET} of 100 μ A and 20 μ A respectively). The charge-pump current, I_{CP} , can be programmed to be either ($12 \times I_{SET}$) or ($24 \times I_{SET}$) with the maximum being 2.4 mA. The dead zone, caused by finite switching of current pulses, is cancelled by an internal delay in the phase detector thus giving improved linearity. The charge pump has a separate supply, V_{CC} , which helps to reduce the interference on the charge pump output from other parts of the circuit. Also, V_{CC} can be higher than V_{DD1} if a wider range on the VCO input is required. V_{CC} must not be less than V_{DD1} .

Voltage doubler

If required, there is a voltage doubler on-chip to supply the charge pumps at a higher level than the nominal available supply. The doubler operates from the digital supply V_{DD1} , and is internally limited to a maximum output of 6 V. An external capacitor is required on pin V_{CC} for smoothing, the capacitor required to develop the extra voltage is integrated on-chip. To minimize the noise being introduced to the charge pump output from the voltage doubler, the doubler clock is suppressed (provided both loops are in-lock) for the short time that the charge pumps are active. The doubler clock (RF/64) is derived from whichever main divider is operating (synthesizer A has priority). While both synthesizers are powered down (and the doubler is enabled), the doubler clock is supplied by a low-current internal oscillator. The doubler can be disabled by programming the bit VDON to logic 0, in order to allow an external charge pump supply to be used.

Out-of-lock indication/output ports

There is a lock detector on-chip for each synthesizer. The lock condition of each, or both loops, is output via an open-drain transistor which drives the pin P0/OOL (when out-of-lock, the transistor is turned on and therefore the

output is forced LOW). The lock condition output is software selectable (see Table 4). An out-of-lock condition is flagged when the phase error is greater than T_{OOL} , the value of which is approximately equal to 80 cycles of the relevant RF input. The out-of-lock flag is only released after 8 consecutive reference cycles where the phase error is less than T_{OOL} . The out-of-lock function can be disabled, via the serial bus, and the pin P0/OOL can be used as an output port. Three other port outputs P1, P2 and P3 (open-drain transistors) are also available.

Serial programming bus

A simple 3-line unidirectional serial bus is used to program the circuit. The 3 lines are DATA, CLK and \bar{E} (enable). The data sent to the device is loaded in bursts framed by \bar{E} . Programming clock edges are ignored until \bar{E} goes active LOW. The programmed information is loaded into the addressed latch when \bar{E} returns inactive HIGH. This is allowed when CLK is in either state without causing any consequences to the register data. Only the last 21 bits serially clocked into the device are retained within the programming register. Additional leading bits are ignored, and no check is made on the number of clock pulses. The fully static CMOS design uses virtually no current when the bus is inactive. It can always capture new programming data even during power-down of both synthesizers.

However when either synthesizer A or synthesizer B or both are powered-on, the presence of a TCXO signal is required at pin 8 (f_{XTALIN}) for correct programming.

Data format

Data is entered with the most significant bit first. The leading bits make up the data field, while the trailing four bits are an address field. The address bits are decoded on the rising edge of \bar{E} . This produces an internal load pulse to store the data in the addressed latch. To ensure that data is correctly loaded on first power-up, \bar{E} should be held LOW and only taken HIGH after having programmed an appropriate register. To avoid erroneous divider ratios, the pulse is inhibited during the period when data is read by the frequency dividers. This condition is guaranteed by respecting a minimum \bar{E} pulse width after data transfer. The data format and register bit allocations are shown in Table 2.

Low-power dual frequency synthesizer
for radio communications

UMA1015M

Table 2 Bit allocation

FIRST	REGISTER BIT ALLOCATION																				LAST
p1	p2	p3	p4	p5	p6	p7	p8	p9	p10	p11	p12	p13	p14	p15	p16	p17	p18	p19	p20	p21	
dt16	dt15	dt14	dt13	dt12	DATA FIELD							dt4	dt3	dt2	dt1	dt0	ADDRESS				
X	X	VDON	PO	OLA	OLB	CRA	CRB	X	X	sPDA	sPDB	P3	P2	P1	X	X	0	0	0	1	
MA16	SYNTHESIZER A MAIN DIVIDER COEFFICIENT															MA0	0	1	0	0	
0	0	0	0	SR	R11	REFERENCE DIVIDER COEFFICIENT										R0	0	1	0	1	
MB16	SYNTHESIZER B MAIN DIVIDER COEFFICIENT															MB0	0	1	1	0	
RESERVED FOR TEST ⁽¹⁾																	0	0	0	0	

Note

- The test register should not be programmed with any other values except all zeros for normal operation.

Table 3 Bit allocation description

SYMBOL	DESCRIPTION
sPDA, sPDB	software power-down for synthesizers A and B (0 = power-down)
P3, P2, P1 and P0	bits output to pins 1, 2, 9 and 19 (1 = high impedance)
VDON	voltage doubler enable (1 = doubler enabled)
OLA, OLB	out-of-lock select; selects signal output to pin 19 (see Table 4)
CRA, CRB	charge pump A/B current to I _{SET} ratio select (see Table 5)
SR	reference frequency ratio select (see Table 6)

Table 4 Out-of-lock select

OLA	OLB	OUTPUT AT PIN 19
0	0	P0
0	1	lock status of loop B; OOLB
1	0	lock status of loop A; OOLA
1	1	logic OR function of loops A and B

Table 5 Charge pump current ratio

CRA/CRB	CURRENT AT PUMP
0	I _{CP} = 12 × I _{SET}
1	I _{CP} = 24 × I _{SET}

Table 6 Reference division ratio

SR	SYNTHESIZER A	SYNTHESIZER B
0	R	R
1	R	2R

Low-power dual frequency synthesizer for radio communications

UMA1015M

Power-down modes

The device can be powered down either via pin HPD (active LOW = power-down) or via the serial bus (bits SPDA and SPDB, logic 0 = power-down). The synthesizers are powered up when both hardware and software Power-down signals are at logic 1. When only one synthesizer is powered down, the functions common to both will be maintained. When both synthesizers are

switched off, only the voltage doubler (if enabled) will remain active drawing a reduced current. An internal oscillator will drive the doubler in this situation. If both synthesizers have been in a power-down condition, then when one or both synthesizers are reactivated, the reference and main dividers restart in such a way as to avoid large random phase errors at the phase comparator.

LIMITING VALUES

In accordance with the Absolute Maximum Rating System (IEC 134).

SYMBOL	PARAMETER	MIN.	MAX.	UNIT
V_{DD1}, V_{DD2}	DC range of digital power supply voltage with respect to DGND	-0.3	+6.0	V
V_{CC}	DC charge pump supply voltage with respect to AGND	-0.3	+6.0	V
ΔV_{CC-DD}	difference in voltage between V_{CC} and V_{DD1}, V_{DD2}	-0.3	+6.0	V
V_n	DC voltage at pins 1, 2, 5, 6, 8 to 15, 19 and 20 with respect to DGND	-0.3	$V_{DD1} + 0.3$	V
$V_{3, 17}$	DC voltage at pins 3 and 17 with respect to AGND	-0.3	$V_{CC} + 0.3$	V
ΔV_{GND}	difference in voltage between AGND and DGND (these pins should be connected together)	-0.3	+0.3	V
T_{stg}	storage temperature	-55	+125	°C
T_{amb}	operating ambient temperature	-30	+85	°C

HANDLING

Inputs and outputs are protected against electrostatic discharge in normal handling. However, to be totally safe, it is desirable to take normal precautions appropriate to handling MOS devices.

Low-power dual frequency synthesizer for radio communications

UMA1015M

CHARACTERISTICS
 $V_{DD1} = V_{DD2} = 2.6$ to 5.5 V; $V_{CC} = 2.6$ to 6.0 V; $T_{amb} = 25$ °C; unless otherwise specified.

SYMBOL	PARAMETER	CONDITIONS	MIN.	TYP.	MAX.	UNIT
Supply; (V_{DD1}, V_{DD2} and V_{CC}) voltage doubler disabled, external supply on V_{CC}						
V_{DD1} , V_{DD2}	digital supply voltage	$V_{DD1} = V_{DD2}$	2.6	–	5.5	V
$I_{DD1} + I_{DD2}$	total digital supply current from V_{DD1} and V_{DD2}	$f_{XTAL} = 12.8$ MHz; both synthesizers on; $V_{DD1} = V_{DD2} = 3$ V	–	8.5	–	mA
		$f_{XTAL} = 12.8$ MHz; both synthesizers on; $V_{DD1} = V_{DD2} = 5.5$ V	–	–	12.5	mA
I_{DDpda} , I_{DDpdb}	total digital supply current from V_{DD1} and V_{DD2} with one synthesizer in power-down mode	$f_{XTAL} = 12.8$ MHz; one synthesizer powered down; $V_{DD1} = V_{DD2} = 3$ V	–	5.5	–	mA
		$f_{XTAL} = 12.8$ MHz; one synthesizer powered down; $V_{DD1} = V_{DD2} = 5.5$ V	–	–	7.5	mA
I_{DDpd}	digital supply current in power-down mode	both synthesizers powered down; $V_{HPD} = 0$ V	–	–	60	μ A
V_{CC}	charge pump supply voltage	$V_{CC} \geq V_{DD}$	2.6	–	6.0	V
I_{CC}	charge pump supply current	both synthesizers on and in lock; $f_{ref} = 12.5$ kHz	–	–	25	μ A
I_{CCpd}	charge pump supply current in power-down mode	both synthesizers powered down	–	–	25	μ A
Voltage doubler enabled						
I_{DD}	total digital supply current from V_{DD1} and V_{DD2}	$f_{XTAL} = 12.8$ MHz; both synthesizers on and in lock; $V_{DD1} = 3$ V; $f_{doubler} = 16$ MHz	–	8.5	12	mA
I_{DDpd}	total digital supply current in power-down mode from V_{DD1} and V_{DD2}	both synthesizers powered down; $V_{DD1} = 3$ V; $V_{HPD} = 0$ V	–	0.25	0.4	mA
V_{CCvd}	charge pump supply voltage	DC current drawn from $V_{CC} = 50$ μ A	$2V_{DD1} - 1.2$	$2V_{DD1} - 0.6$	6.0	V

Low-power dual frequency synthesizer for radio communications

UMA1015M

SYMBOL	PARAMETER	CONDITIONS	MIN.	TYP.	MAX.	UNIT
RF main divider input; RFA and RFB						
f_{RF}	RF input frequency		50	–	1100	MHz
$V_{RF(rms)}$	RF input signal voltage (RMS value; AC coupled)	$R_s = 50 \Omega$; $V_{DD1} = V_{DD2} = 2.6$ to 3.5 V; $f_{RF} = 400$ to 1100 MHz	50	–	250	mV
		$R_s = 50 \Omega$; $V_{DD1} = V_{DD2} = 3.5$ to 5.5 V; $f_{RF} = 400$ to 1100 MHz	100	–	250	mV
		$R_s = 50 \Omega$; $V_{DD1} = V_{DD2} = 2.6$ to 5.5 V; $f_{RF} = 50$ to 400 MHz	150	–	400	mV
Z_I	input impedance (real part)	$f_{RF} = 1$ GHz; indicative, not tested	–	300	–	Ω
C_I	input capacitance	indicative, not tested	–	1	–	pF
R_{pm}	principle main divider ratio		512	–	131071	
Reference divider input; f_{XTALIN}						
f_{XTALIN}	reference input frequency from crystal		3	–	35	MHz
$V_{XTALIN(rms)}$	sinusoidal input voltage (RMS value)		100	–	500	mV
Z_I	input impedance (real part)	$f_{XTALIN} = 12.8$ MHz; indicative, not tested	–	10	–	k Ω
C_I	input capacitance	indicative, not tested	–	1	–	pF
R_{rd}	reference divider ratio		8	–	4095	
Charge pump current setting resistor input; I_{SET}						
V_{SET}	voltage output on I_{SET}	$R_{SET} = 12$ to 60 k Ω	–	1.2	–	V
Charge pump outputs; CPA and CPB						
I_{CP}	charge pump sink or source current	$R_{SET} = 15$ k Ω ; CRA/CRB = logic 1; $I_{cp} = I_{SET} \times 24$; $V_{cp} = 0.4$ V to $V_{CC} - 0.5$ V	1.4	1.9	2.4	mA
		$R_{SET} = 15$ k Ω ; CRA/CRB = logic 0; $I_{cp} = I_{SET} \times 12$; $V_{cp} = 0.4$ V to $V_{CC} - 0.5$ V	0.7	0.96	1.2	mA
I_{LI}	charge pump off leakage current	$V_{cp} = 0.5V_{CC}$	–5	–	+5	nA

Low-power dual frequency synthesizer
for radio communications

UMA1015M

SYMBOL	PARAMETER	CONDITIONS	MIN.	TYP.	MAX.	UNIT
Logic input signal levels; DATA, CLK, \bar{E} and HPD						
V_{IH}	HIGH level input voltage	at logic 1	$0.7V_{DD1}$	–	$V_{DD1} + 0.3$	V
V_{IL}	LOW level input voltage	at logic 0	–0.3	–	$0.3V_{DD1}$	V
I_{bias}	input bias currents	at logic 1 or logic 0	–5	–	+5	μA
C_I	input capacitance	indicative, not tested	–	1	–	pF
Port outputs/Out-of-lock; P0/OOL, P1, P2, P3 and f_{XTALO} - open drain outputs						
V_{OL}	LOW level output voltage	$I_{sink} = 0.4 \text{ mA}$	–	–	0.4	V

SERIAL TIMING CHARACTERISTICS

$V_{DD1} = 3 \text{ V}$; $T_{amb} = 25 \text{ }^\circ\text{C}$ unless otherwise specified.

SYMBOL	PARAMETER	MIN.	TYP.	MAX.	UNIT
Serial programming clock; CLK					
t_r, t_f	input rise and fall times	–	10	40	ns
t_{cy}	clock period	100	–	–	ns
Enable programming; \bar{E}					
t_{START}	delay to rising clock edge	40	–	–	ns
t_{END}	delay from last falling clock edge	–20	–	–	ns
t_w	minimum inactive pulse width	4000	–	–	ns
$t_{SU;\bar{E}}$	enable set-up time to next clock edge	20	–	–	ns
Register serial input data; DATA					
$t_{SU;DAT}$	input data to clock set-up time	20	–	–	ns
$t_{HD;DAT}$	input data to clock hold time	20	–	–	ns

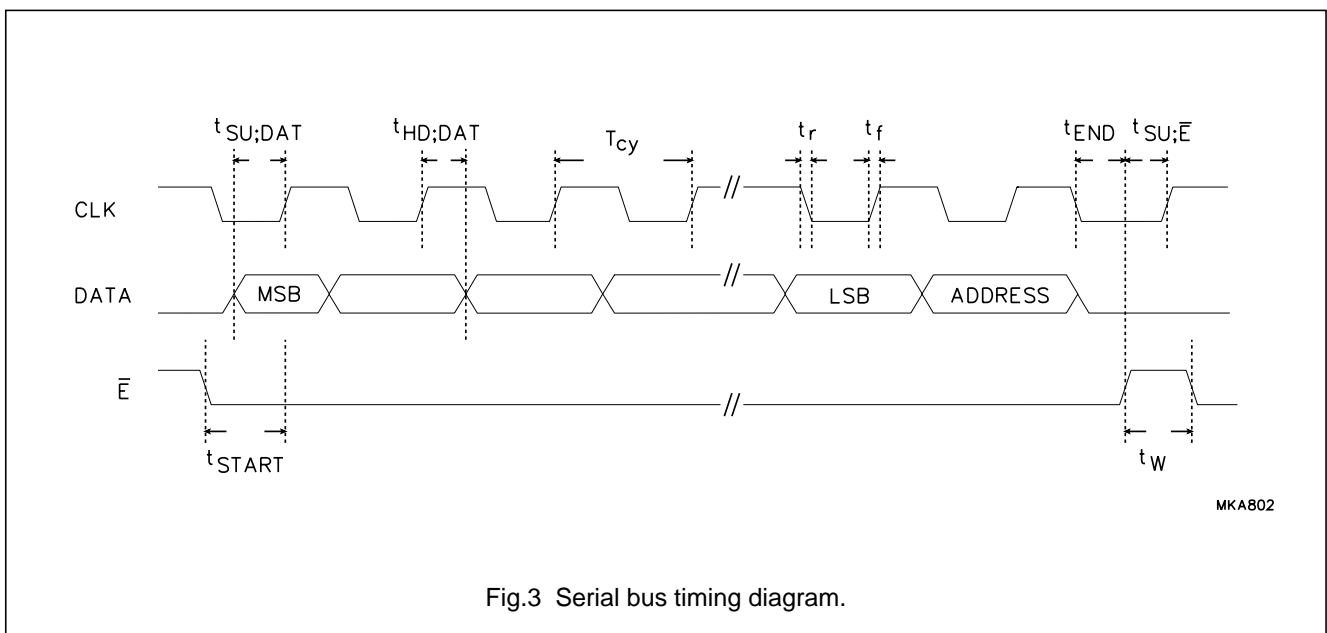
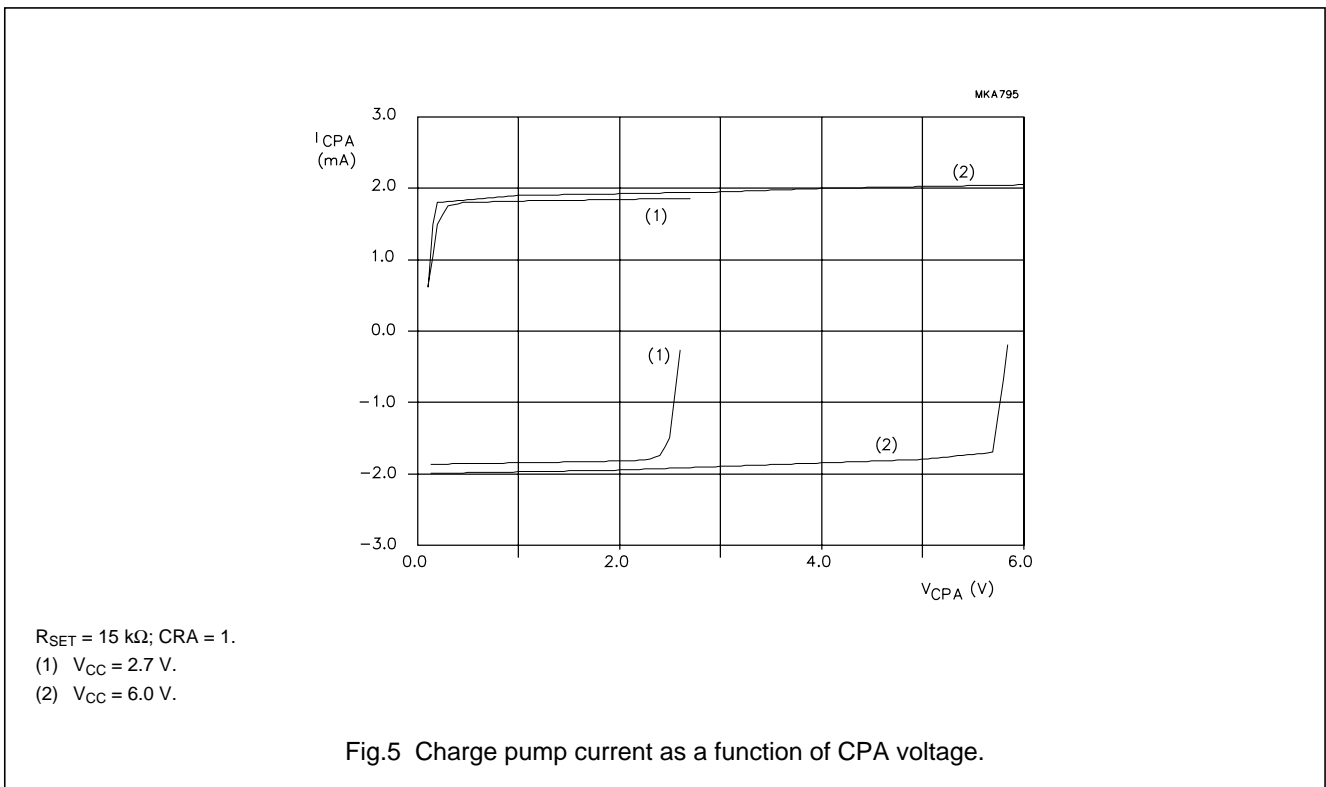
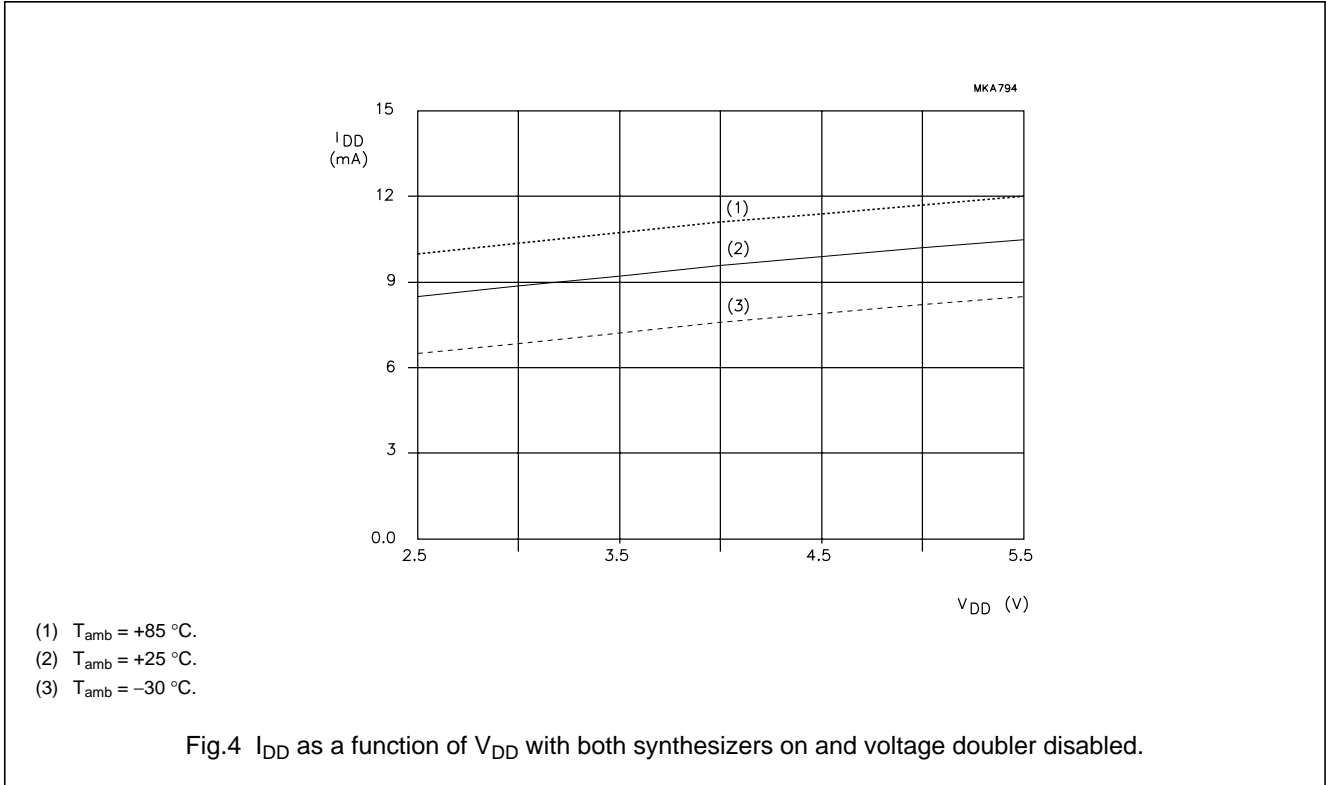

Fig.3 Serial bus timing diagram.

Low-power dual frequency synthesizer
for radio communications

UMA1015M

TYPICAL PERFORMANCE CHARACTERISTICS



Low-power dual frequency synthesizer
for radio communications

UMA1015M

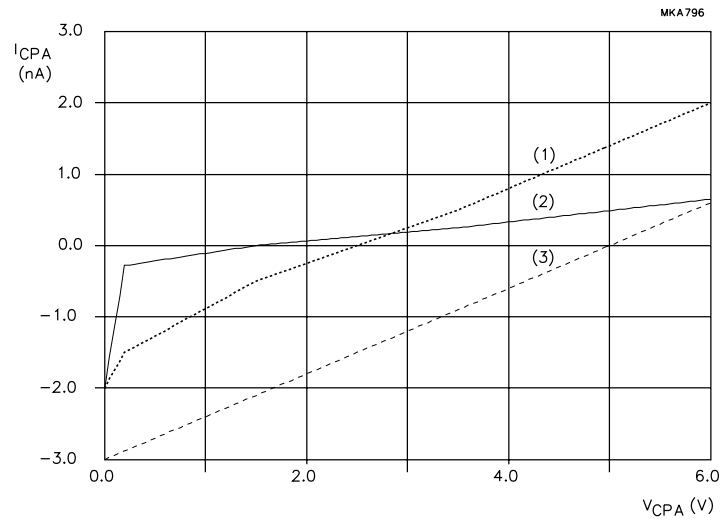

$R_{SET} = 15\text{ k}\Omega$; $CRA = 1$.

- (1) $T_{amb} = +85\text{ }^{\circ}\text{C}$.
- (2) $T_{amb} = +25\text{ }^{\circ}\text{C}$.
- (3) $T_{amb} = -30\text{ }^{\circ}\text{C}$.

Fig.6 Charge pump 3-state current as a function of CPA voltage.

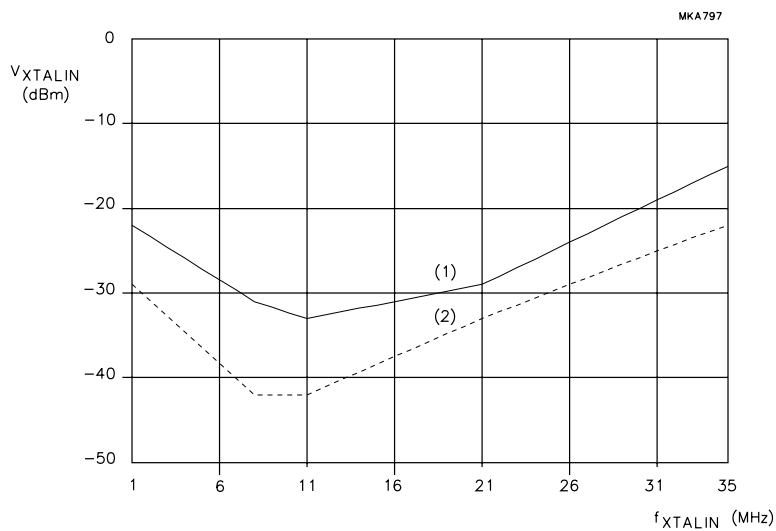

f_{XTALIN} externally terminated by $50\text{ }\Omega$ load; AC-coupled.

- (1) $V_{DD} = 5.5\text{ V}$.
- (2) $V_{DD} = 2.7\text{ V}$.

Fig.7 Crystal input sensitivity as a function of input frequency.

Low-power dual frequency synthesizer
for radio communications

UMA1015M

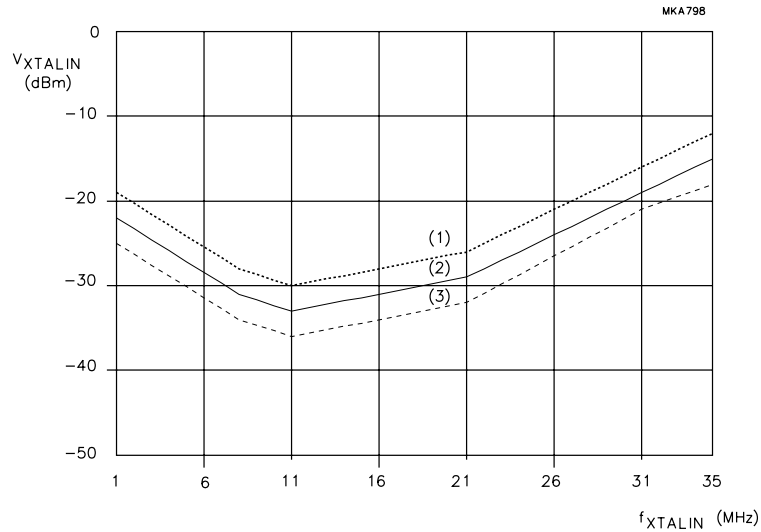

f_{XTALIN} externally terminated by 50 Ω load; AC-coupled.

- (1) T_{amb} = -30 °C.
- (2) T_{amb} = +25 °C.
- (3) T_{amb} = +85 °C.

Fig.8 Crystal input sensitivity as a function of input frequency with V_{DD} = 5.5 V.

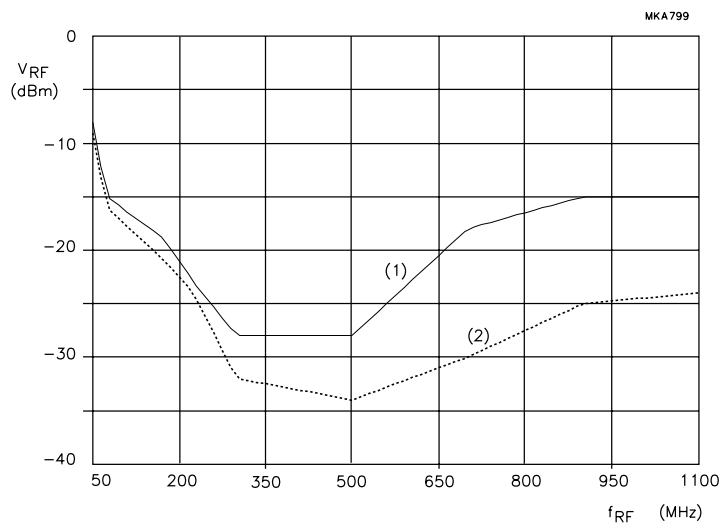

RF input externally terminated by 50 Ω load; AC-coupled.

- (1) V_{DD} = 5.5 V.
- (2) V_{DD} = 2.7 V.

Fig.9 RF input sensitivity as a function of input frequency.

Low-power dual frequency synthesizer
for radio communications

UMA1015M

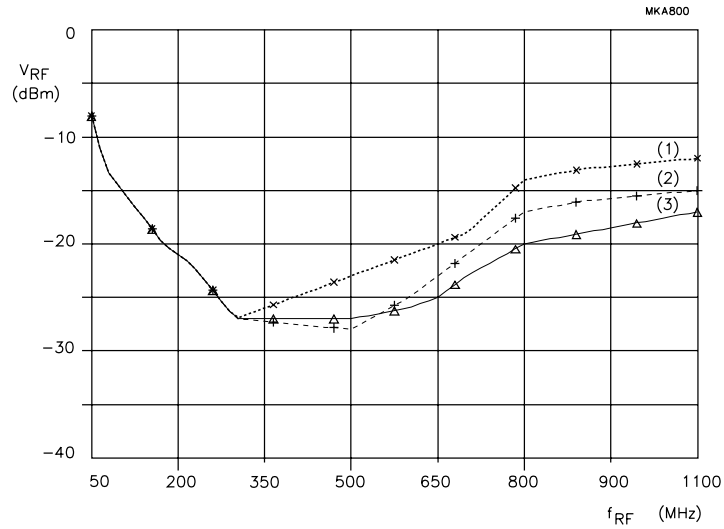

RF input externally terminated by 50 Ω load; AC-coupled.

- (1) T_{amb} = -30 °C.
- (2) T_{amb} = +25 °C.
- (3) T_{amb} = +85 °C.

Fig.10 RF input sensitivity as a function of input frequency with V_{DD} = 5.5 V.

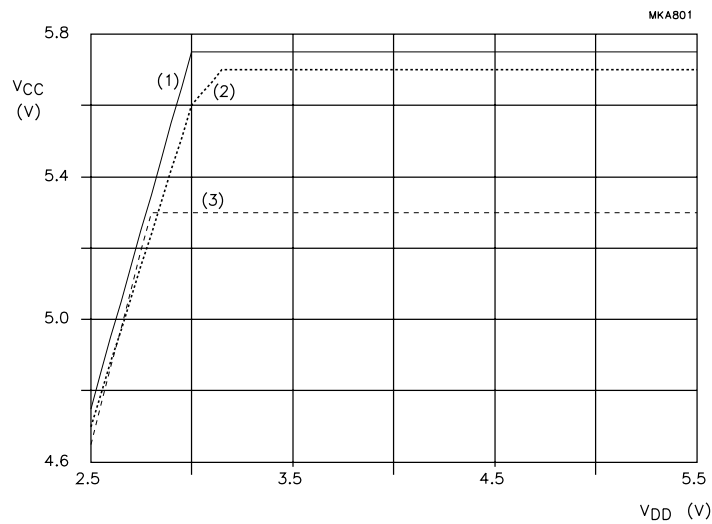

- (1) T_{amb} = -30 °C.
- (2) T_{amb} = +25 °C.
- (3) T_{amb} = +85 °C.

Fig.11 Typical charge pump supply voltage as a function of V_{DD} voltage with voltage doubler enabled.

Low-power dual frequency synthesizer
for radio communications

UMA1015M

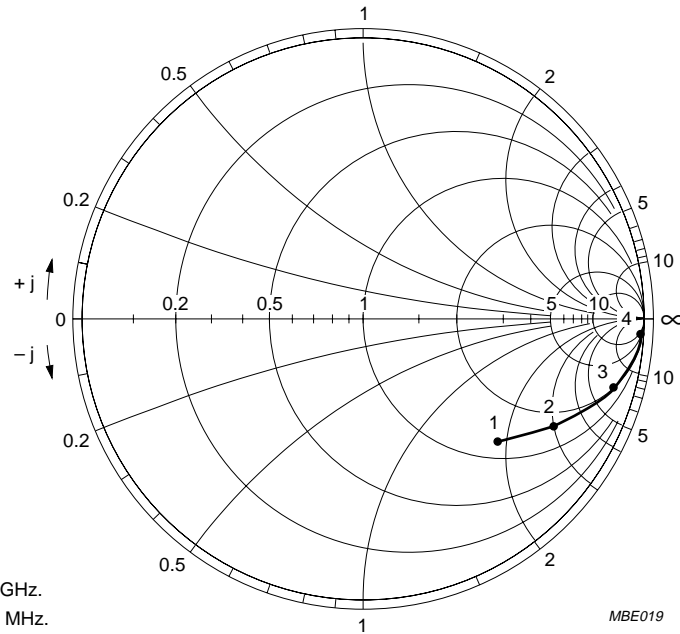

- (1) 68.316 Ω , -92.457 Ω at 1.1 GHz.
- (2) 85.914 Ω , -152.08 Ω at 800 MHz.
- (3) 102.83 Ω , -354.66 Ω at 400 MHz.
- (4) 853.75 Ω , -2.7735 k Ω at 50 MHz.

MBE019

Fig.12 Input impedance as a function of input frequency; synthesizer A.

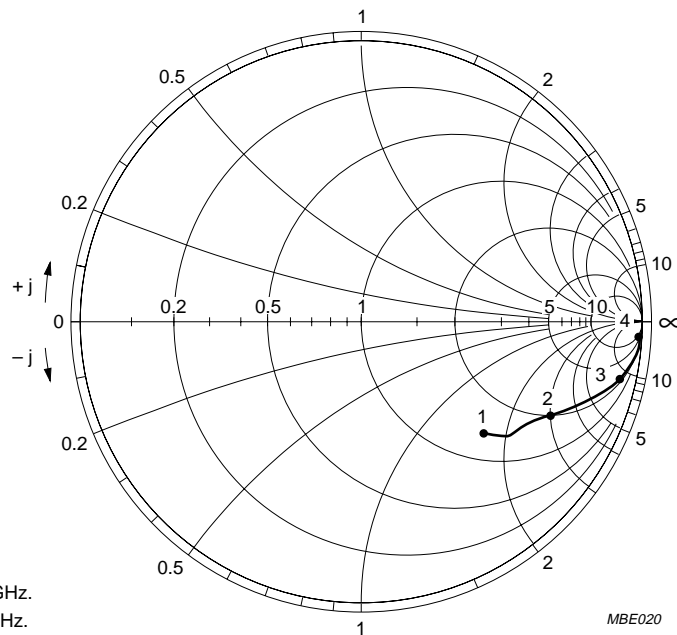

- (1) 69.293 Ω , -78.027 Ω at 1.1 GHz.
- (2) 100.2 Ω , -148.37 Ω at 800 MHz.
- (3) 128.22 Ω , -378.81 Ω at 400 MHz.
- (4) 674.25 Ω , -3.06 k Ω at 50 MHz.

MBE020

Fig.13 Input impedance as a function of input frequency; synthesizer B.

Low-power dual frequency synthesizer for radio communications

UMA1015M

APPLICATION INFORMATION

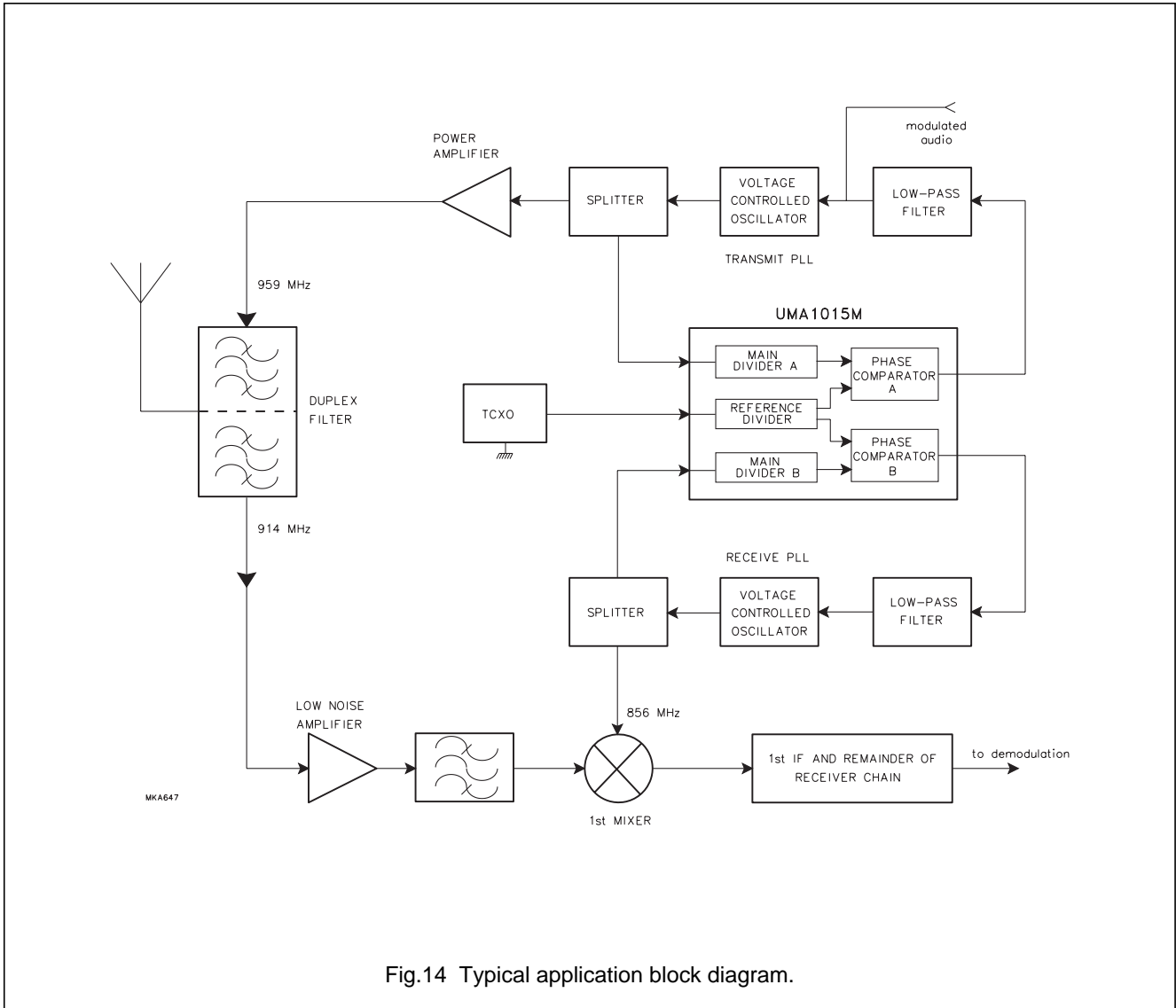

Fig.14 Typical application block diagram.

Low-power dual frequency synthesizer for radio communications

UMA1015M

PACKAGE OUTLINE

SSOP20: plastic shrink small outline package; 20 leads; body width 4.4 mm

SOT266-1

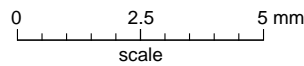
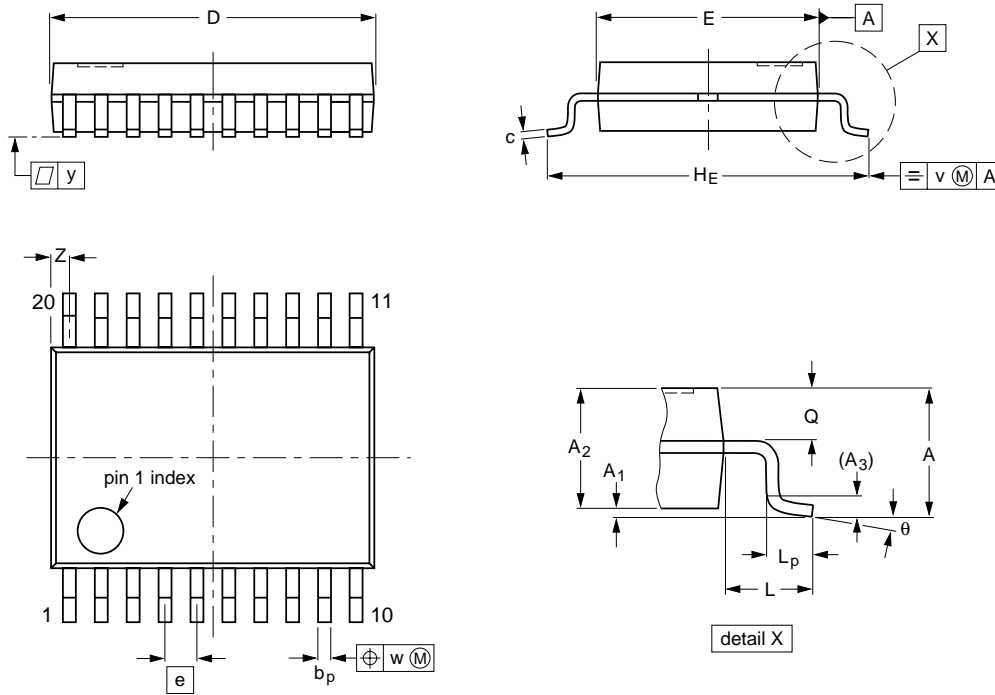

DIMENSIONS (mm are the original dimensions)

UNIT	A max.	A ₁	A ₂	A ₃	b _p	c	D ⁽¹⁾	E ⁽¹⁾	e	H _E	L	L _p	Q	v	w	y	Z ⁽¹⁾	θ
mm	1.5	0.15 0	1.4 1.2	0.25	0.32 0.20	0.20 0.13	6.6 6.4	4.5 4.3	0.65	6.6 6.2	1.0	0.75 0.45	0.65 0.45	0.2	0.13	0.1	0.48 0.18	10° 0°

Note

1. Plastic or metal protrusions of 0.20 mm maximum per side are not included.

OUTLINE VERSION	REFERENCES				EUROPEAN PROJECTION	ISSUE DATE
	IEC	JEDEC	EIAJ			
SOT266-1						90-04-05 95-02-25

Low-power dual frequency synthesizer for radio communications

UMA1015M

SOLDERING SO or SSOP

Introduction

There is no soldering method that is ideal for all IC packages. Wave soldering is often preferred when through-hole and surface mounted components are mixed on one printed-circuit board. However, wave soldering is not always suitable for surface mounted ICs, or for printed-circuits with high population densities. In these cases reflow soldering is often used.

This text gives a very brief insight to a complex technology. A more in-depth account of soldering ICs can be found in our "IC Package Databook" (order code 9398 652 90011).

Reflow soldering

Reflow soldering techniques are suitable for all SO and SSOP packages.

Reflow soldering requires solder paste (a suspension of fine solder particles, flux and binding agent) to be applied to the printed-circuit board by screen printing, stencilling or pressure-syringe dispensing before package placement.

Several techniques exist for reflowing; for example, thermal conduction by heated belt. Dwell times vary between 50 and 300 seconds depending on heating method. Typical reflow temperatures range from 215 to 250 °C.

Preheating is necessary to dry the paste and evaporate the binding agent. Preheating duration: 45 minutes at 45 °C.

Wave soldering

SO

Wave soldering techniques can be used for all SO packages if the following conditions are observed:

- A double-wave (a turbulent wave with high upward pressure followed by a smooth laminar wave) soldering technique should be used.
- The longitudinal axis of the package footprint must be parallel to the solder flow.
- The package footprint must incorporate solder thieves at the downstream end.

SSOP

Wave soldering is **not** recommended for SSOP packages. This is because of the likelihood of solder bridging due to closely-spaced leads and the possibility of incomplete solder penetration in multi-lead devices.

If wave soldering cannot be avoided, the following conditions must be observed:

- **A double-wave (a turbulent wave with high upward pressure followed by a smooth laminar wave) soldering technique should be used.**
- **The longitudinal axis of the package footprint must be parallel to the solder flow and must incorporate solder thieves at the downstream end.**

Even with these conditions, only consider wave soldering SSOP packages that have a body width of 4.4 mm, that is SSOP16 (SOT369-1) or SSOP20 (SOT266-1).

METHOD (SO OR SSOP)

During placement and before soldering, the package must be fixed with a droplet of adhesive. The adhesive can be applied by screen printing, pin transfer or syringe dispensing. The package can be soldered after the adhesive is cured.

Maximum permissible solder temperature is 260 °C, and maximum duration of package immersion in solder is 10 seconds, if cooled to less than 150 °C within 6 seconds. Typical dwell time is 4 seconds at 250 °C.

A mildly-activated flux will eliminate the need for removal of corrosive residues in most applications.

Repairing soldered joints

Fix the component by first soldering two diagonally-opposite end leads. Use only a low voltage soldering iron (less than 24 V) applied to the flat part of the lead. Contact time must be limited to 10 seconds at up to 300 °C. When using a dedicated G, all other leads can be soldered in one operation within 2 to 5 seconds at 270 to 320 °C.

Low-power dual frequency synthesizer for radio communications

UMA1015M

DEFINITIONS

Data sheet status	
Objective specification	This data sheet contains target or goal specifications for product development.
Preliminary specification	This data sheet contains preliminary data; supplementary data may be published later.
Product specification	This data sheet contains final product specifications.
Limiting values	
Limiting values given are in accordance with the Absolute Maximum Rating System (IEC 134). Stress above one or more of the limiting values may cause permanent damage to the device. These are stress ratings only and operation of the device at these or at any other conditions above those given in the Characteristics sections of the specification is not implied. Exposure to limiting values for extended periods may affect device reliability.	
Application information	
Where application information is given, it is advisory and does not form part of the specification.	

LIFE SUPPORT APPLICATIONS

These products are not designed for use in life support appliances, devices, or systems where malfunction of these products can reasonably be expected to result in personal injury. Philips customers using or selling these products for use in such applications do so at their own risk and agree to fully indemnify Philips for any damages resulting from such improper use or sale.

Low-power dual frequency synthesizer
for radio communications

UMA1015M

NOTES

Low-power dual frequency synthesizer
for radio communications

UMA1015M

NOTES

Low-power dual frequency synthesizer
for radio communications

UMA1015M

NOTES

Philips Semiconductors – a worldwide company

Argentina: IEROD, Av. Juramento 1992 - 14.b, (1428)
BUENOS AIRES, Tel. (541)786 7633, Fax. (541)786 9367

Australia: 34 Waterloo Road, NORTH RYDE, NSW 2113,
Tel. (02)805 4455, Fax. (02)805 4466

Austria: Triester Str. 64, A-1101 WIEN, P.O. Box 213,
Tel. (01)60 101-1236, Fax. (01)60 101-1211

Belgium: Postbus 90050, 5600 PB EINDHOVEN, The Netherlands,
Tel. (31)40 783 749, Fax. (31)40 788 399

Brazil: Rua do Rocio 220 - 5th floor, Suite 51,
CEP: 04552-903-SÃO PAULO-SP, Brazil.
P.O. Box 7383 (01064-970),
Tel. (011)821-2333, Fax. (011)829-1849

Canada: PHILIPS SEMICONDUCTORS/COMPONENTS:
Tel. (800) 234-7381, Fax. (708) 296-8556

Chile: Av. Santa Maria 0760, SANTIAGO,
Tel. (02)773 816, Fax. (02)777 6730

Colombia: IPRELENZO LTDA, Carrera 21 No. 56-17,
77621 BOGOTA, Tel. (571)249 7624/(571)217 4609,
Fax. (571)217 4549

Denmark: Prags Boulevard 80, PB 1919, DK-2300
COPENHAGEN S, Tel. (032)88 2636, Fax. (031)57 1949

Finland: Sinikalliontie 3, FIN-02630 ESPOO,
Tel. (358)0-615 800, Fax. (358)0-61580 920

France: 4 Rue du Port-aux-Vins, BP317,
92156 SURESNES Cedex,
Tel. (01)4099 6161, Fax. (01)4099 6427

Germany: P.O. Box 10 63 23, 20043 HAMBURG,
Tel. (040)3296-0, Fax. (040)3296 213.

Greece: No. 15, 25th March Street, GR 17778 TAVROS,
Tel. (01)4894 339/4894 911, Fax. (01)4814 240

Hong Kong: PHILIPS HONG KONG Ltd., 15/F Philips Ind. Bldg.,
24-28 Kung Yip St., KWAI CHUNG, N.T.,
Tel. (852)424 5121, Fax. (852)480 6960/480 6009

India: Philips INDIA Ltd, Shivsagar Estate, A Block,
Dr. Annie Besant Rd. Worli, Bombay 400 018
Tel. (022)4938 541, Fax. (022)4938 722

Indonesia: Philips House, Jalan H.R. Rasuna Said Kav. 3-4,
P.O. Box 4252, JAKARTA 12950,
Tel. (021)5201 122, Fax. (021)5205 189

Ireland: Newstead, Clonskeagh, DUBLIN 14,
Tel. (01)7640 000, Fax. (01)7640 200

Italy: PHILIPS SEMICONDUCTORS S.r.l.,
Piazza IV Novembre 3, 20124 MILANO,
Tel. (0039)2 6752 2531, Fax. (0039)2 6752 2557

Japan: Philips Bldg 13-37, Kohnan2-chome, Minato-ku, TOKYO 108,
Tel. (03)3740 5130, Fax. (03)3740 5077

Korea: Philips House, 260-199 Itaewon-dong,
Yongsan-ku, SEOUL, Tel. (02)709-1412, Fax. (02)709-1415

Malaysia: No. 76 Jalan Universiti, 46200 PETALING JAYA,
SELANGOR, Tel. (03)750 5214, Fax. (03)757 4880

Mexico: 5900 Gateway East, Suite 200, EL PASO, TX 79905,
Tel. 9-5(800)234-7381, Fax. (708)296-8556

Netherlands: Postbus 90050, 5600 PB EINDHOVEN, Bldg. VB
Tel. (040)783749, Fax. (040)788399

New Zealand: 2 Wagener Place, C.P.O. Box 1041, AUCKLAND,
Tel. (09)849-4160, Fax. (09)849-7811

Norway: Box 1, Manglerud 0612, OSLO,
Tel. (022)74 8000, Fax. (022)74 8341

Pakistan: Philips Electrical Industries of Pakistan Ltd.,
Exchange Bldg. ST-2/A, Block 9, KDA Scheme 5, Clifton,
KARACHI 75600, Tel. (021)587 4641-49,
Fax. (021)577035/5874546

Philippines: PHILIPS SEMICONDUCTORS PHILIPPINES Inc,
106 Valero St. Salcedo Village, P.O. Box 2108 MCC, MAKATI,
Metro MANILA, Tel. (02)810 0161, Fax. (02)817 3474

Portugal: PHILIPS PORTUGUESA, S.A.,
Rua dr. António Loureiro Borges 5, Arquiparque - Miraflores,
Apartado 300, 2795 LINDA-A-VELHA,
Tel. (01)4163160/4163333, Fax. (01)4163174/4163366

Singapore: Lorong 1, Toa Payoh, SINGAPORE 1231,
Tel. (65)350 2000, Fax. (65)251 6500

South Africa: S.A. PHILIPS Pty Ltd.,
195-215 Main Road Martindale, 2092 JOHANNESBURG,
P.O. Box 7430, Johannesburg 2000,
Tel. (011)470-5911, Fax. (011)470-5494.

Spain: Balmes 22, 08007 BARCELONA,
Tel. (03)301 6312, Fax. (03)301 42 43

Sweden: Kottbygatan 7, Akalla. S-164 85 STOCKHOLM,
Tel. (0)8-632 2000, Fax. (0)8-632 2745

Switzerland: Allmendstrasse 140, CH-8027 ZÜRICH,
Tel. (01)488 2211, Fax. (01)481 77 30

Taiwan: PHILIPS TAIWAN Ltd., 23-30F, 66, Chung Hsiao West
Road, Sec. 1, Taipei, Taiwan ROC, P.O. Box 22978,
TAIPEI 100, Tel. (02)388 7666, Fax. (02)382 4382

Thailand: PHILIPS ELECTRONICS (THAILAND) Ltd.,
209/2 Sanpavuth-Bangna Road Prakanong,
Bangkok 10260, THAILAND,
Tel. (662)398-0141, Fax. (662)398-3319

Turkey: Talatpasa Cad. No. 5, 80640 GÜLTEPE/ISTANBUL,
Tel. (0212)279 27 70, Fax. (0212)282 67 07

United Kingdom: Philips Semiconductors LTD.,
276 Bath Road, Hayes, MIDDLESEX UB3 5BX,
Tel. (0181)730-5000, Fax. (0181)754-8421

United States: 811 East Arques Avenue, SUNNYVALE,
CA 94088-3409, Tel. (800)234-7381, Fax. (708)296-8556

Uruguay: Coronel Mora 433, MONTEVIDEO,
Tel. (02)70-4044, Fax. (02)92 0601

Internet: <http://www.semiconductors.philips.com/ps/>

For all other countries apply to: Philips Semiconductors,
International Marketing and Sales, Building BE-p,
P.O. Box 218, 5600 MD EINDHOVEN, The Netherlands,
Telex 35000 phtcnl, Fax. +31-40-724825

SCD40 © Philips Electronics N.V. 1995

All rights are reserved. Reproduction in whole or in part is prohibited without the prior written consent of the copyright owner.

The information presented in this document does not form part of any quotation or contract, is believed to be accurate and reliable and may be changed without notice. No liability will be accepted by the publisher for any consequence of its use. Publication thereof does not convey nor imply any license under patent- or other industrial or intellectual property rights.

Printed in The Netherlands

413061/1500/03/pp24

Date of release: 1995 Jun 22

Document order number:

9397 750 00177