

Datasheet

Multi-Rate (2 Gbps) Multi-Mode SFP Transceivers

SFP-DGD-SX



Features

- SFP transceiver
- Data Rates: 1062 - 2125 Mbps
- Protocols:
 - Gigabit Ethernet
 - 1 Gbps Fibre Channel
 - 2 Gbps Fibre Channel
- Multi-mode fiber
- 850 nm
- 0 to 550 m on 50/125 µm MMF
- 0 to 300 m on 62.5/125 µm MMF
- Duplex LC connector
- Digital Diagnostics (SFF-8472)
- Hot-swap
- Compliances (see last page for details)

Overview

Small Form-Factor Pluggable (SFP) interfaces from MRV Communications provide flexible high speed links in a small industry standard package. They deliver the deployment options and inventory control that network administrators demand for growing networks.

SFPs are designed to Multi-Source Agreement (MSA) standards to ensure network equipment compatibility. They are a perfect addition to MRV's extensive lines of networking equipment.

Visit the MRV website at www.mrv.com or contact your nearest authorized MRV Communications dealer for more information.

Specifications Overview

Data Rate	1062 - 2125 Mbps
Tx Wavelength	850 nm
Tx Power (Minimum)	-9 dBm
Tx Disable	Yes
Rx Wavelength	770 - 860 nm
Rx Sensitivity	-18 dBm
Rx Saturation	0 dBm
Operating Temperature Range	-20 to 85 °C
Power Consumption	1 Watt

Datasheet

Optical Specifications

Parameter	Symbol	Minimum	Maximum	Unit	Note
Transmitter					
Output Optical Power: 50 or 62.5 MMF	P _{OUT}	-9	-3	dBm	1
Optical Wavelength	λ	830	860	nm	-
Spectral Width	σ	-	0.85	nm	-
Optical Modulation Amplitude @ 2.125 Gbps	OMA	196	-	μW	2
Optical Modulation Amplitude @ 1.0625 Gbps	OMA	156	-	μW	2
Optical Rise/Fall Time	t _r , t _f	-	150	ps	3
Relative Intensity Noise	RIN	-	-120	dB/Hz	-
Deterministic Jitter Contribution	TX Δ DJ	-	56.5	ps	4
Total Jitter Contribution	TX Δ TJ	-	119	ps	5
Optical Extinction Ratio @ 1.25 Gbps	ER	9	-	dB	-
Receiver					
Receiver Sensitivity @ 1.0625 Gbps	R _{SENSr}	-	-20	dBm	6
Receiver Sensitivity @ 2.125 Gbps	R _{SENS2}	-	-18	dBm	6
Receiver Sensitivity @ 1.25 Gbps	R _{SENS1}	-	-20	dBm	7
Receiver Power	RX _{MAX}	-	0	dBm	-
Receiver Electrical 3 dB cutoff frequency	-	-	1500	MHz	-
Optical Center Wavelength	λ _C	770	860	nm	-
Optical Return Loss	-	12	-	dB	-
LOS De-Assert	LOS _D	-	-20	dBm	-
LOS Assert	LOS _A	-30	-	dBm	-
LOS Hysteresis	-	0.5	-	dB	-

- Notes:**
- Class 1 Laser Safety per FDA/CDRH, (IEC) and EN 60825-1 laser safety regulations.
 - Equivalent extinction ratio specification for Fibre Channel. Allows smaller ER at higher average power.
 - Unfiltered, 20-80%. Complies with FC 1G and 2G eye mask when filtered.
 - Measured with DJ-free data input signal. In actual application, output DJ will be the sum of input DJ and Δ DJ.
 - If measured with TJ-free data input signal. In actual application, output TJ will be given by

$$TJ_{OUT} = DJ_{IN} + \Delta DJ + \sqrt{(TJ_{IN} - DJ_{IN})^2 + (\Delta TJ - \Delta DJ)^2}$$

- Specifications are for 50 micrometer or 62.5 micrometer fiber.
- As measured with 9 dB extinction ratio.

Datasheet

Digital Diagnostics Specifications

Parameter	Symbol	Minimum	Maximum	Unit	Note
Accuracy					
Internally Measured Transceiver Temperature	DD _{Temperature}	-	± 3	°C	-
Internally Measured Transceiver Supply Voltage	DD _{Voltage}	-	± 100	mV	-
Measured TX Bias Current	DD _{Bias}	-	± 10	%	1
Measured TX Output Power	DD _{Tx-Power}	-	± 3	dB	-
Measured RX Received Average Optical Power	DD _{Rx-Power}	-	± 3	dB	-
Dynamic Range for Rated Accuracy					
Internally Measured Transceiver Temperature	DD _{Temperature}	-20	85	°C	-
Internally Measured Transceiver Supply Voltage	DD _{Voltage}	3.0	3.6	V	-
Measured TX Bias Current	DD _{Bias}	0	20	mA	-
Measured TX Output Power	DD _{Tx-Power}	-9	-3	dBm	-
Measured RX Received Average Optical Power	DD _{Rx-Power}	-20	0	dBm	-
Max Reporting Range					
Internally Measured Transceiver Temperature	DD _{Temperature}	-40	125	°C	-
Internally Measured Transceiver Supply Voltage	DD _{Voltage}	2.8	4.0	V	-
Measured TX Bias Current	DD _{Bias}	0	20	mA	-
Measured TX Output Power	DD _{Tx-Power}	-10	-3	dBm	-
Measured RX Received Average Optical Power	DD _{Rx-Power}	-22	0	dBm	-

Notes: 1. Accuracy of Measured Tx Bias Current is 10% of the actual Bias Current from the laser driver to the laser.

General Specifications

Parameter	Symbol	Minimum	Maximum	Unit	Note
Data Rate	BR	1062	2125	Mbps	1
Bit Error Rate	BER	-	10 ⁻¹²	-	4
Fiber Length on 50/125 µm MMF	L	-	550	m	2
			300		3
Fiber Length on 62.5/125 µm MMF	L	-	300	m	2
			150		3

Notes:

1. Gigabit Ethernet and 1G/2G Fibre Channel compatible, per IEEE 802.3 and FC-P1-2 Rev. 5.0 respectively.
2. At 1.0625 Gbps Fibre Channel and 1.25 Gbps Gigabit Ethernet data rates.
3. At 2.125 Gbps Fibre Channel data rates.
4. 2.125 Gbps with PRBS 2⁷ - 1.

Datasheet

Absolute Maximum Ratings*

Parameter	Symbol	Minimum	Maximum	Unit	Note
Maximum Supply Voltage	V_{CC}	-0.5	4.0	V	-
Case Operating Temperature	T_A	-20	85	°C	-
Storage Temperature	T_S	-40	85	°C	-
Relative Humidity (Non-Condensing)	RH	0	85	%	-

*Exceeding the limits listed in the table may damage the transceiver module permanently

Electrical Specifications

Parameter	Symbol	Minimum	Maximum	Unit	Note
Supply Voltage	V_{CC}	3.00	3.60	V	-
Supply Current	I_{CC}	-	240	mA	-
Transmitter					
Input Differential Impedance	R_{in}	80	120	Ω	1
Single Ended Data Input Swing	V_{in} , pp	250	1200	mV	2
Transmit Disable Voltage	V_D	2	V_{CC}	V	3
Transmit Enable Voltage	V_{EN}	V_{ee}	$V_{ee} + 0.8$	V	-
Receiver					
Single Ended Data Output Swing	V_{out} , pp	250	550	mV	4
Data Output Rise Time	t_r	-	175	ps	5
Data Output Fall Time	t_f	-	175	ps	5
Mask Margin	-	0	-	%	-
LOS Fault	$V_{LOS\ fault}$	2	$V_{CC\ HOST}$	V	6
LOS Normal	$V_{LOS\ norm}$	V_{ee}	$V_{ee} + 0.5$	V	6
Power Supply Rejection	PSR	100	-	mVpp	7
Deterministic Jitter Contribution	$RX \Delta DJ$	-	51.7	ps	8
Total Jitter Contribution = 4.25 Gbps	$RX \Delta TJ$	-	122.4	ps	9

- Notes:**
1. Connected directly to TX data input pins. AC coupling from pins into laser driver IC.
 2. We recommend <600 mV for best EMI performance.
 3. Or open circuit.
 4. Into 100 ohm differential termination.
 5. 20 – 80 %
 6. LOS is an open collector output. Should be pulled up with 4.7 k - 10 kohms on the host board. Normal operation is logic 0; loss of signal is logic 1. Maximum pull-up voltage is 5.5 V.
 7. Receiver sensitivity is compliant with a power supply sinusoidal modulation of 20 Hz to 1.5 MHz up to specified value applied through the recommended power supply filtering network.
 8. Typical peak-to-peak jitter (=6*RMS width of Jitter).
 9. Measured with DJ-free data input signal. In actual application, output DJ will be the sum of input DJ and ΔDJ .

Datasheet

Pin Descriptions

Pin	Function	Name/Description	Note
1	V _{EET}	Transmitter Ground (Common with Receiver Ground)	1
2	T _{FAULT}	Transmitter Fault. Not Supported.	-
3	T _{DIS}	Transmitter Disable. Laser Output Disabled on High or Open.	2
4	MOD_DEF(2)	Module Definition 2. Data Line for Serial ID.	3
5	MOD_DEF(1)	Module Definition 1. Clock Line for Serial ID.	3
6	MOD_DEF(0)	Module Definition 0. Grounded Within the Module.	3
7	Rate Select	No Connection Required.	4
8	LOS	Loss of Signal Indication. Logic 0 Indicates Normal Operation.	5
9	V _{EER}	Receiver Ground (Common with Transmitter Ground)	1
10	V _{EER}	Receiver Ground (Common with Transmitter Ground)	1
11	V _{EER}	Receiver Ground (Common with Transmitter Ground)	1
12	RD-	Receiver Inverted DATA Out. AC Coupled.	-
13	RD+	Receiver Non-Inverted DATA Out. AC Coupled.	-
14	V _{EER}	Receiver Ground (Common with Transmitter Ground)	1
15	V _{CCR}	Receiver Power Supply	-
16	V _{CCT}	Transmitter Power Supply	-
17	V _{EET}	Transmitter Ground (Common with Receiver Ground)	1
18	TD+	Transmitter Non-Inverted DATA In. AC Coupled.	-
19	TD-	Transmitter Inverted DATA In. AC Coupled.	-
20	V _{EET}	Transmitter Ground (Common with Receiver Ground)	1

- Notes:**
1. Circuit ground is internally isolated from chassis ground.
 2. Laser output disabled on T_{DIS} > 2.0 V or open, enabled on T_{DIS} < 0.8 V.
 3. Should be pulled up with 4.7 k - 10 kohms on host board to a voltage between 2.0 V and 3.6 V. MOD_DEF(0) pulls line low to indicate module is plugged in.
 4. Transceivers operate at 1G and 2G Fibre Channel, and Gigabit Ethernet data rates and respective protocols without active control.
 5. LOS is open collector output. Should be pulled up with 4.7k - 10 kohms on host board to a voltage between 2.0 V and 3.6 V. Logic 0 indicates normal operation; logic 1 indicates loss of signal.

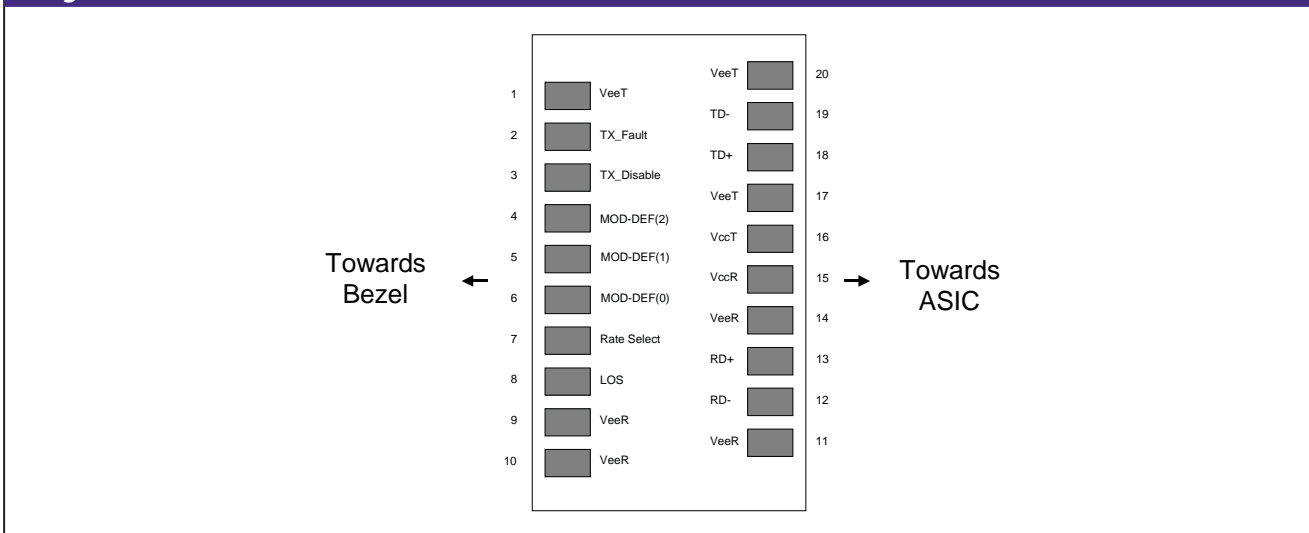
Diagram of Host Board Connector Block Pin Numbers and Names

Datasheet

Mechanical Dimensions

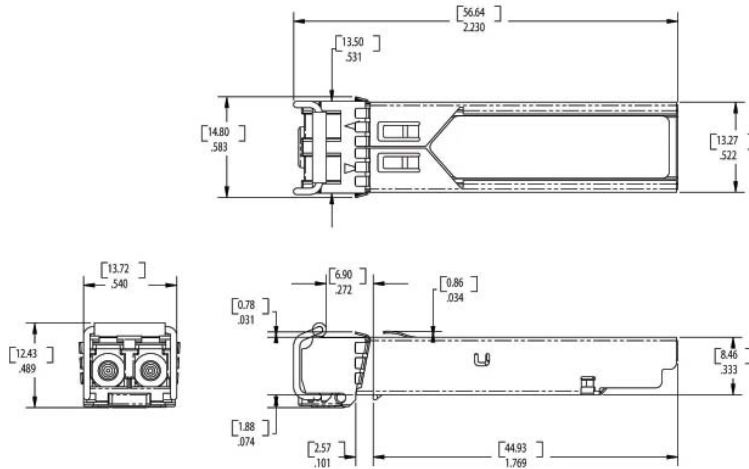

Ordering Information

Model	Description	Data Rate (Mbps)	Wavelength (nm)	Connector	Bail Latch Color	Maximum Distance Range (m)
SFP-DGD-SX	2 Gigabit Short-Wavelength SFP Transceiver	1062 - 2125	850	Duplex LC	Black	0 - 550

Regulatory and Industry Compliances

Class 1 Laser Product, Complies with 21CFR 1040.10, 1040.11 and EN 60825;
 Certified by one or more of the following agencies: TÜV, UL, CSA;
 RoHS Directive; China RoHS; California RoHS Law, REACH Directive SVHC; WEEE Directive
 The Quality Management System is certified to ISO 9001 by QMI-SAI Global
 The Environmental Management System is in compliance with ISO 14001

Warnings

Handling Precautions: This device is susceptible to damage as a result of electrostatic discharge (ESD). A static free environment is highly recommended. Follow guidelines according to proper ESD procedures.

Laser Safety: Radiation emitted by laser devices can be dangerous to human eyes. Avoid eye exposure to direct or indirect radiation.

MRV has more than 50 offices throughout the world. Addresses, phone numbers and fax numbers are listed at www.mrv.com. Please e-mail us at sales@mrv.com or call us for assistance.

MRV Los Angeles
 20415 Nordhoff St.
 Chatsworth, CA 91311
 800-338-5316
 818-773-0900

MRV Boston
 295 Foster St.
 Littleton, MA 01460
 800-338-5316
 978-952-4700

MRV International
 Business Park Moerfelden
 Waldeckerstrasse 13
 64546 Moerfelden-Walldorf
 Germany
 Tel. (49) 6105/2070
 Fax (49) 6105/207-100

All statements, technical information and recommendations related to the products herein are based upon information believed to be reliable or accurate. However, the accuracy or completeness thereof is not guaranteed, and no responsibility is assumed for any inaccuracies. Please contact MRV Communications for more information. MRV Communications and the MRV Communications logo are trademarks of MRV Communications, Inc. Other trademarks are the property of their respective holders.