

STYN225(S) thru STYN1025(S)

Discrete Thyristors(SCRs)

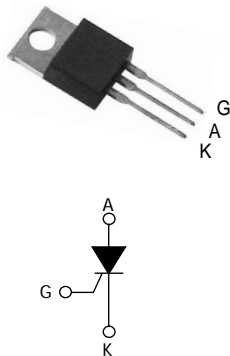

Dimensions TO-220AB

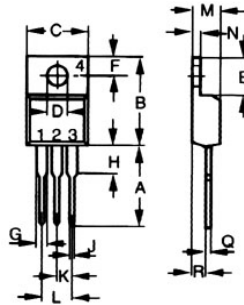

Dim.	Inches		Millimeter	
	Min.	Max.	Min.	Max.
A	0.500	0.550	12.70	13.97
B	0.580	0.630	14.73	16.00
C	0.390	0.420	9.91	10.66
D	0.139	0.161	3.54	4.08
E	0.230	0.270	5.85	6.85
F	0.100	0.125	2.54	3.18
G	0.045	0.065	1.15	1.65
H	0.110	0.230	2.79	5.84
J	0.025	0.040	0.64	1.01
K	0.100	BSC	2.54	BSC
M	0.170	0.190	4.32	4.82
N	0.045	0.055	1.14	1.39
Q	0.014	0.022	0.35	0.56
R	0.090	0.110	2.29	2.79

Dimensions TO-263(D²PAK)

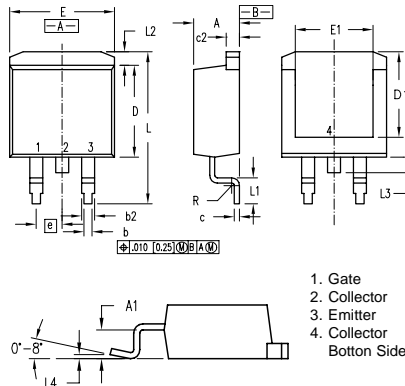
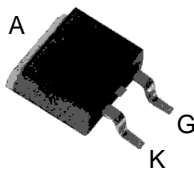

Dim.	Millimeter		Inches	
	Min.	Max.	Min.	Max.
A	4.06	4.83	.160	.190
A1	2.03	2.79	.080	.110
b	0.51	0.99	.020	.039
b2	1.14	1.40	.045	.055
c	0.46	0.74	.018	.029
c2	1.14	1.40	.045	.055
D	8.64	9.65	.340	.380
D1	8.00	8.89	.315	.350
E	9.65	10.29	.380	.405
E1	6.22	8.13	.245	.320
e	2.54 BSC		.100 BSC	
L	14.61	15.88	.575	.625
L1	2.29	2.79	.090	.110
L2	1.02	1.40	.040	.055
L3	1.27	1.78	.050	.070
L4	0	0.20	0	.008
R	0.46	0.74	.018	.029

ABSOLUTE RATINGS (limiting values)

Symbol	Parameter		Value	Unit
$I_{T(RMS)}$	RMS on-state current (180° conduction angle)		$T_c = 100^\circ C$ 25	A
$I_{T(AV)}$	Average on-state current (180° conduction angle)		$T_c = 100^\circ C$ 16	A
I_{TSM}	Non repetitive surge peak on-state current	$t_p = 8.3 \text{ ms}$	$T_j = 25^\circ C$ 314	A
		$t_p = 10 \text{ ms}$		
I_t^2	I_t^2 Value for fusing	$t_p = 10 \text{ ms}$	$T_j = 25^\circ C$ 450	A ² s
dI/dt	Critical rate of rise of on-state current $I_G = 2 \times I_{GT}$, $t_r \leq 100 \text{ ns}$	F = 60 Hz	$T_j = 125^\circ C$ 50	A/ μ s
I_{GM}	Peak gate current	$t_p = 20 \mu\text{s}$	$T_j = 125^\circ C$ 4	A
$P_{G(AV)}$	Average gate power dissipation		$T_j = 125^\circ C$ 1	W
T_{stg} T_j	Storage junction temperature range Operating junction temperature range		- 40 to + 150 - 40 to + 125	°C
V_{RGM}	Maximum peak reverse gate voltage (for TN8 & TYN only)		5	V



STYN225(S) thru STYN1025(S)

Discrete Thyristors(SCRs)

ELECTRICAL CHARACTERISTICS (T_j = 25°C, unless otherwise specified)

■ STANDARD

Symbol	Test Conditions			TYNx08(S)	Unit
I _{GT}	V _D = 12 V R _L = 33 W	MIN.		4	mA
		MAX.		40	
V _{GT}		MAX.		1.3	V
V _{GD}	V _D = V _{DRM} R _L = 3.3 kW	T _j = 125°C	MIN.	0.2	V
I _H	I _T = 500mA Gate open		MAX.	50	mA
I _L	I _G = 1.2 I _{GT}		MAX.	90	mA
dV/dt	V _D = 67 % V _{DRM} Gate open	T _j = 125°C	MIN.	1000	V/μs
V _{TM}	I _{TM} = 16 A t _p = 380 μs	T _j = 25°C	MAX.	1.6	V
V _{t0}	Threshold voltage	T _j = 125°C	MAX.	0.77	V
R _d	Dynamic resistance	T _j = 125°C	MAX.	14	mW
I _{DRM} I _{RRM}	V _{DRM} = V _{RRM}	T _j = 25°C	MAX.	5	μA
		T _j = 125°C		4	mA

THERMAL RESISTANCES

Symbol	Parameter		Value	Unit
R _{th(j-c)}	Junction to case (DC)		1.0	°C/W
R _{th(j-a)}	Junction to ambient (DC)		TO-220AB	°C/W
		S = 1.0 cm ²	TO-263	

S= copper surface under tab

PRODUCT SELECTOR

Part Number	Voltage (xxx)	Sensitivity	Package
STYNx25S	200~~1000	40 mA	TO-263
STYNx25	200~~1000	40 mA	TO-220AB

OTHER INFORMATION

Part Number	Marking	Weight	Base Quantity	Packing mode
STYNx25S	STYNx25S	0.5 g	50	Tube
STYNx25	STYNx25	2.3 g	250	Bulk

Note: x = voltage

