

Radar Pulsed Power Transistor - 100 Watts, 1.1-1.3 GHz, 3μs Pulse, 30% Duty



Features

- NPN Silicon Microwave Power Transistor
- Common Base Configuration
- Broadband Class C Operation
- High Efficiency Interdigitated Geometry
- Diffused Emitter Ballasting Resistors
- Gold Metalization System
- Internal Input and Output Impedance Matching
- Hermetic Metal/Ceramic Package

Description

M/A-COM's PH1113-100 is a silicon bipolar NPN power transistor intended for use in L-band 1.1 - 1.3 GHz pulsed radars. Designed for common-base, class C, broadband pulsed power applications, the PH1113-100 can produce 25 watts of output power with short pulse length (3μs) at 30 percent duty cycle. The transistor is housed in a 2-lead rectangular metal-ceramic flange package, with internal input and output impedance matching networks. Diffused emitter ballast resistors and gold metalization assure ruggedness and long-term reliability.

Outline Drawing¹

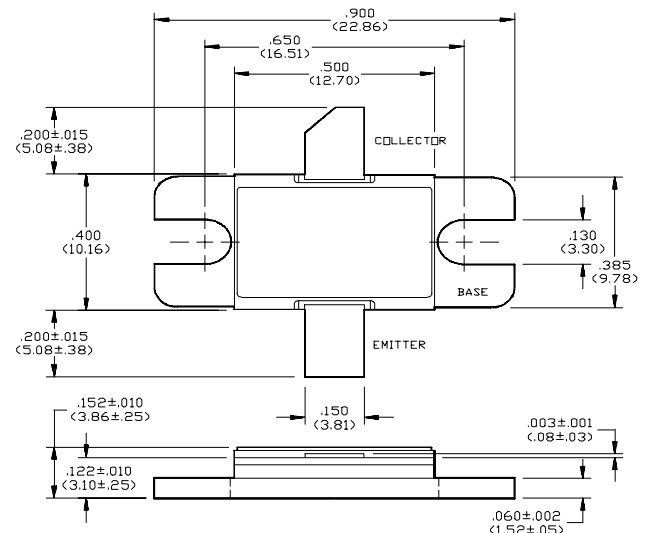

Notes: (unless otherwise specified)

1. Tolerances are: inches ± .005" (millimeters ± 0.13mm)

Broadband Test Fixture Impedance

F (GHz)	Z _{IF} (Ω)	Z _{OF} (Ω)
1.1	5.8 - j3.4	3.0 - j1.7
1.2	5.6 - j1.8	3.0 - j1.5
1.3	5.9 - j0.4	2.8 - j1.3

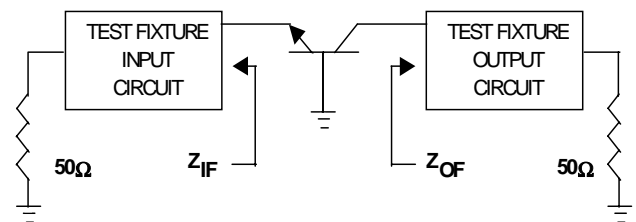

Absolute Maximum Rating at 25°C

Parameter	Symbol	Rating	Units
Collector-Emitter Voltage	V _{CES}	70	V
Emitter-Base Voltage	V _{EBO}	3.0	V
Collector Current (Peak)	I _C	9.0	A
Total Power Dissipation @ +25°C	P _{TOT}	350	W
Storage Temperature	T _{stg}	-65 to +200	°C
Junction Temperature	T _j	200	°C

Electrical Specifications at 25°C

Symbol	Parameter	Test Conditions	Min	Max	Units
BV _{CES}	Collector-Emitter Breakdown Voltage	I _C = 5 mA	70	-	V
I _{CES}	Collector-Emitter Leakage Current	V _{CE} = 32 V	-	10.0	mA
R _{TH(JC)}	Thermal Resistance	V _{CC} = 32V, P _O = 100 W, f = 1100, 1200, 1300 MHz	-	0.5	°C/W
P _{IN}	Input Power	V _{CC} = 32V, P _O = 100 W, f = 1100, 1200, 1300 MHz	-	16	W
G _P	Power Gain	V _{CC} = 32V, P _O = 100 W, f = 1100, 1200, 1300 MHz	8.0	-	dB
η	Collector Efficiency	V _{CC} = 32V, P _O = 100 W, f = 1100, 1200, 1300 MHz	52	-	%
RL	Input Return Loss	V _{CC} = 32V, P _O = 100 W, f = 1100, 1200, 1300 MHz	9	-	dB
VSWR-T	Load Mismatch Tolerance	V _{CC} = 32V, P _O = 100 W, f = 1100, 1200, 1300 MHz	-	3:1	-

V2.00

Test Fixture Electrical Schematic

Top View

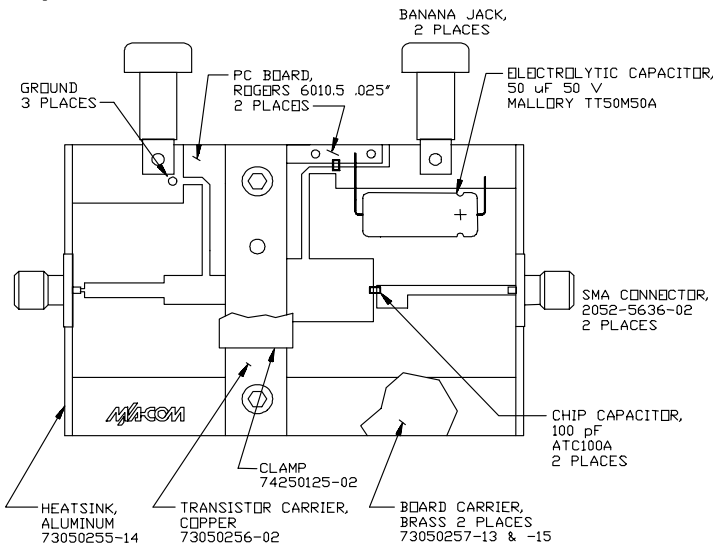

Circuit Dimensions

