

PH85-F1P0S2

850nm High power VCSEL TO-46 Can Package

Features

- : 10mW High power VCSEL
- : 1Gbps data rates
- : 850nm wavelength range
- : Flat window Type TO-46 Can Package
- : Other configurations available on request

Applications

- : High speed Data Communications
- : Gigabit Ethernet
- : Fiber Channel
- : Free Space Optics
- : Sensor

Description



Absolute Maximum Ratings

Parameter	Rating
Storage Temperature	-40 to 100 °C
Operating Temperature	0 to 70 °C
Lead Solder Temperature	260 °C, 10 sec
Continuous Forward Current	30mA
Continuous Reverse Voltage	5V (@10µA)

PH85-F1P0S2

850nm High power VCSEL TO-46 Can Package

Dimensions

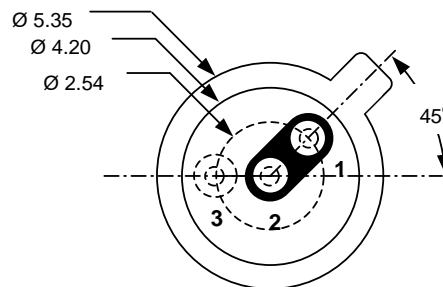
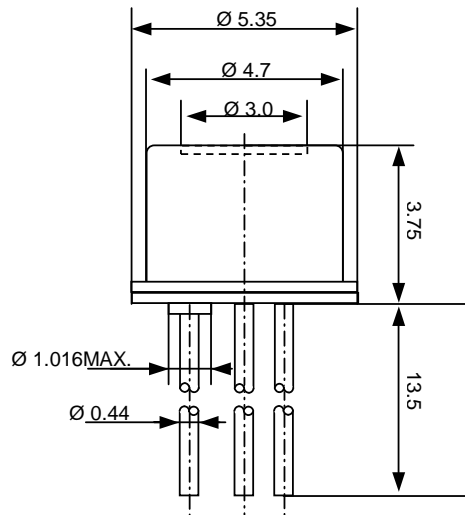

Bottom view

PINOUT

Number	Function
1	A_{LD}
2	K_{LD}
3	NC

Unit:mm

Electro-Optics Characteristics ($T_a=25^{\circ}\text{C}$ unless otherwise stated)

Parameters	Symbol	Specified			Unit	Test Conditions
		Min.	Typ.	Max.		
Threshold Current	I_{th}		5		mA	CW
I_{th} Temperature Variation	ΔI_{th}		2.5		mA	$T_a=0$ to 70°C
Slope Efficiency	η	0.2	0.4		W/A	$I_f = 20\text{mA}$
η Temperature Coefficient	$\Delta\eta / \Delta T$		-0.5		%/ $^{\circ}\text{C}$	$T_a=0$ to 70°C at 20mA
Optical Output Power	P_o		10		mW	$I_f = 20\text{mA}$
Peak Wavelength	λ	840	850	860	nm	$I_f = 20\text{mA}$
λ_P Temperature Coefficient	$\Delta\lambda / \Delta T$		0.06			$T_a=0$ to 70°C at 20mA
Spectral Bandwidth (RMS)	$\Delta\lambda$			0.85	nm	$I_f = 20\text{mA}$
Forward Voltage	V_f	1.6	1.9	2.2	V	$I_f = 20\text{mA}$
Breakdown Voltage	V_b		-10		V	
Dynamic Resistance	R_d		25	40	Ohm	$I_f = 20\text{mA}$

Notes

* These specifications are subject to change without notice

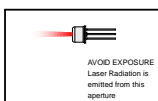
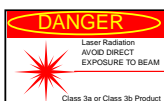

NOTICE

The inherent design of this component causes it to be sensitive to electrostatic discharge(ESD). To prevent ESD-induced damage and/or degradation to equipment, take normal ESD precautions when handling this product

DANGER

The VCSEL is a class IIIb laser and should be treated as a potential eye hazard. Due to the size of the component, the applicable warning logotype, aperture label, and certification / identification label cannot be placed on the component itself.

PH85-F1P0S2

850nm High power VCSEL TO-46 Can Package

