

## Wirewound Rheostat/Potentiometer



### FEATURES

- 25 Watt at 25°C - RT style
- 18 Watt at 25°C - RTE style
- CCTU 05-03B (PA1)
- Vitreous - RT style
- Laquered - RTE style

### DIMENSIONS in millimeters

#### ADAPTATION BOARD

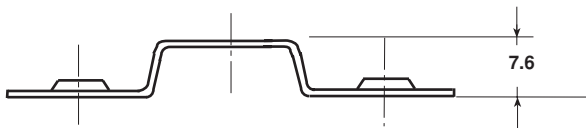
**RT25-PA1**

#### PANEL CUT OUT DETAILS

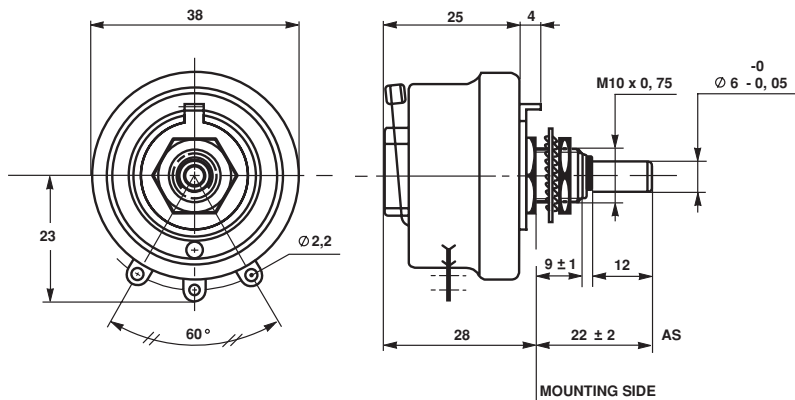
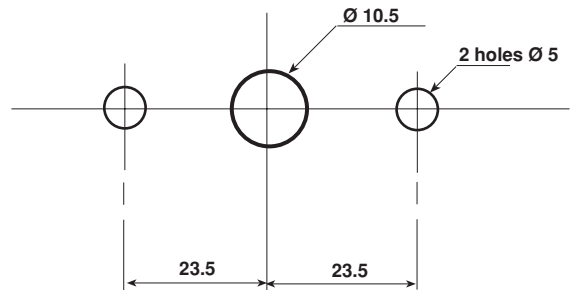

#### PANEL CUT OUT DETAILS

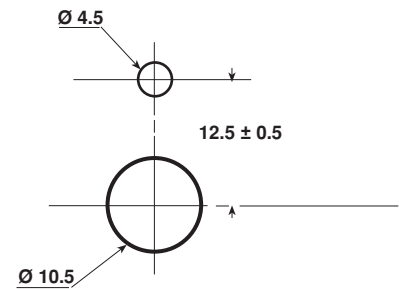

### MECHANICAL SPECIFICATIONS

<b>Mechanical Protection</b>	RT25 vitreous RTE25 lacquered
<b>Mechanical Travel</b>	300° ± 5°
<b>Operating Torque</b>	1 to 10 Ncm
<b>End Stop Torque</b>	50 Ncm
<b>Unit Weight</b>	80 g

### ENVIRONMENTAL SPECIFICATIONS

<b>Temperature Range</b>	RT25 – 55°C + 320°C RTE25 – 55°C + 220°C
<b>Climatic Category</b>	CCTU 454 CEI 55/200/56

### ELECTRICAL SPECIFICATIONS

Ohmic Range	RT25	1Ω to 4.7kΩ
	RTE25	> 5kΩ to 13.5kΩ
<b>Tolerance Standard</b>		± 10%
<b>Power Rating</b>	RT25	25 W at 25°C
	RTE25	18 W at 25°C
<b>Variation Law</b>	Standard	linear
	On request	sectorial winding
<b>Dielectric Strength</b>		1000VRMS
<b>Insulation Resistance</b>		10 <sup>3</sup> MΩ(500Vcc)

### LOCKING DEVICE

This is supplied as an option.

The available spindle length is according to the panel thickness.

Order reference : DBA6.

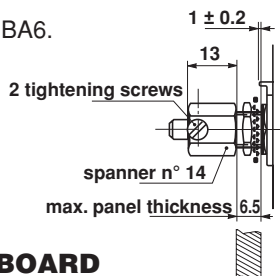

### ADAPTATION BOARD

This enables 2 point mounting instead of bush mounting. The adaptation board is supplied as an option with 2 mounting screws. Consequently, the available spindle length is reduced by 9.5mm.

SPINDLES			
Ø mm	DISTANCE TO MOUNTING PLATE mm	SCREW DRIVER SLOT	CODE
6	22	WITH	ASF
	25	WITHOUT	AM
		WITH	AMF
6	50	WITHOUT	AL
6	22	WITHOUT	AS

For any special requirement on request : spindle flats, etc. Please supply detailed drawing.

PARTICULAR CHARACTERISTICS		
NOMINAL RESISTANCE Ω	MAX. SERVICE VOLTAGE V	MAX. CURRENT THROUGH WIPER mA
1	5	5000
1.5	6.12	4080
2.2	7.42	3370
3.3	9.08	2750
4.7	10.8	2300
6.8	13	1920
10	15.8	1580
15	19.4	1290
22	23.5	1070
33	28.7	870
47	34.3	730
68	41.2	605
100	50	500
150	61.2	408
220	74.2	337
330	90.8	275
470	108	230
680	130	192
1k	158	158
1.5k	194	129
2.2k	235	107
3.3k	287	87
4.7k	343	73

### COMMAND SHAFT 29JF (OPTION)

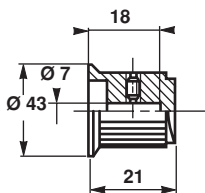

### DIAL CG57 (OPTION)

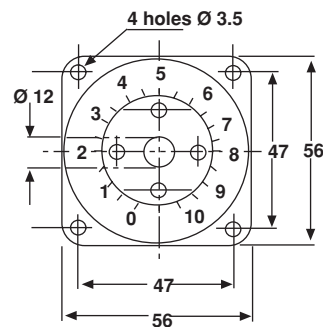

### MARKING

SFERNICE trademark, series, style, power rating in watts, ohmic value (in Ω or kΩ), tolerance (in %), maximum current in A, manufacturing date

ORDERING PROCEDURE									
VITREOUS LACQUERED	RT RTE	25		L			ASF	2.2kΩ	± 10%
	SERIES	STYLE	SPINDLE LOCKING DEVICE	VARIATION LAW	SPECIAL DESIGN	WINDING	SPINDLE (Code)	OHMIC VALUE	TOLERANCE
			Optional		Method N° Optional	Optional	for special spindles please supply detailed drawing		
OPTIONS	ACC MODEL	29JF KNOB	CG57 DIAL	XXX OTHER SPECIAL REQUIREMENTS					