

Wirewound Rheostat/Potentiometer



FEATURES

- 100 Watt at 25°C
- 70 Watt at 25°C
- CCTU 05-03B (PA5)
- Vitreous style RT100
- Lacquered style RTE100

DIMENSIONS in millimeters

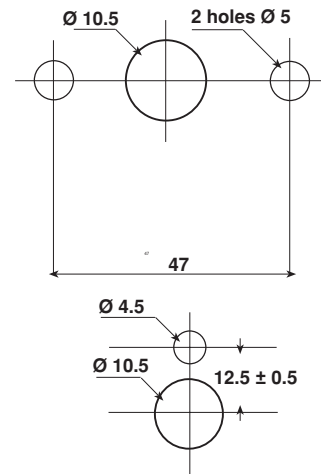
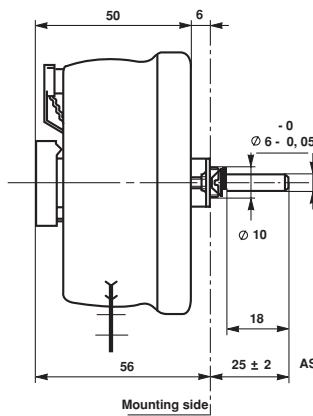
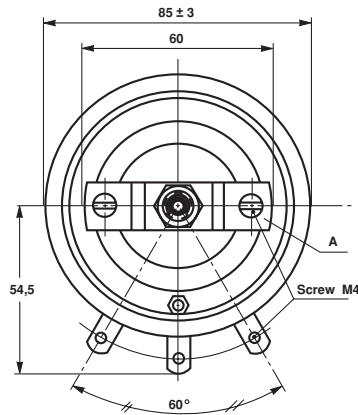
RT100-PA5
PANEL CUT OUT DETAILS

MECHANICAL SPECIFICATIONS

Mechanical Protection	RT100 vitreous RTE100 lacquered
Mechanical Travel	300° ± 5°
Operating Torque	4 to 20 Ncm
End Stop Torque	100 Ncm
Unit Weight	400 g

ENVIRONMENTAL SPECIFICATIONS

Temperature Range	RT100 – 55°C + 320°C RTE100 – 55°C + 220°C
Climatic Category	CCTU 454 CEI 55/200/56

ELECTRICAL SPECIFICATIONS

Parameter	RT100	RTE100
Ohmic Range	1Ω to 15kΩ	> 15kΩ to 54kΩ
Tolerance Standard	± 10%	
Power Rating	100 W at 25°C	70 W at 25°C
Variation Law	Standard	linear
	On request	sectorial winding
Limiting Element Voltage	RT100	850V
	RTE100	800V
Dielectric Strength	1500VRMS	
Insulation Resistance	10 ³ MΩ(500Vcc)	

LOCKING DEVICE

Supplied as an option the spindle locking device can only be fitted to units with control mounting and locating peg.

The part A is removed (see drawing).

The available spindle length is according to the panel thickness.

Order reference : DBA6.

PANEL CUT OUT DETAILS

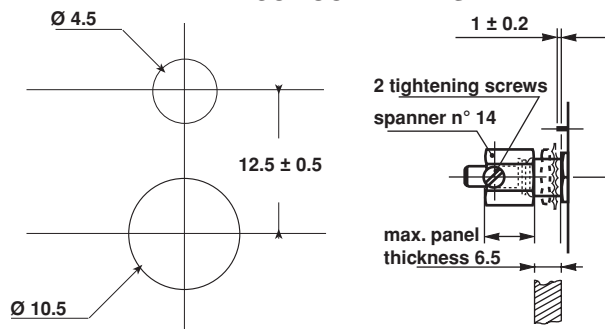

SPINDLES			
Ø mm	DISTANCE TO MOUNTING PLATE mm	SCREW DRIVER SLOT	CODE
6	22	WITHOUT	AD
		WITH	ADF
	25	WITH	ASF
6	50	WITHOUT	AL
	25	WITHOUT	AS

For any special requirement on request : spindle flats, etc. Please supply detailed drawing.

COMMAND KNOB 41JF (OPTION)

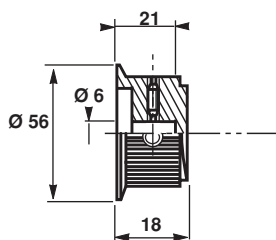

MARKING

SFERNICE trademark, series, style, ohmic value (in Ω or kΩ), tolerance (in %), maximum current in A, manufacturing date

ORDERING PROCEDURE

VITREOUS LACQUERED	RT RTE	100		L			AL	6.8kΩ	± 10%
	SERIES	STYLE	SPINDLE LOCKING DEVICE	VARIATION LAW	SPECIAL DESIGN	WINDING	SPINDLE (Code)	OHMIC VALUE	TOLERANCE
			Optional		Method N° Optional	Optional	for special spindles please supply detailed drawing		
OPTIONS	ACC MODEL	41JF KNOB	CG78 DIAL	XXX OTHER SPECIAL REQUIREMENTS					

PARTICULAR CHARACTERISTICS

NOMINAL RESISTANCE Ω	MAX. SERVICE VOLTAGE V	MAX. CURRENT THROUGH WIPER A
1	10	10
15	12.2	8.16
2.2	14.8	6.74
3.3	18.2	5.50
4.7	21.7	4.61
6.8	26.1	3.84
10	31.6	3.16
15	38.7	2.58
22	46.9	2.13
33	57.4	1.74
47	68.6	1.46
68	82.5	1.2
100	100	1
150	122	0.816
220	148	0.674
330	182	0.550
470	217	0.461
680	261	0.384
1k	316	0.316
1.5k	387	0.258
2.2k	469	0.213
3.3k	574	0.174
4.7k	686	0.146
6.8k	825	0.121
10k	850	0.085
15k	850	0.057

DIAL CG78 (OPTION)

