

AHDG, S,) B

Point Source LED

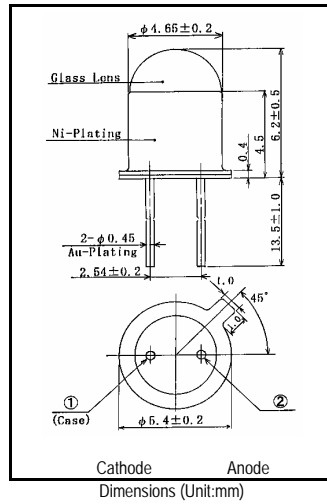

- FEATURES**
- High-output Power
 - Parallel Rays (Super Excellent)
 - Point-source LED
 - Small Temp. Coefficient of PO
- APPLICATIONS**
- Optical Switches
 - Linear & Rotary Encoder

2. ELECTRICAL & OPTICAL CHARACTERISTICS (Ta=25)

ITEM	SYMBOL	CONDITIONS	MIN	TYP	MAX	UNIT
Power Output	PO	IF=50mA	1.8	3.2		mW
Forward Voltage	VF	IF=50mA		1.7	2.2	V
Reverse Current	IR	VR=5V			100	μA
Peak Wavelength	λp	IF=50mA		855		nm
Spectral Line Half Width		IF=50mA		30		nm
Half Intensity Beam Angle		IF=50mA		± 8		deg.

1. ABSOLUTE MAXIMUM RATINGS (Ta=25)

ITEM	SYMBOL	RATINGS	UNIT
Forward Current (DC)	IF	100	mA
Forward Current (Pulse)*1	IFP	0.8	A
Reverse Voltage	VR	5	V
Power Dissipation	PD	190	mW
Operating Temp.	Topr	-30 TO 100	
Storage Temp.	Tstg	-40 TO 125	

*1:Tw=10uS,T=10mS

*2:Time 5 Sec max,Position:Up to 3mm from the body

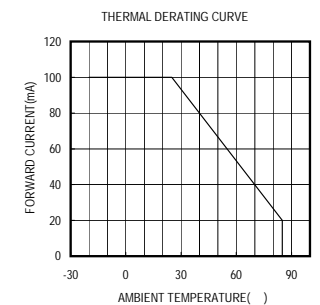
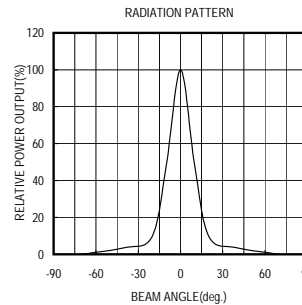
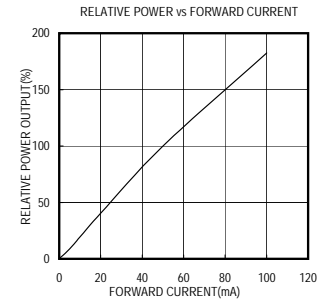
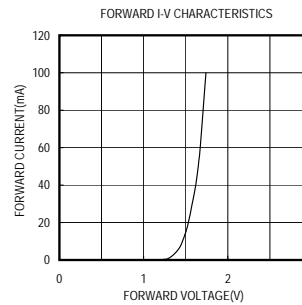
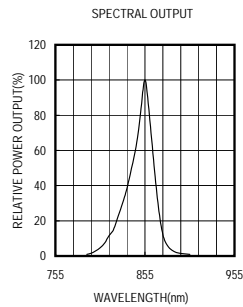

To purchase this part contact
Marktech Optoelectronics at
800.984.5337

Marktech
Optoelectronics
www.marktechopto.com

