

Features

- Single power supply voltage of 1.65V to 1.95V
- Power down features using CE1# and CE2
- Low power dissipation
- Data retention supply voltage: 0.9V to 1.95V
- Direct TTL compatibility for all input and output
- Wide operating temperature range: -40°C to 85°C
- Standby current @ VDD = 1.95 V

	I _{SB}
	Maximum
EM584161BA/BC-70/85	8 μA
EM584161BA-70E/85E	80 μA

Ordering Information

Part Number	Speed	I _{SB}	Package
EM584161BC-70	70 ns	8 μA	6x8 BGA
EM584161BA-70	70 ns	8 μA	8x10 BGA
EM584161BA-70E	70 ns	80 μA	8x10 BGA
EM584161BC-85	85 ns	8 μA	6x8 BGA
EM584161BA-85	85 ns	8 μA	8x10 BGA
EM584161BA-85E	85 ns	80 μA	8x10 BGA

Overview

The EM584161 is a 4,194,304-bit SRAM organized as 262,144 words by 16 bits. It is designed with advanced CMOS technology. This Device operates from a single 1.65V to 1.95V power supply. Advanced circuit technology provides both high speed and low power. It is automatically placed in low-power mode when chip enable (CE1#) is asserted high or (CE2) is asserted low. There are three control inputs. CE1# and CE2 are used to select the device and for data retention control, and output enable (OE#) provides fast memory access. Data byte control pin (LB#,UB#) provides lower and upper byte access. This device is well suited to various microprocessor system applications where high speed, low power and battery backup are required. And, with a guaranteed operating range from -40°C to 85°C, the EM584161 can be used in environments exhibiting extreme temperature conditions.

Etron Technology, Inc.

No. 6, Technology Rd. V, Science-Based Industrial Park, Hsinchu, Taiwan 30077, R.O.C.
 TEL: (886)-3-5782345 FAX: (886)-3-5778671

Pin Configuration

48-Ball BGA (CSP), Top View

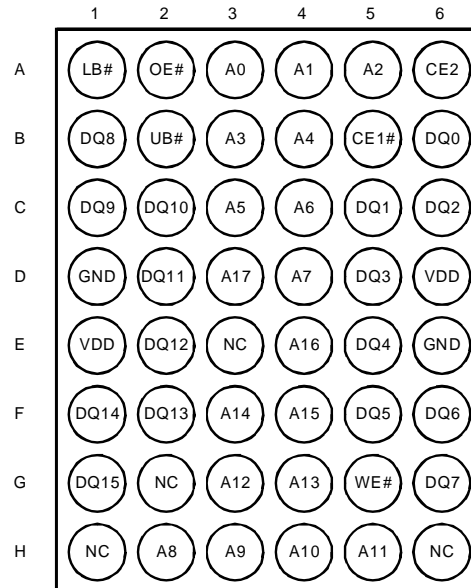

Pin Description

Symbol	Function
A0 - A17	Address Inputs
DQ0 - DQ15	Data Inputs / Outputs
CE1#, CE2	Chip Enable Inputs
OE#	Output Enable
WE#	Read / Write Control Input
LB#, UB#	Data Byte Control Inputs
GND	Ground
VDD	Power Supply
NC	No Connection

Block Diagram

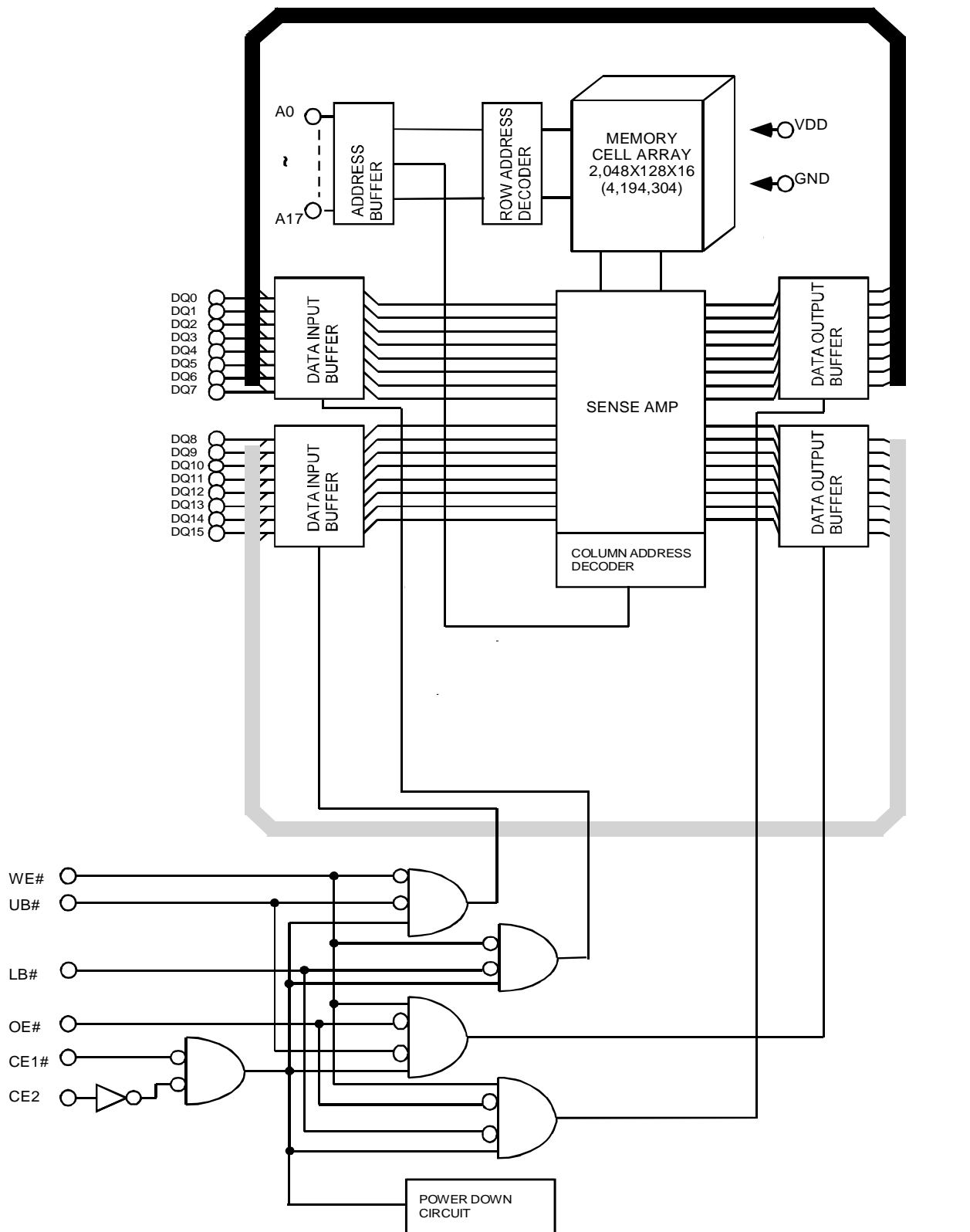

Operating Mode

Mode	CE1#	CE2	OE#	WE#	LB#	UB#	DQ0~DQ7	DQ8~DQ15
Read	L	H	L	H	L	L	D _{OUT}	D _{OUT}
					H	L	High-Z	D _{OUT}
					L	H	D _{OUT}	High-Z
Write	L	H	X	L	L	L	D _{IN}	D _{IN}
					H	L	High-Z	D _{IN}
					L	H	D _{IN}	High-Z
Output Deselect	L	H	H	H	X	X	High-Z	High-Z
	L	H	X	X	H	H		
Standby	H	X	X	X	X	X	High-Z	High-Z
	X	L	X	X	X	X		

Note: X = don't care. H=logic high. L=logic low.

Absolute Maximum Ratings

Supply voltage, V _{DD}	-0.5 to +2.5V
Input voltages, V _{IN}	-0.5 to +2.5V
Input and output voltages, V _{I/O}	-0.5 to V _{DD} +0.5V
Operating temperature, T _{OPR}	-40 to +85°C
Storage temperature, T _{STRG}	-65 to +150°C
Soldering Temperature (10s), T _{SOLDER}	240°C
Power dissipation, P _D	0.6 W

DC Recommended Operating Conditions (Ta=-40°C to 85°C)

Symbol	Parameter	Min.	Typ.	Max.	Unit
V _{DD}	Power Supply Voltage	1.65	1.8	1.95	V
V _{IH}	Input High Voltage	1.4	–	V _{DD} +0.2 ⁽¹⁾	V
V _{IL}	Input Low Voltage	-0.2 ⁽²⁾	–	0.4	V
V _{DR}	Data Retention Supply Voltage	0.9	–	1.95	V

Note:

(1) Overshoot : 2.7V if pulse width ≤ 20ns

(2) Undershoot : -1.0V if pulse width ≤ 20ns

DC Characteristics (Ta = -40°C to 85°C, V_{DD} = 1.65V to 1.95V)

Symbol	Parameter	Test Conditions	Min.	Typ.	Max.	Unit
I _{DD1}	Operating current @ min cycle time	CE1# = V _{IL} and CE2 = V _{IH} and I _{OUT} = 0mA	-	-	15	mA
I _{DD2}	Operating current @ max cycle time (1μs)	Other Input = V _{IH} / V _{IL}	-	-	2	mA
I _{SB}	Standby current	CE1# ≥ V _{DD} - 0.2V, or CE2 ≤ 0.2V, Others inputs ≤ 0.2V or ≥ V _{DD} - 0.2V	-	-	8	μA
V _{OH}	Output HIGH Voltage	I _{OH} = -100 μA	V _{DD} - 0.2V	-	-	V
V _{OL}	Output LOW Voltage	I _{OL} = 100 μA	-	-	0.3	V

Notes:

* Typical value are measured at Ta = 25°C.

** In standby mode with CE1# ≥ V_{DD} - 0.2V, these limits are assured for the condition CE2 ≥ V_{DD} - 0.2V or CE2 ≤ 0.2V.

Capacitance (Ta = 25°C; f = 1 MHz)

Parameter	Symbol	Min	Typ	Max	Unit	Test Conditions
Input capacitance	C _{IN}	-	-	10	pF	V _{IN} = GND
Output capacitance	C _{OUT}	-	-	10	pF	V _{OUT} = GND

Notes: This parameter is periodically sampled and is not 100% tested.

AC Characteristics and Operating Conditions(Ta = -40°C to 85°C, V_{DD} = 1.65V to 1.95V)

Read Cycle						
Symbol	Parameter	EM584161				Unit
		-85		-70		
		Min	Max	Min	Max	
t _{RC}	Read cycle time	85	-	70	-	ns
t _{AA}	Address access time	-	85	-	70	
t _{CO1}	Chip Enable (CE1#) Access Time	-	85	-	70	
t _{CO2}	Chip Enable (CE2) Access Time	-	85	-	70	
t _{OE}	Output enable access time	-	45	-	35	
t _{BA}	Data Byte Control Access Time	-	45	-	35	
t _{LZ}	Chip Enable Low to Output in Low-Z	10	-	10	-	
t _{OLZ}	Output enable Low to Output in Low-Z	3	-	3	-	
t _{BLZ}	Data Byte Control Low to Output in Low-Z	5	-	5	-	
t _{HZ}	Chip Enable High to Output in High-Z	-	35	-	25	
t _{OHZ}	Output Enable High to Output in High-Z	-	35	-	25	
t _{BHZ}	Data Byte Control High to Output in High-Z	-	35	-	25	
t _{OH}	Output Data Hold Time	10	-	10	-	
Write Cycle						
Symbol	Parameter	EM584161				Unit
		-85		-70		
		Min	Max	Min	Max	
t _{WC}	Write cycle time	85	-	70	-	ns
t _{WP}	Write pulse width	55	-	55	-	
t _{CW}	Chip Enable to end of write	70	-	60	-	
t _{BW}	Data Byte Control to end of Write	70	-	60	-	
t _{AS}	Address setup time	0	-	0	-	
t _{WR}	Write Recovery time	0	-	0	-	
t _{WHZ}	WE# Low to Output in High-Z	-	35	-	30	
t _{OW}	WE# High to Output in Low-Z	5	-	5	-	
t _{DS}	Data Setup Time	35	-	30	-	
t _{DH}	Data Hold Time	0	-	0	-	

AC Test Condition

- Output load : 30pF + one TTL gate
- Input pulse level : 0.2V, V_{DD}-0.2V
- Timing measurements : 0.5 x V_{DD}
- t_R, t_F : 5ns

Read Cycle (See Note 1)

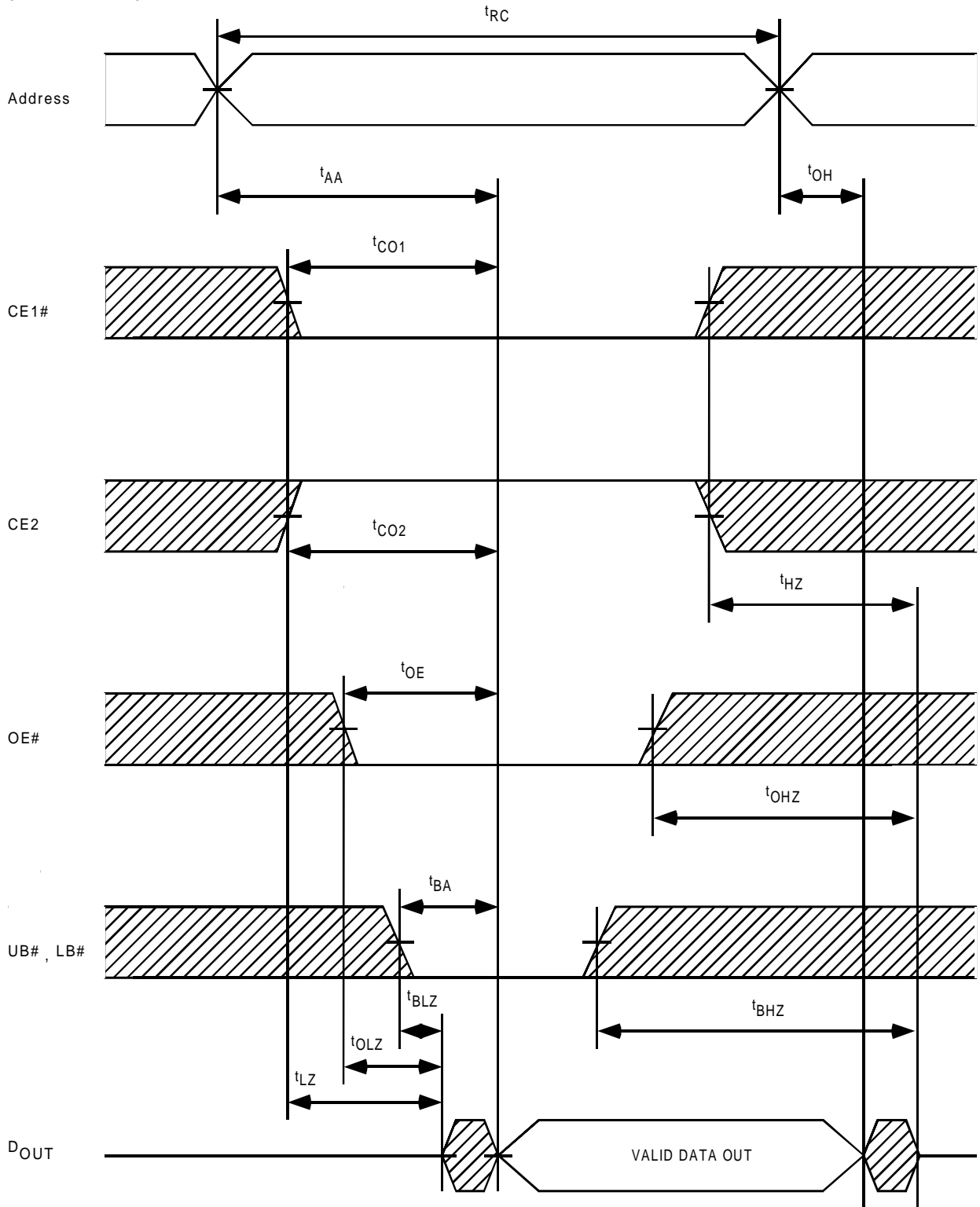

Write Cycle1 (WE# Controlled)(See Note 4)

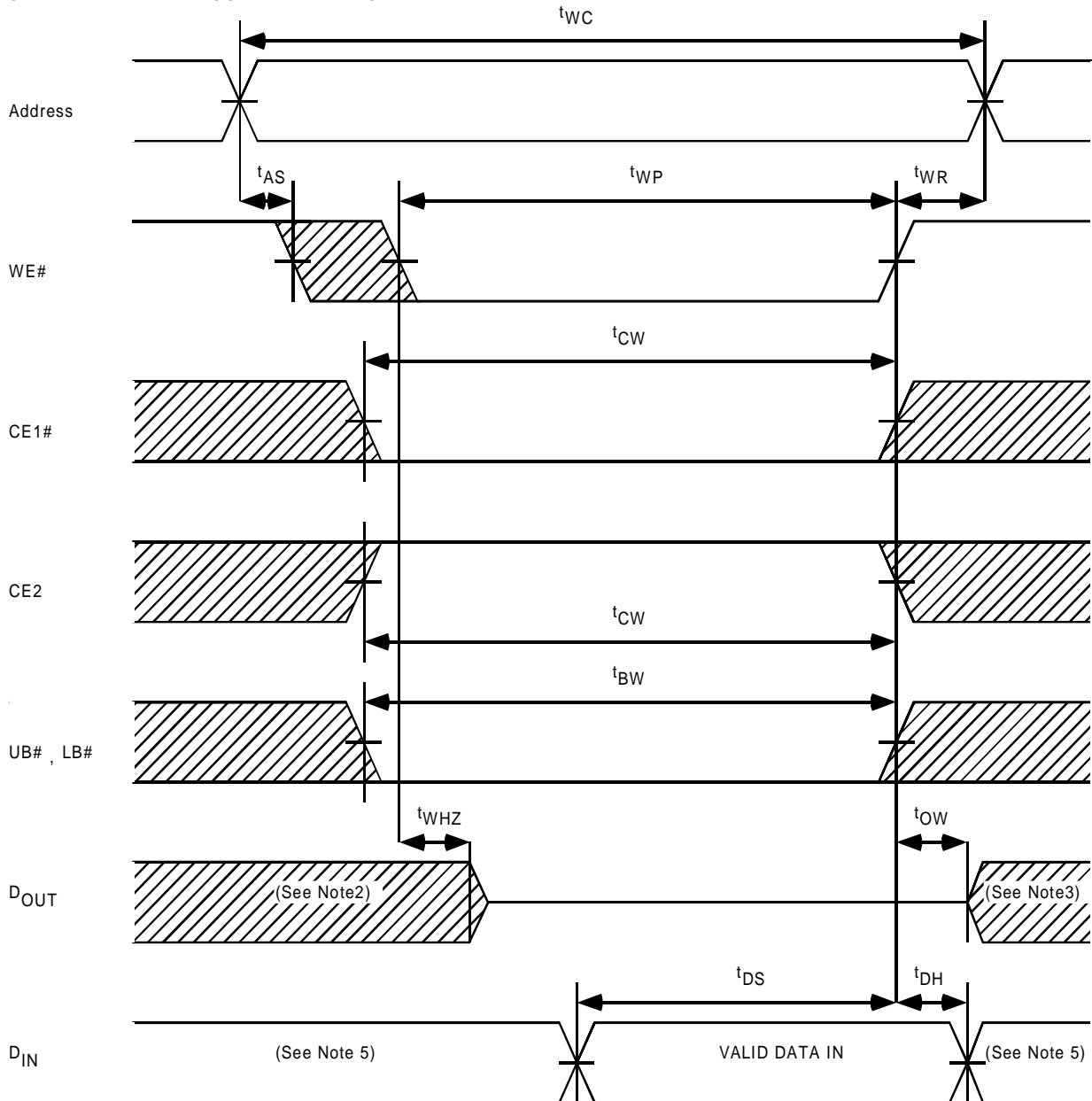

Write Cycle 2 (CE1# Controlled)(See Note 4)

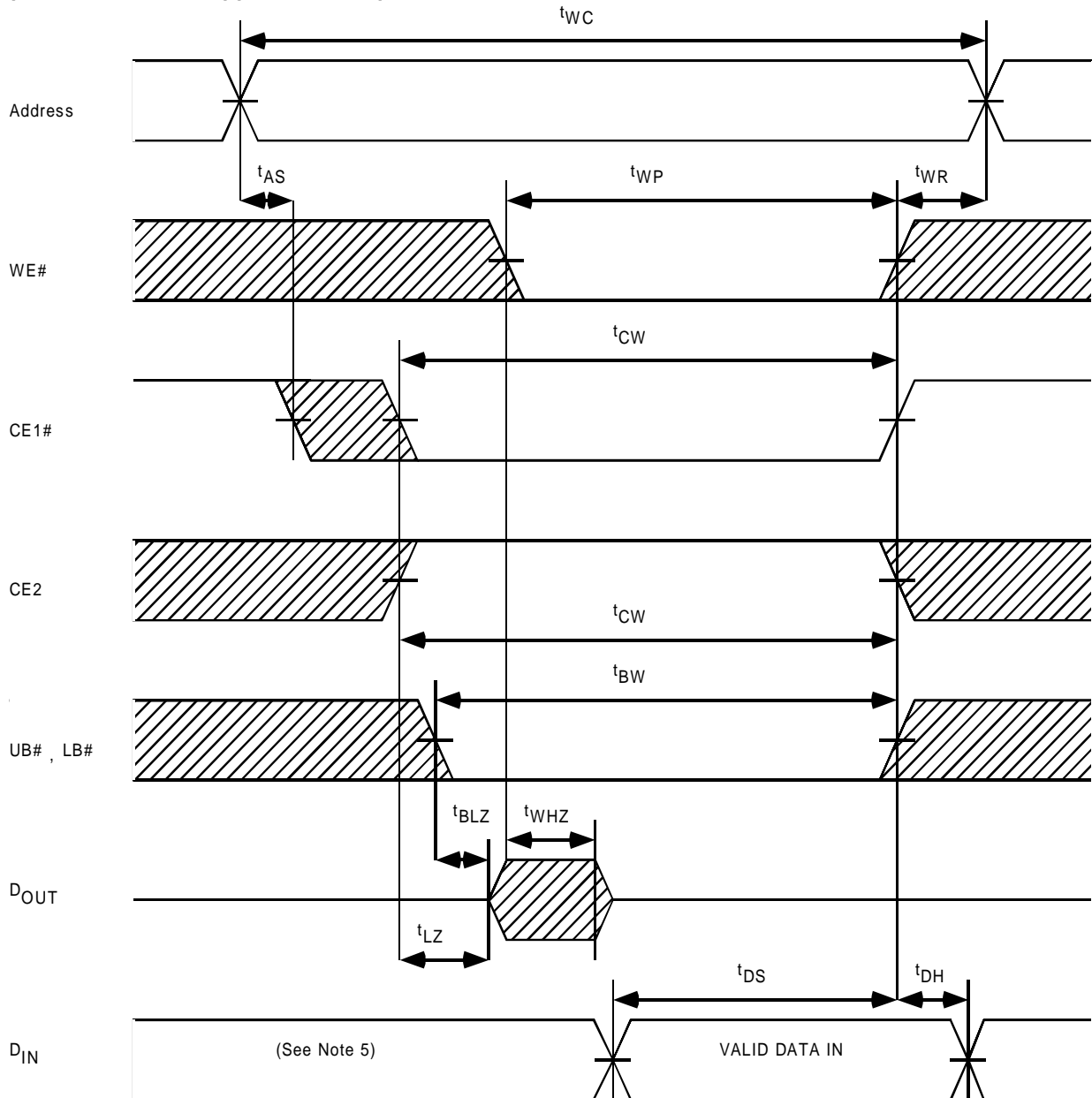

Write Cycle 3 (CE2 Controlled)(See Note 4)

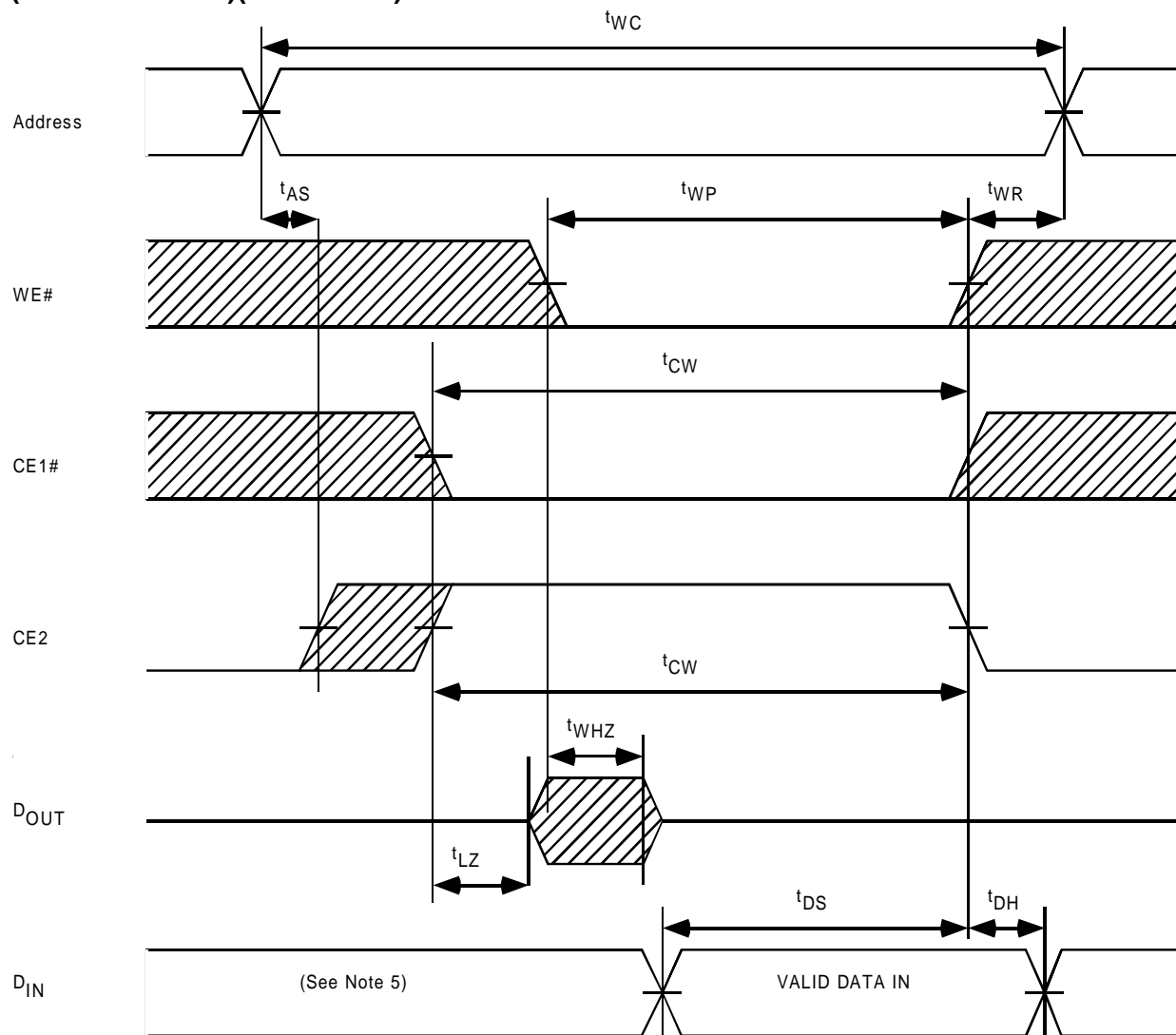

Write Cycle4 (UB#, LB# Controlled)(See Note 4)

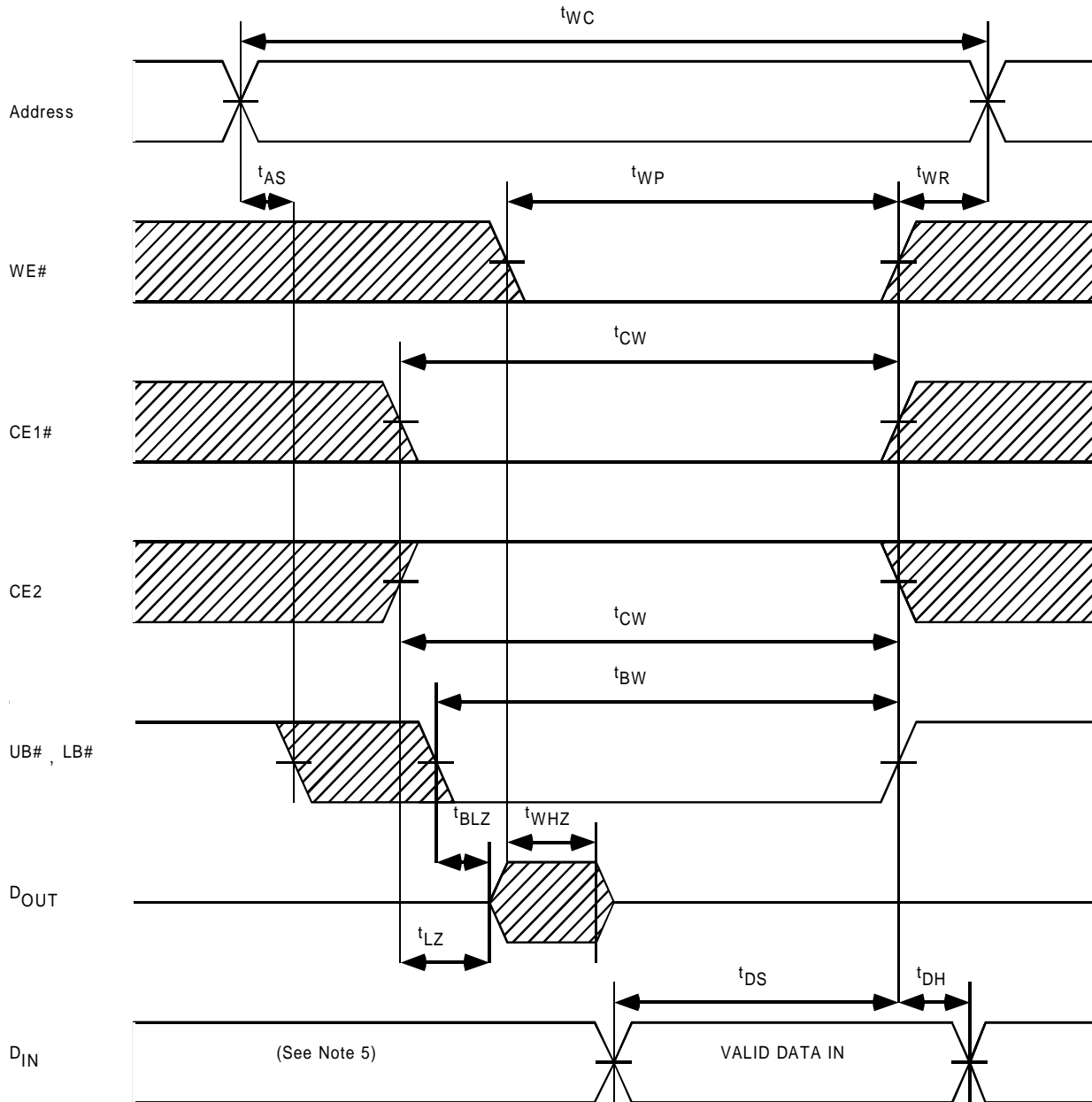

Note:

1. WE# remains HIGH for the read cycle.
2. If CE1# goes LOW (or CE2 goes HIGH) with or after WE# goes LOW, the outputs will remain at high impedance.
3. If CE1# goes HIGH (or CE2 goes LOW) coincident with or before WE# goes HIGH, the outputs will remain at high impedance.
4. If OE# is HIGH during the write cycle, the outputs will remain at high impedance.
5. Because I/O signals may be in the output state at this time, input signals of reverse polarity must not be applied.

Data Retention Characteristics (Ta = -40°C to 85°C)

Symbol	Parameter		Min	Typ	Max	Unit
V _{DR}	Data Retention Supply Voltage	CE1# ≥ V _{DD} - 0.2V, CE2 ≤ 0.2V, VIN ≥ V _{DD} - 0.2V or VIN ≤ 0.2V	0.9	-	1.95	V
I _{DR}	Data Retention Current	V _{DD} = 0.9V, CE1# ≥ V _{DD} - 0.2V, CE2 ≤ 0.2V, VIN ≥ V _{DD} - 0.2V or VIN ≤ 0.2V	-	-	4.0	μA
t _{SDR}	Chip Deselect to Data Retention Mode Time		0	-	-	ns
t _{RDR}	Recovery Time		t _{RC}	-	-	ns

CE1# Controlled Data Retention Mode

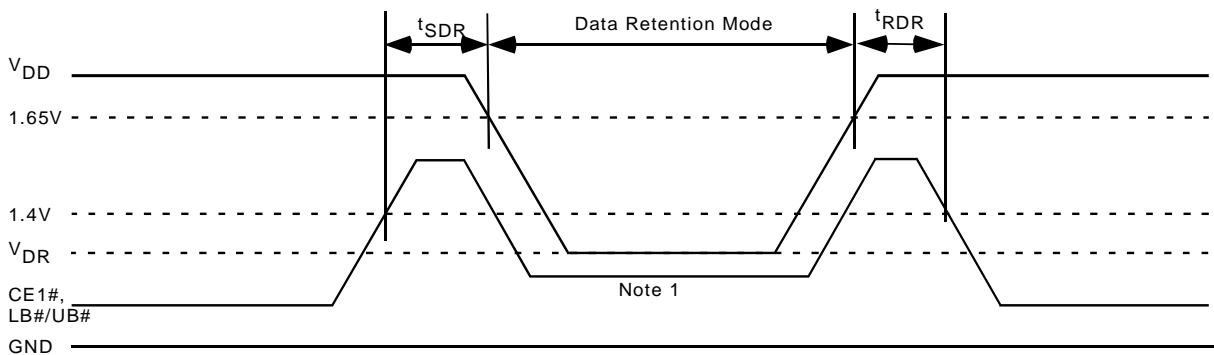

CE2 Controlled Data Retention Mode

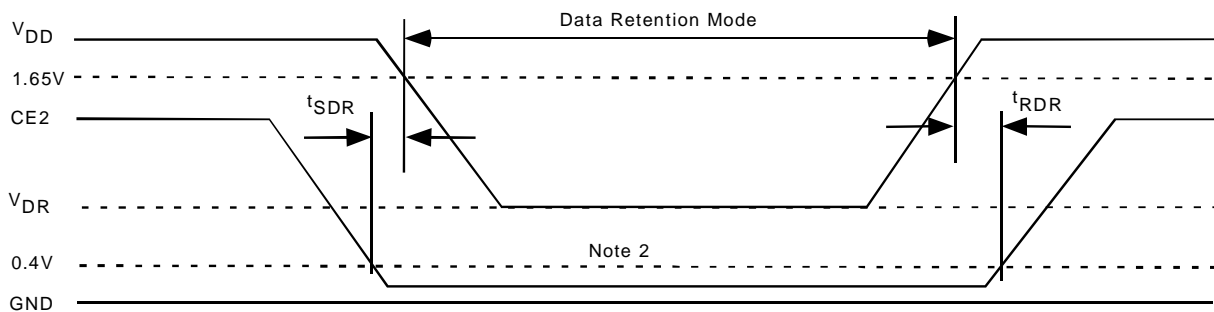

Note:

1. CE1# ≥ V_{DD} - 0.2V or UB# = LB# ≥ V_{DD} - 0.2V
2. CE2 ≤ 0.2V

Package Diagrams

48-Ball (8mm x 10mm) BGA

Units in mm

