



SINGLE PHASE FAST RECOVERY BRIDGE RECTIFIER

FBR605 THRU FBR610

VOLTAGE RANGE
CURRENT

50 to 1000 Volts
6.0 Ampere

FEATURES

- UL recognized
- High forward surge current capability
- High isolation voltage from case to lead
- High temperature soldering guaranteed:
260°C / 10 seconds

MECHANICAL DATA

- Case: Molded plastic body
- Terminal: Lead solderable per MIL-STD-202E method 208C
- Polarity: Polarity symbols marked on case
- Mounting: Thru hole for #6 screw, 5 in-lbs Torque max.
- Weight: 0.13 ounce, 3.66 gram

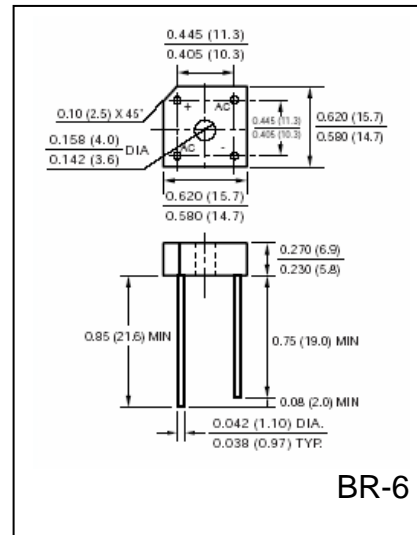

BR-6

MAXIMUM RATINGS AND ELECTRICAL CHARACTERISTICS

- Ratings at 25°C ambient temperature unless otherwise specified
- Single Phase, half wave, 60Hz, resistive or inductive load
- For capacitive load derate current by 20%

	SYMBOLS	FBR 605	FBR 61	FBR 62	FBR 64	FBR 66	FBR 68	FBR 610	UNIT
Maximum Repetitive Peak Reverse Voltage	V_{RRM}	50	100	200	400	600	800	1000	Volts
Maximum RMS Voltage	V_{RMS}	35	70	140	280	420	560	700	Volts
Maximum DC Blocking Voltage	V_{DC}	50	100	200	400	600	800	1000	Volts
Maximum Average Forward Rectified Current,	At $T_C = 50^\circ\text{C}$ (Note 1)	6							Amps
	At $T_A = 25^\circ\text{C}$ (Note 2)	3							
Peak Forward Surge Current 8.3mS single half sine wave superimposed on rated load (JEDEC method)	I_{FSM}	125							Amps
Rating for Fusing ($t < 8.3\text{mS}$)	I^2t	64							A^2s
Maximum Instantaneous Forward Voltage drop per Bridge element 3.0A	V_F	1.2			1.3				Volts
Maximum DC Reverse Current at Rated DC Blocking Voltage per element	I_R	10							μA
$T_A = 25^\circ\text{C}$ $T_A = 100^\circ\text{C}$		1.0							mA
Maximum Reverse Recovery Time Test conditions $I_F = 0.5\text{A}$, $I_R = 1.0\text{A}$, $I_{RR} = 0.25\text{A}$	t_{rr}	150			250	500		nS	
Isolation Voltage from case to lug	V_{ISO}	2500							Volts
Typical Thermal Resistance (Note 1)	$R_{\theta Jc}$	8.0							$^\circ\text{C}/\text{W}$
Operating Junction Temperature	T_J	(-55 to +150)							$^\circ\text{C}$
Storage Temperature Rang	T_{STG}	(-55 to +150)							$^\circ\text{C}$

Notes:

1. Unit mounted on 6" x 5.5" x 0.11" (15cm x 14cm x 0.3cm) AL plate
2. Unit mounted on PC board 0.375" (9.5mm) lead length with 0.47" x 0.47" (12mm x 12mm) copper pads

RATINGS AND CHARACTERISTIC CURVES FBR605 THRU FBR610

FIG.1-DERATING CURVE FOR OUTPUT RECTIFIED CURRENT

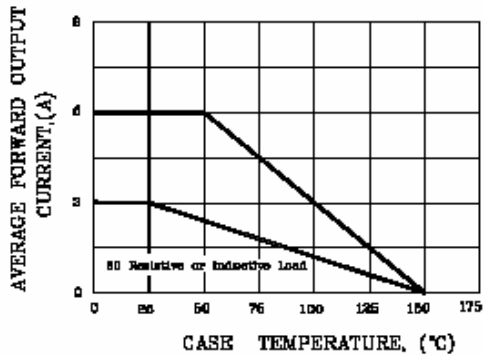

FIG.2-MAXIMUM NON-REPETITIVE PEAK FORWARD SURGE CURRENT

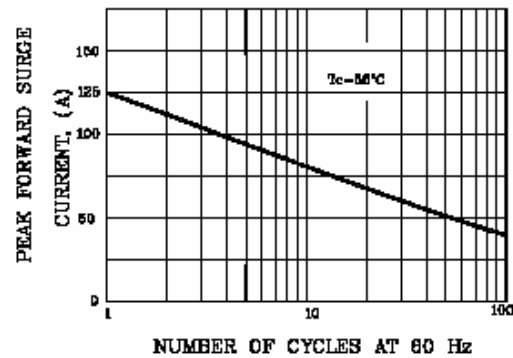

FIG.3-TYPICAL FORWARD CHARACTERISTICS PER DIODE

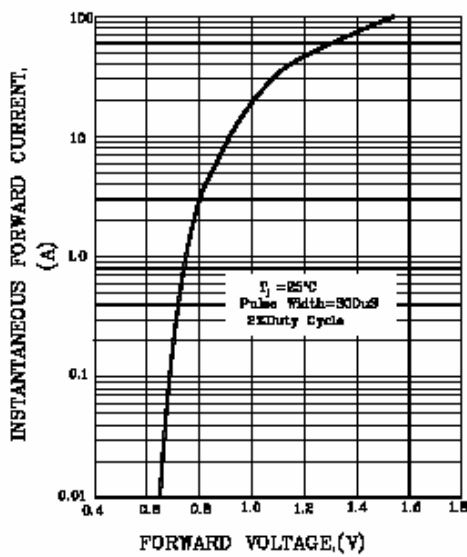

FIG.4-TYPICAL REVERSE CHARACTERISTICS PER DIODE

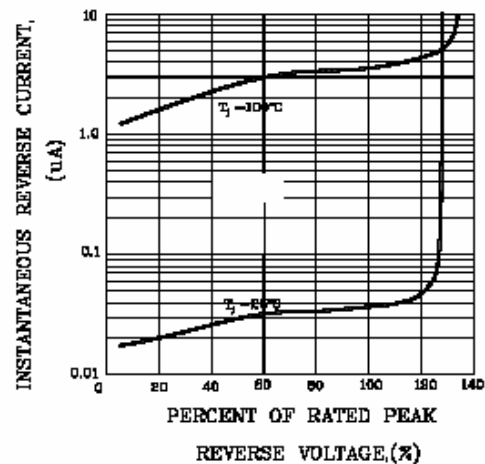
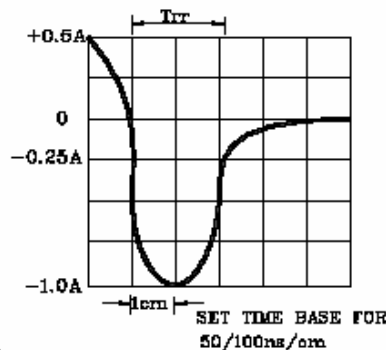
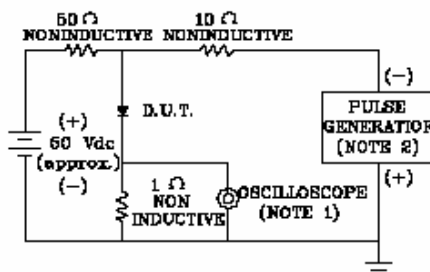

FIG.5-TEST CIRCUIT DIAGRAM AND REVERSE RECOVERY TIME CHARACTERISTIC



- NOTES: 1. Rise Time = 7ns max. Input Impedance = 1 megohm. 22pF
2. Rise time = 10ns max. Source Impedance = 50 ohms