



LIGHTING FOREVER

Surface - Mount RGB Color Sensor

CLS15-22C/L213R/TR8
CLS15-22C/L213G/TR8
CLS15-22C/L213B/TR8

Features

- Surface-mount plastic package
- High sensitivity for Red, Green, and Blue light source
CLS15-22C/L213R/TR8 ($\lambda_p = 620\text{nm}$, Red)
CLS15-22C/L213G/TR8 ($\lambda_p = 550\text{nm}$, Green)
CLS15-22C/L213B/TR8 ($\lambda_p = 470\text{nm}$, Blue)
- Good stable analog output with temperature shift
- Size: 3.2mm (L)*2.7mm (W)*1.1mm (H)
- Operating temperature performance, -40°C to 85°C
- Active area: 1.8 mm^2
- RoHS compliant and Pb free package

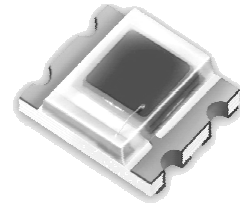

Descriptions

CLS15-22C/L213/TR8 series color sensor device is one channel Si photodiode sensitivity to Red, Green and Blue region spectrum in miniature SMD package. Everlight color sensor series product is the good effective and low cost solution to white color balance, color detection and color management applications.

Applications

- Color adjustment for LED back light system
- Color adjustment for LED projector
- Color detection
- White balance adjustment
- Consumer and mobile appliances

Package Dimensions

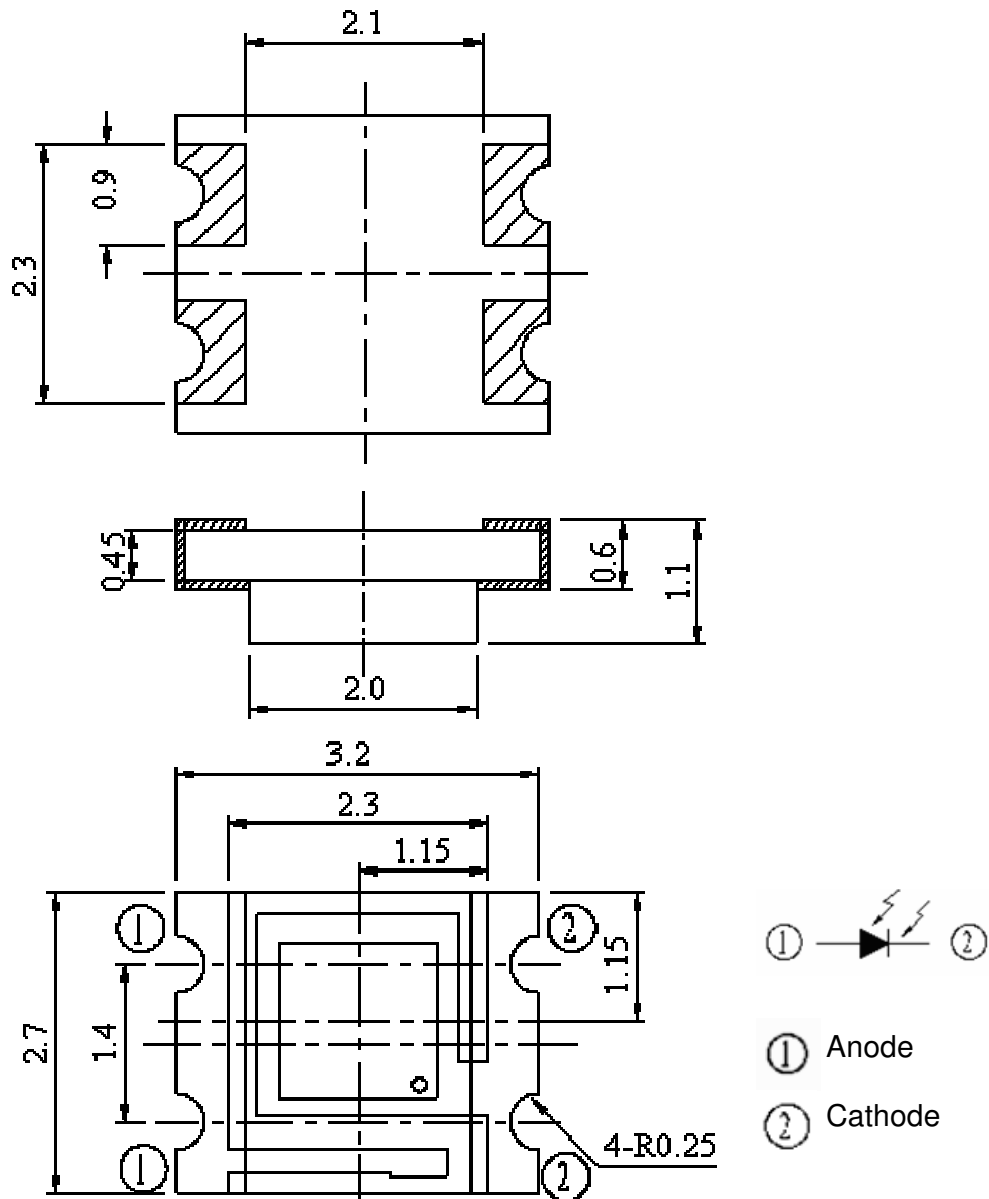

Unit: mm

Tolerances: ± 0.1mm

Absolute Maximum Ratings (Ta=25°C)

Parameter	Symbol	Condition	Rating	Units
Reverse Breakdown Voltage	V_{BR}	$I_R = 100\mu A$	35	V
Forward Voltage	V_F	$I_F = 10mA$	0.5~1.3	V
Operating Temperature	T_{opr}	—	-40 ~ +85	°C
Storage Temperature	T_{stg}	—	-40 ~ +85	°C
Soldering Temperature [Note]	T_{sol}	—	260	°C

Note: Soldering time \leq 5 seconds

Electro-Optical Characteristics (Ta=25°C)

Red Color Sensor: CLS15-22C/L213R/TR8

Parameter	Symbol	Condition	MIN.	TYP.	MAX.	Unit
Peak Sensitivity Wavelength	λ_P	—	—	620	—	nm
Short-Circuit Current	I_{SC}	$E_e=100Lux$ $V_R=0V$ [Note]	—	0.086	—	μA
Reverse Light Current	I_{L1}	$E_e=100Lux$ $V_R=5V$ [Note]	—	0.091	—	μA
	I_{L2}	$E_e=1000Lux$ $V_R=5V$ [Note]	—	0.83	—	μA
Reverse Dark Current	I_D	$E_e=0$ $V_R = 10 V$	—	2	10	nA
Photo sensitivity	S	Red ($\lambda_P=630nm$)	—	0.21	—	A/W

Note: White Fluorescent light (Color Temperature = 6500K) is used as light source

Green Color Sensor: CLS15-22C/L213G/TR8

Parameter	Symbol	Condition	MIN.	TYP.	MAX.	Unit
Peak Sensitivity Wavelength	λ_P	—	—	550	—	nm
Short-Circuit Current	I_{SC}	$E_e=100\text{Lux}$ $V_R=0\text{V}$ [Note]	—	0.075	—	μA
Reverse Light Current	I_{L1}	$E_e=100\text{Lux}$ $V_R=5\text{V}$ [Note]	—	0.082	—	μA
	I_{L2}	$E_e=1000\text{Lux}$ $V_R=5\text{V}$ [Note]	—	0.72	—	μA
Reverse Dark Current	I_D	$E_e=0\text{ Lux}$ $V_R = 10\text{ V}$	—	2	10	nA
Photo sensitivity	S	Green ($\lambda_P=520\text{nm}$)	—	0.18	—	A/W

Note: White Fluorescent light (Color Temperature = 6500K) is used as light source

Blue Color Sensor: CLS15-22C/L213B/TR8

Parameter	Symbol	Condition	MIN.	TYP.	MAX.	Unit
Peak Sensitivity Wavelength	λ_P	—	—	470	—	nm
Short-Circuit Current	I_{SC}	$E_e=100\text{Lux}$ $V_R=0\text{V}$ [Note]	—	0.042	—	μA
Reverse Light Current	I_{L1}	$E_e = 100\text{Lux}$ $V_R=5\text{V}$ [Note]	—	0.046	—	μA
	I_{L2}	$E_e = 1000\text{Lux}$ $V_R=5\text{V}$ [Note]	—	0.39	—	μA
Reverse Dark Current	I_D	$V_R = 10\text{ V}$	—	2	10	nA
Photo sensitivity	S	Blue ($\lambda_P=465\text{nm}$)	—	0.09	—	A/W

Note: White Fluorescent light (Color Temperature = 6500K) is used as light source

Typical Electro-Optical Characteristics Curves

Fig.1 Dark Current vs. Temperature

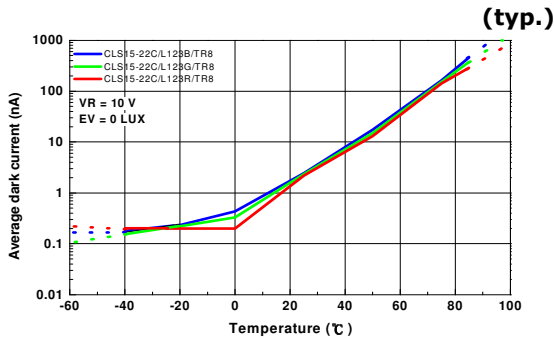

Fig.2 Light current vs. Illuminance

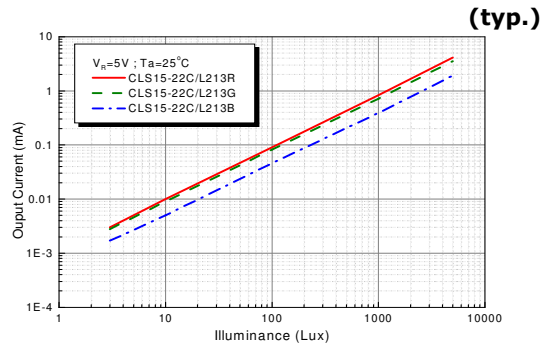

Fig.3 Light current vs. Voltage

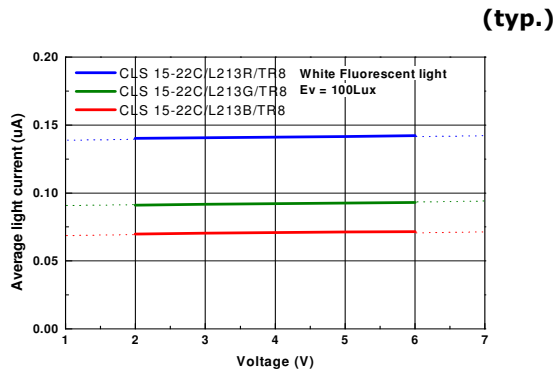

Fig.4 Light current vs. Temperature

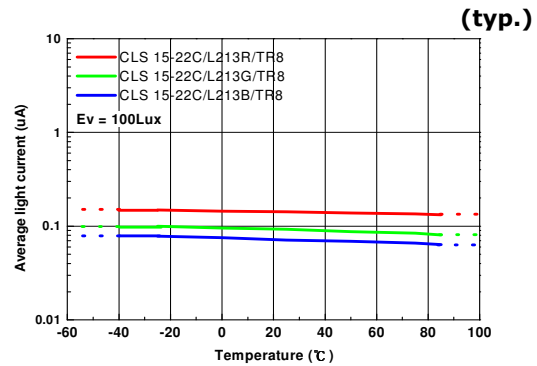

Fig.5 Spectral Response (Blue region)

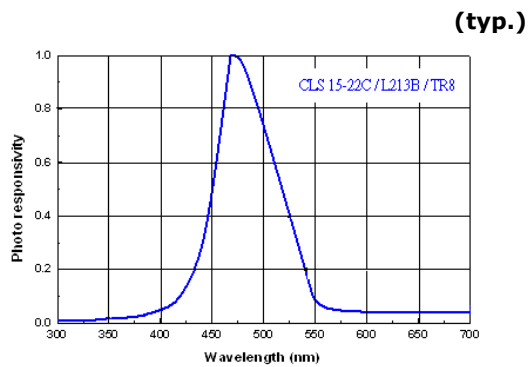
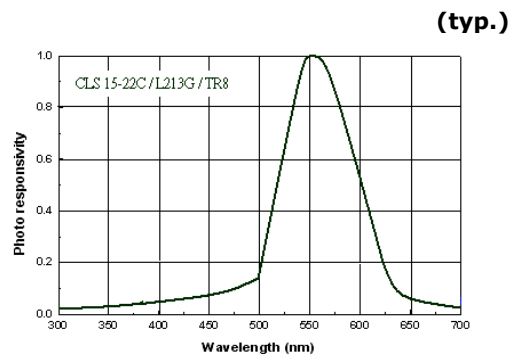

Fig.6 Spectral Response (Green region)





LIGHTING FOREVER

Surface - Mount
RGB Color Sensor

CLS15-22C/L213R/TR8
CLS15-22C/L213G/TR8
CLS15-22C/L213B/TR8

Fig.7 Spectral Response (Red region)

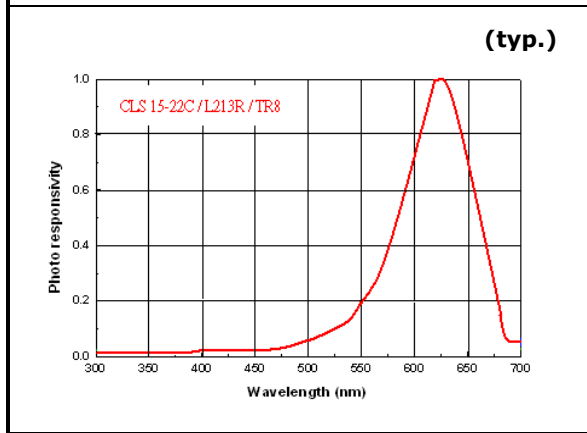

Recommended method of storage

Reflow Terms: JEDEC Level 4 Specification

Dry box storage is recommended as soon as the aluminum bag has been opened prevent moisture absorption. The following conditions should be observed, if dry boxes are not available:

- Storage temperature 10°C to 30°C
- Storage humidity $\leq 60\%RH$ max

After more than 72 hours under these conditions moisture content will be too high for Reflow soldering. In case of moisture absorption, the devices will recover to former condition by drying under the following condition:

192 hours at 40°C+5°C/-0°C and 5%RH (dry air / nitrogen), or
96 hours at 60°C+5°C and < 5%RH for all device containers, or
24 hours at 125°C+5°C not suitable for reel or tubes

ESD Precaution:

Proper storage and handing procedures should be followed to prevent ESD damage to the devices especially when they are removed from the Anti-static bag. Electro-Static Sensitive Devices warning labels are on the packing.

Recommended Solder Profile

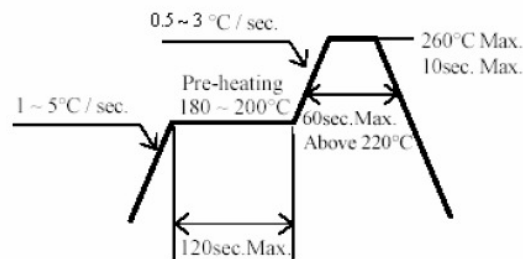

Notice:

- (1) Reflow soldering should not be done more than two times.
- (2) When soldering, do not put stress on the devices during heating.
- (3) After soldering, do not warp the circuit board.

Soldering Iron

Each terminal is to go to the tip of soldering iron temperature less than 350°C for 3 seconds within once in less than the soldering iron capacity 25W. Leave two seconds and more intervals, and do soldering of each terminal. Be careful because the damage of the product is often started at the time of the hand solder.

Repairing

Repair should not be done after the device have been soldered. When repairing is unavoidable, a double-head soldering iron should be used (as below figure). It should be confirmed beforehand whether the characteristics of the device will or will not be damaged by repairing.

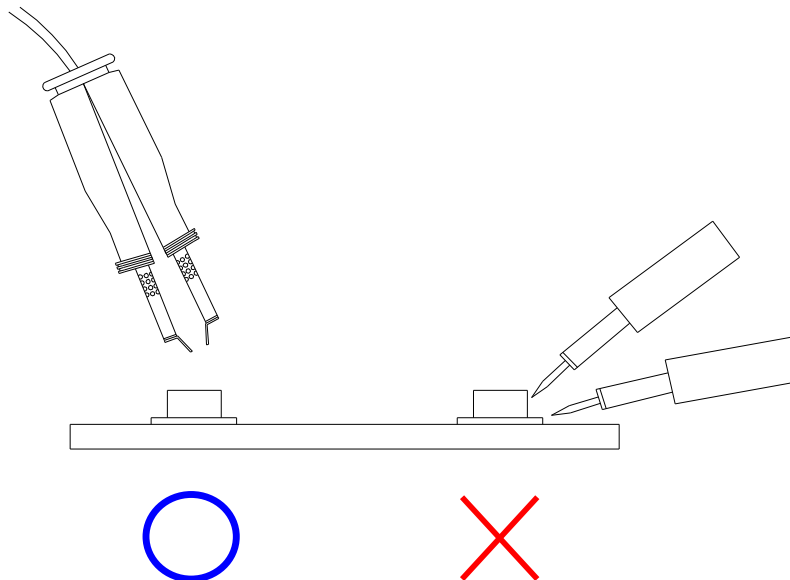



LIGHTING FOREVER

Surface - Mount
RGB Color Sensor

CLS15-22C/L213R/TR8
CLS15-22C/L213G/TR8
CLS15-22C/L213B/TR8

Packing Quantity Specification

2000 PCS/ 1 Reel

Label Format

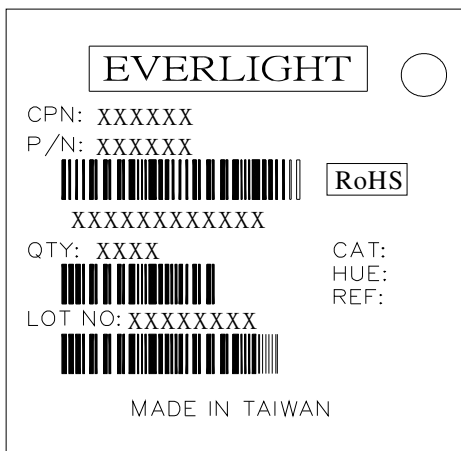

Reel Dimensions

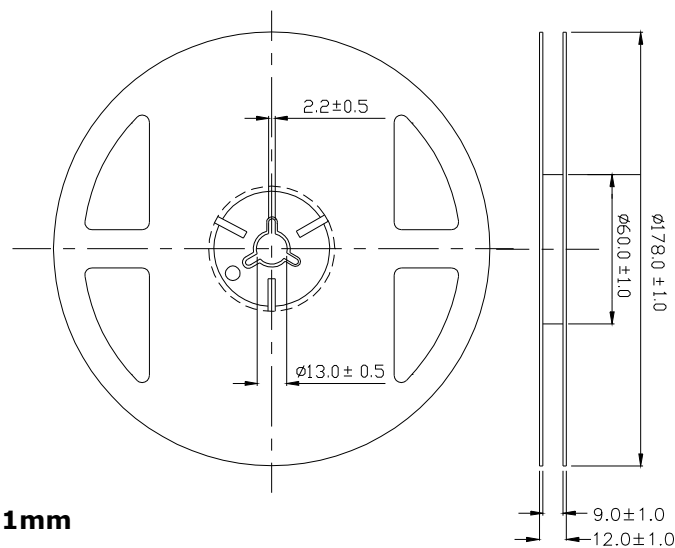

Unit: mm

Tolerance: ±0.1mm

Tape Dimensions

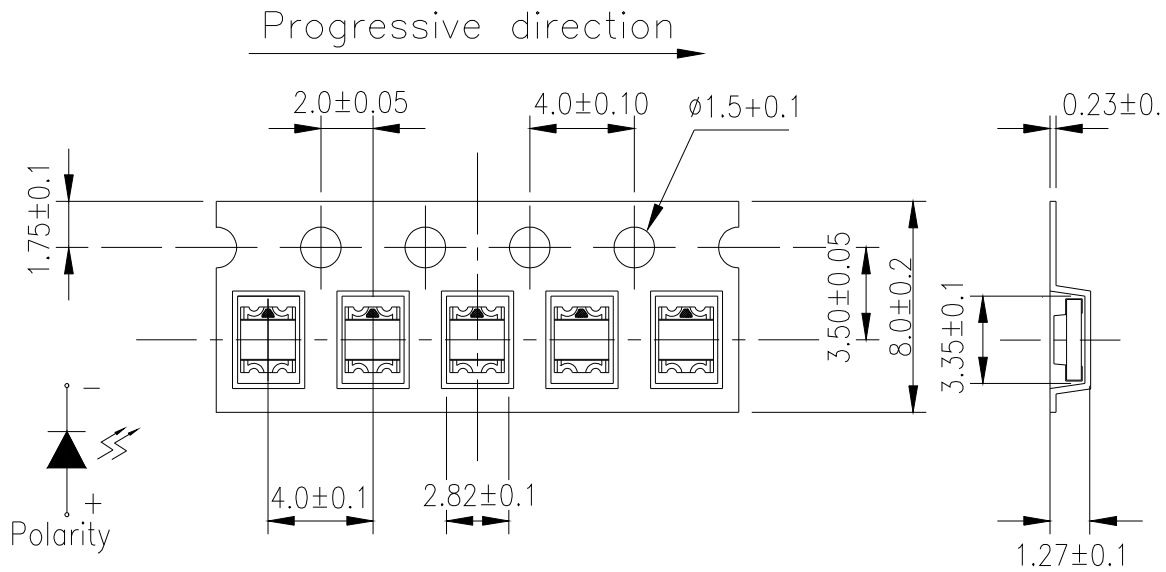

Unit: mm

Tolerance: $\pm 0.1\text{mm}$

Moisture Resistant Packaging

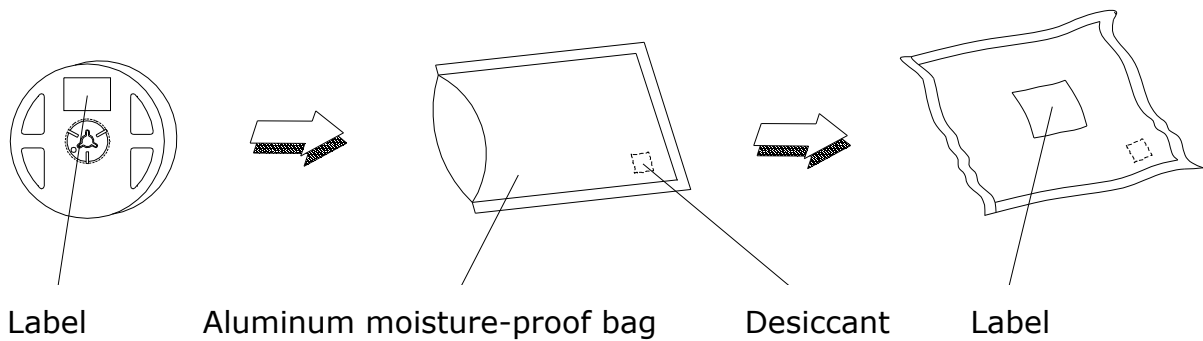



LIGHTING FOREVER

**Surface - Mount
RGB Color Sensor**

**CLS15-22C/L213R/TR8
CLS15-22C/L213G/TR8
CLS15-22C/L213B/TR8**

Notes

1. Above specification may be changed without notice. EVERLIGHT will reserve authority on material change for above specification.
2. When using this product, please observe the absolute maximum ratings and the instructions for using outlined in these specification sheets. EVERLIGHT assumes no responsibility for any damage resulting from use of the product which does not comply with the absolute maximum ratings and the instructions included in these specification sheets.
3. These specification sheets include materials protected under copyright of EVERLIGHT corporation. Please don't reproduce or cause anyone to reproduce them without EVERLIGHT's consent.