



DATA SHEET

UF300 thru UF3010

ULTRAFAST RECOVERY RECTIFIERS

VOLTAGE 50 to 1000 Volts **CURRENT** 3.0 Amperes

DO-201AD

Unit: inch(mm)

FEATURES

- Plastic package has Underwriters Laboratory Flammability Classification 94V-O utilizing Flame Retardant Epoxy Molding Compound
- Exceeds environmental standards of MIL-S-19500/228.
- Ultra Fast switching for high efficiency.
- Pb free product are available : 99% Sn above can meet Rohs environment substance directive request

MECHANICAL DATA

Case: Molded plastic, DO-201AD
 Terminals: Axial leads, solderable per MIL-STD-202G, Method 208
 Polarity: Band denotes cathode
 Mounting Position: Any
 Weight: 1.132 gram

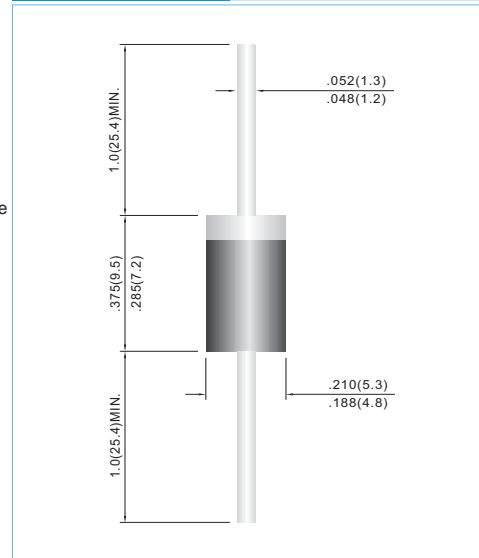

MAXIMUM RATINGS AND ELECTRICAL CHARACTERISTICS

Ratings at 25°C ambient temperature unless otherwise specified. Resistive or inductive load, 60Hz.

PARAMETER	SYMBOL	UF300	UF301	UF302	UF304	UF306	UF308	UF3010	UNITS
Maximum Recurrent Peak Reverse Voltage	V _{RRM}	50	100	200	400	600	800	1000	V
Maximum RMS Voltage	V _{RMS}	35	70	140	280	420	560	700	V
Maximum DC Blocking Voltage	V _{DC}	50	100	200	400	600	800	1000	V
Maximum Average Forward Current .375"(9.5mm) lead length at TA=55°C	I _{AV}	3.0							A
Peak Forward Surge Current : 8.3ms single half sine-wave superimposed on rated load(JEDEC method)	I _{FSM}	150							A
Maximum Forward Voltage at 3.0A	V _F	1.0		1.1		1.7		V	
Maximum DC Reverse Current TA=25°C at Rated DC Blocking Voltage TA=100°C	I _R	10.0 750							uA
Typical Junction capacitance (Note 1)	C _J	75				50			pF
Typical Thermal Resistance(Note 2)	R _{θJA}	20							°C / W
Maximum Reverse Recovery Time (Note 3)	T _{RR}	50				75			ns
Operating Junction and Storage Temperature Range	T _J , T _{STG}	-55 TO +150							°C

NOTES:

1. Measured at 1 MHz and applied reverse voltage of 4.0 VDC.
2. Thermal Resistance from Junction to Ambient and from Junction to lead length 0.375"(9.5mm) P.C.B. mounted.
3. Reverse Recovery Time I_F=.5A , I_R=1A , I_{TR}=-.25A



RATING AND CHARACTERISTIC CURVES

