

HEXFET POWER MOSFET

DESCRIPTION

The UTC **UF3205** uses advanced technology to provide excellent $R_{DS(ON)}$, fast switching, low gate charge, and extremely efficient. This device is suitable for all commercial-industrial applications at power dissipation levels to approximately 50 watts.

FEATURES

- * $R_{DS(ON)} < 8 \text{ m}\Omega @ V_{GS} = 10\text{V}$
- * Ultra Low Gate Charge (146 nC max)
- * Low Reverse Transfer Capacitance ($C_{RSS} = \text{typ. } 211 \text{ pF}$)
- * Fast Switching Capability
- * Avalanche Energy Specified
- * Improved dv/dt Capability, High Ruggedness

SYMBOL

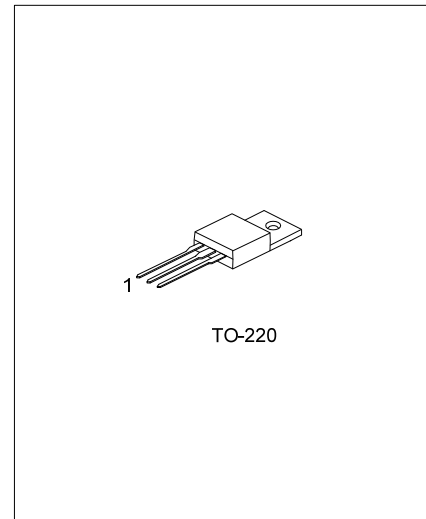
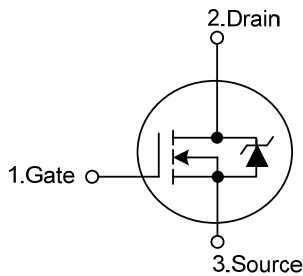

Lead-free: UF3205L
Halogen-free: UF3205G

ORDERING INFORMATION

Ordering Number			Package	Pin Assignment			Packing
Normal	Lead Free Plating	Halogen Free		1	2	3	
UF3205-TA3-T	UF3205L-TA3-T	UF3205G-TA3-T	TO-220	G	D	S	Tube

<p>UF3205L-TA3-T</p> <p>(1)Packing Type</p> <p>(2)Package Type</p> <p>(3)Lead Plating</p>	<p>(1) T: Tube</p> <p>(2) TA3: TO-220</p> <p>(3) G: Halogen Free, L: Lead Free, Blank: Pb/Sn</p>
---	--

■ ABSOLUTE MAXIMUM RATINGS

PARAMETER		SYMBOL	RATINGS	UNIT
Gate-Source Voltage		V_{GS}	± 20	V
Drain Current	Continuous ($V_{GS}=10V$)	I_D	110	A
	Pulsed (Note 2)	I_{DM}	390	
Avalanche Current (Note 2)		I_{AR}	62	A
Avalanche Energy	Repetitive(Note 2)	E_{AR}	20	mJ
	Single Pulsed(Note 3)	E_{AS}	1050	
Power Dissipation ($T_C=25^\circ C$)		P_D	200	W
Junction Temperature		T_J	+175	$^\circ C$
Storage Temperature		T_{STG}	-55 ~ +175	$^\circ C$

Note: 1. Absolute maximum ratings are those values beyond which the device could be permanently damaged.

Absolute maximum ratings are stress ratings only and functional device operation is not implied.

2. Pulse width limited by $T_{J(MAX)}$

3. $T_J=25^\circ C$, $L=138\mu H$, $R_G=25\Omega$, $I_{AS}=62A$

■ THERMAL DATA

PARAMETER	SYMBOL	MIN	TYP	MAX	UNIT
Junction to Ambient	θ_{JA}			62	$^\circ C/W$
Junction to Case	θ_{JC}			0.75	$^\circ C/W$

■ ELECTRICAL CHARACTERISTICS ($T_J=25^\circ C$, unless otherwise specified)

PARAMETER	SYMBOL	TEST CONDITIONS	MIN	TYP	MAX	UNIT
OFF CHARACTERISTICS						
Drain-Source Breakdown Voltage	BV_{DSS}	$V_{GS}=0V, I_D=250\mu A$	55			V
Drain-Source Leakage Current	I_{DSS}	$V_{DS}=55V, V_{GS}=0V$			25	μA
Gate-Source Leakage Current	I_{GSS}	$V_{GS}=\pm 20V, V_{DS}=0V$			± 100	nA
Breakdown Voltage Temperature Coefficient	$\Delta BV_{DSS}/\Delta T_J$	Reference to $25^\circ C, I_D=1mA$		0.057		$V/^\circ C$
ON CHARACTERISTICS						
Gate Threshold Voltage	$V_{GS(TH)}$	$V_{DS}=V_{GS}, I_D=250\mu A$	2.0		4.0	V
Static Drain-Source On-Resistance (Note)	$R_{DS(ON)}$	$V_{GS}=10V, I_D=62A$			8.0	m Ω
DYNAMIC PARAMETERS						
Input Capacitance	C_{ISS}	$V_{DS}=25V, V_{GS}=0V, f=1MHz$		3247		pF
Output Capacitance	C_{OSS}			781		pF
Reverse Transfer Capacitance	C_{RSS}			211		pF
SWITCHING PARAMETERS						
Total Gate Charge	Q_G	$V_{DS}=44V, I_D=62A, V_{GS}=10V$			146	nC
Gate Source Charge	Q_{GS}				35	nC
Gate Drain Charge	Q_{GD}				54	nC
Turn-ON Delay Time	$t_{D(ON)}$	$V_{DD}=28V, I_D=62A, R_G=4.5\Omega, V_{GS}=10V$ (Note)		14		ns
Turn-ON Rise Time	t_R			101		ns
Turn-OFF Delay Time	$t_{D(OFF)}$			50		ns
Turn-OFF Fall-Time	t_F			65		ns
Internal Drain Inductance	L_D			4.5		nH
Internal Source Inductance	L_S		7.5		nH	
SOURCE- DRAIN DIODE RATINGS AND CHARACTERISTICS						
Diode Forward Voltage	V_{SD}	$I_S=62A, V_{GS}=0V$			1.3	V
Maximum Continuous Drain-Source Diode Forward Current	I_S				110	A
Maximum Pulsed Drain-Source Diode Forward Current	I_{SM}				390	A
Body Diode Reverse Recovery Time	t_{RR}	$I_F=62A, di/dt=100A/\mu s$ (Note)		69	104	ns
Body Diode Reverse Recovery Charge	Q_{RR}			143	215	nC

Note: Pulse width $\leq 400\mu s$; duty cycle $\leq 2\%$.

■ TEST CIRCUITS AND WAVEFORMS

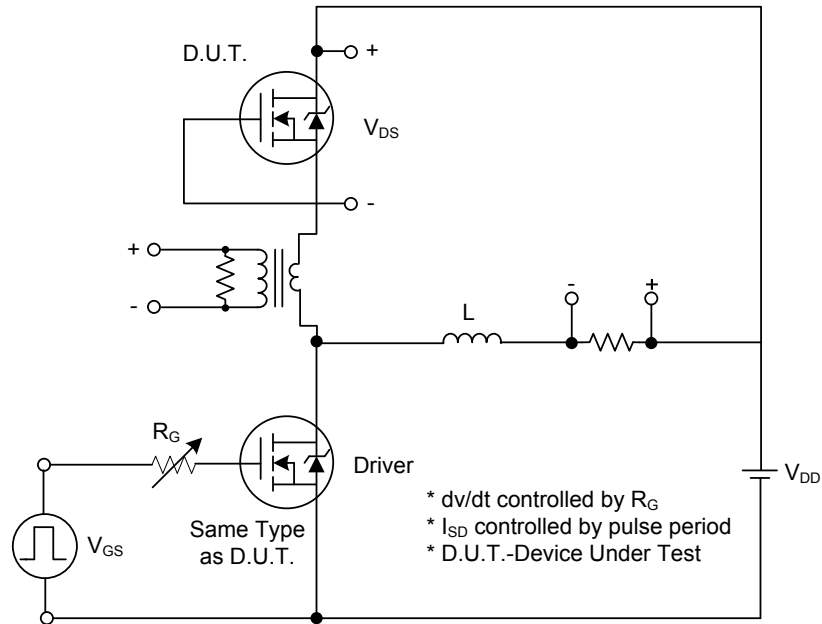

1A Peak Diode Recovery dv/dt Test Circuit

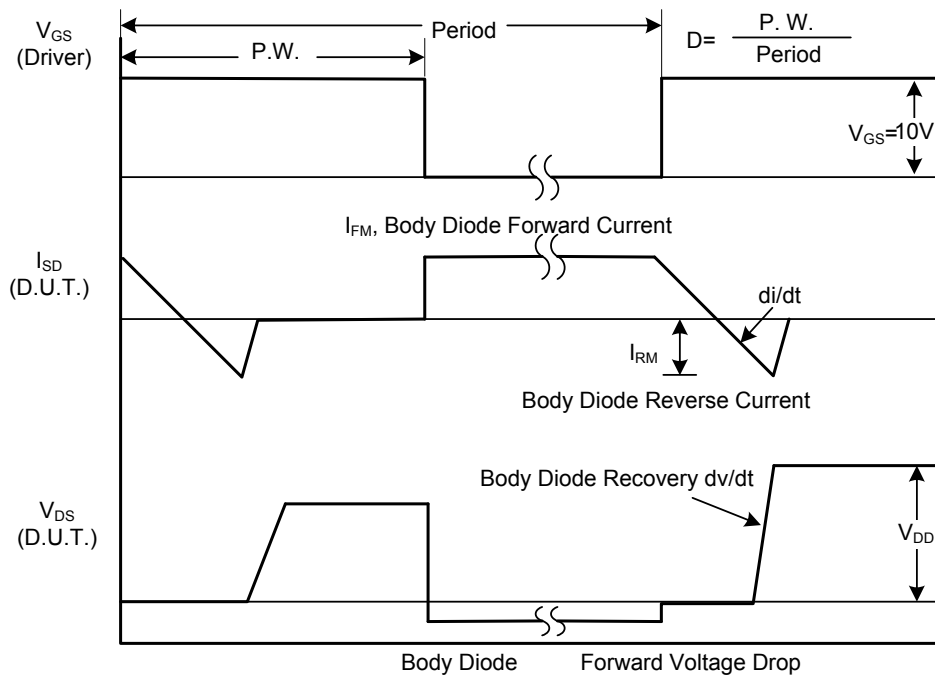

1B Peak Diode Recovery dv/dt Waveforms

■ TEST CIRCUITS AND WAVEFORMS (Cont.)

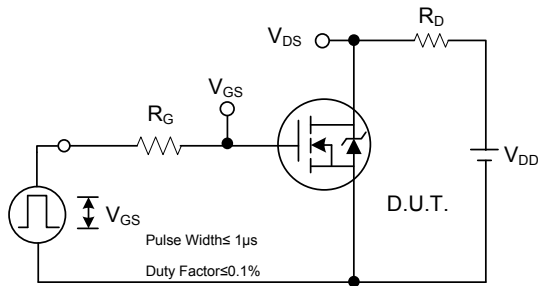

2A Switching Test Circuit

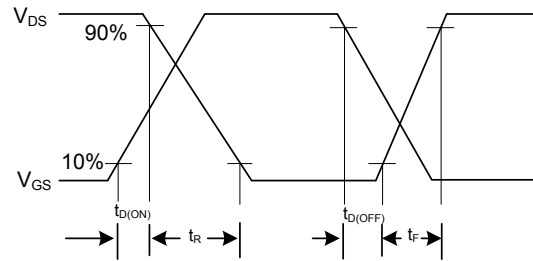

2B Switching Waveforms

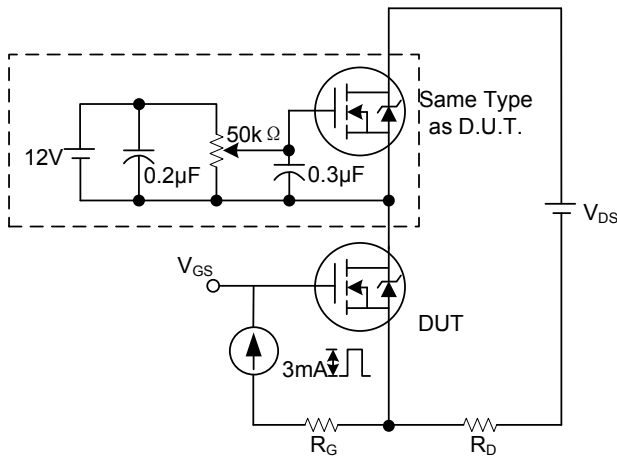

3A Gate Charge Test Circuit

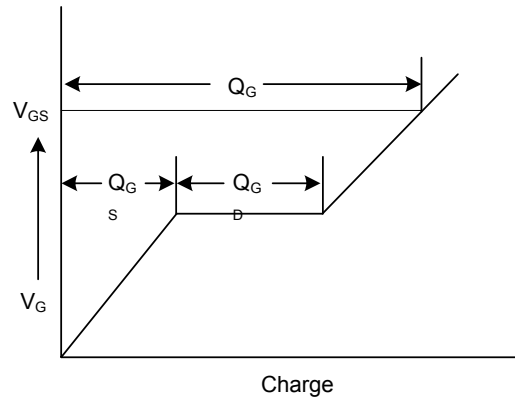

3B Gate Charge Waveform

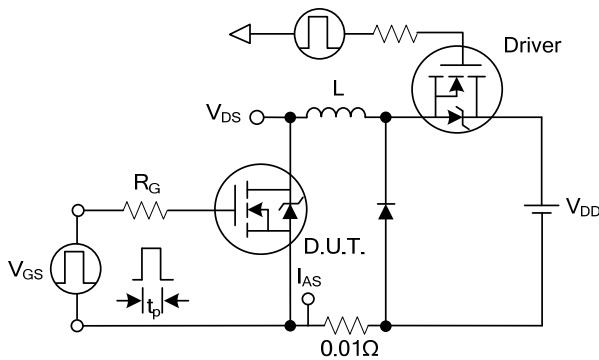

4A Unclamped Inductive Switching Test Circuit

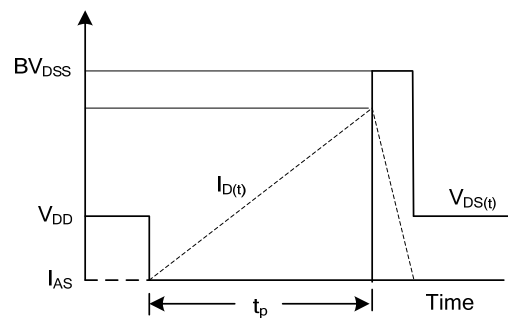

4B Unclamped Inductive Switching Waveforms

UTC assumes no responsibility for equipment failures that result from using products at values that exceed, even momentarily, rated values (such as maximum ratings, operating condition ranges, or other parameters) listed in products specifications of any and all UTC products described or contained herein. UTC products are not designed for use in life support appliances, devices or systems where malfunction of these products can be reasonably expected to result in personal injury. Reproduction in whole or in part is prohibited without the prior written consent of the copyright owner. The information presented in this document does not form part of any quotation or contract, is believed to be accurate and reliable and may be changed without notice.

