

MRSS23E

Low voltage operating type Built-in IC ultra-minimum MR sensor

• FEATURES

- E Micro power ($6\mu\text{W}(\text{typ})$; $V_{cc}=1.8\text{V}$) and High-sensitivity($1.7\text{mT}(\text{typ})$) (suited for battery-operation)
- E Operating ambient temperature range (-40°C to $+85^{\circ}\text{C}$)
- E Operating in one way magnetic field
- E Operating with independent pole (easily manufacture)
- E Lead free products

1.Dimension (Unit : mm)

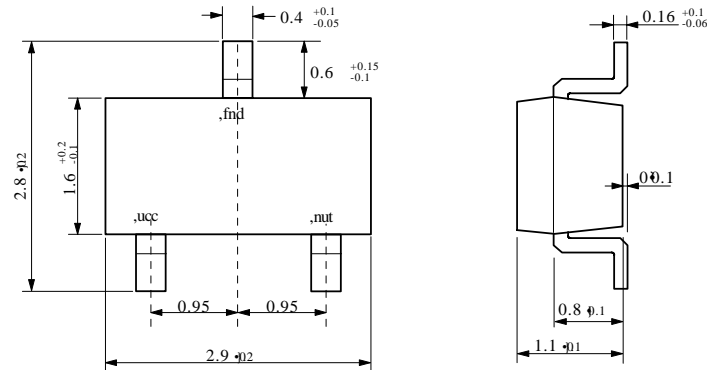

2.Fundamental Operation

2-1.Direction of Magnetic Field

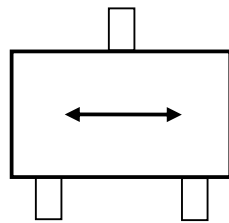

2-2.Circuit Block

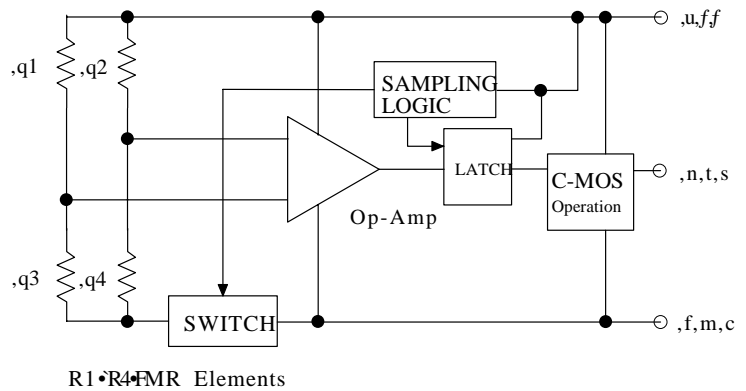

2-3.Performance Characteristics ($25\pm 3^{\circ}\text{C}$)

	Operating require Condition	Output Voltage
When power switch is ON	$H = 0 \text{ mT}$ (Magnetic Flux Density) [0 A/m (Magnetic Field Strength)]	Hi-level
When magnetic field is applied	$H \nabla 1.7(\text{Typ})\text{mT}$ (Magnetic Flux Density) [1.4kA/m (Magnetic Field Strength)]	Lo-level
When magnetic field is applied	$H \bullet 0.5 \text{ mT}$ (Magnetic Flux Density) [0.6kA/m (Magnetic Field Strength)]	Hi-level

MRSS23E

3.Performance

3-1.Operating Conditions Recommended

(Ta = 25±3°C unless otherwise specified)

Item	Output	Condition	Min	Std	Max	Unit
Source Voltage	-	-	1.6	1.8	3.5	V
Source Current	-	Vcc=3V	-	3	-	μA
Ambient Temperature	-	-	-40	25	85	°C
Output Voltage	VOH	Vcc=1.8V Iout=1mA	1.6	-	-	V
	VOL	VCC=1.8V Iout=-1mA	-	-	0.2	V
Operating Magnetic Field	Hi-level output Hon		-	1.7 (1.4)	2.2 (1.8)	mT ^(*1)
	Lo-level output Hoff		0.5 (0.4)	-	-	(kA/m)

*1) 1 [mT] (SI) = 10 [G] (CGS)

3-2.Absolute Maximum Ratings

(Ta = 25±3°C unless otherwise specified)

Item	Condition	Specifications	Unit
Source Voltage	-	6.0	V
Storage Temperature	-	-40 ~ 125	°C

The products and product specifications described in this material are subject to change without notice for reasons of modification or improvement.

MRSS23E

◆ Recommended Mount Pad

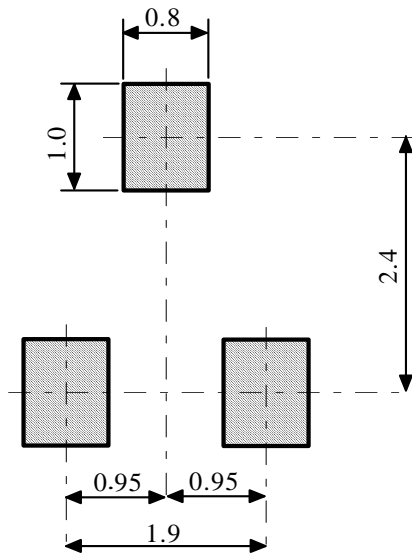

(Unit : mm)

The products and product specifications described in this material are subject to change without notice for reasons of modification or improvement.