

MRSM75

Rotation detection MR sensor

FEATURES

- Rotation Detection sensor
 - Various usages for rotation detection
- Operating with independent pole
- Superior Temperature stability
- Wide operating source voltage
- No contact detection sensor
 - dependable for various use

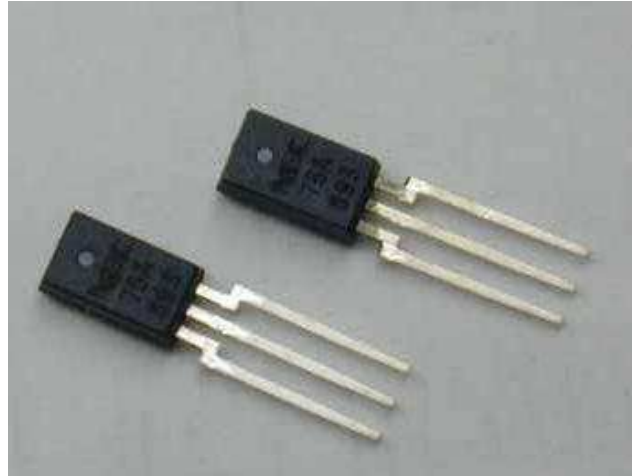

FUNDEMENTAL OPERATION

Direction of Magnetic Field

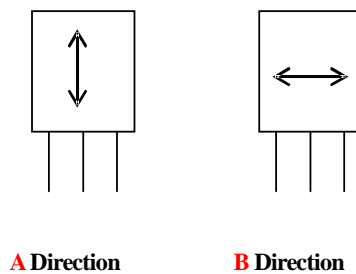

Circuit Block

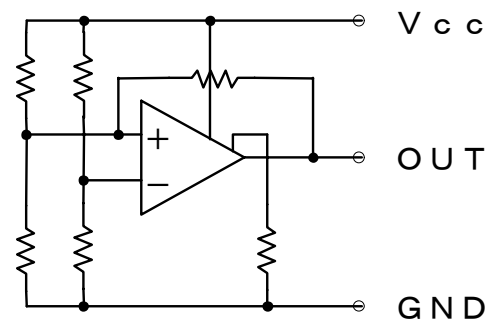

PERFORMANCE

Performance Characteristics (Ta = 25±3°C unless otherwise specified)

	Operating require Condition	Output Voltage
When power switch is ON	H = 0.0mT(Magnetic Flux Density) {0 A/m (Magnetic Field Strength)}	Unfixed
When magnetic field is applied To A direction	H ≧ 3.0(Typ)mT(Magnetic Flux Density) {2.4kA/m (Magnetic Field Strength)}	Hi-level
When magnetic field is applied To B direction	H ≧ 3.0 mT(Magnetic Flux Density) {2.4kA/m (Magnetic Field Strength)}	Lo-level

Operating Conditions Recommended (Ta = 25±3°C unless otherwise specified)

Item	Symbol	Condition	Min	Std	Max	Unit
Source Voltage	Vcc	-	3	12	30	V
Load Resistance	RL	Vcc=12V	10.0	-	-	kΩ
Ambient Temperature	Ta	-	-20	25	80	°C
Applied magnetic Field	H	-	3.0 (2.4)	-	-	mT ^(*1) (kA/m) (*2)

*1) 1 [mT](SI) = 10 [G] (CGS) *2) () = [kA/m](SI)

Electrical Characteristics (Ta = 25±3°C unless otherwise specified)

Item	Symbol	Condition	Min	Std	Max	Unit
Circuit Current	Icc	Vcc=12V Output open	—	—	5	mA
Output Voltage 1	VoH	RL=10 k Ω Vcc=12V	10	—	—	V
Output Voltage 2	VoL	RL=10 k Ω Vcc=12V	—	—	1	V
Response Frequency	f(max)	Vcc=12V	—	—	2	kHz