

High Efficiency Synchronous Step-up DC/DC Converter

FEATURES

- High efficiency. (93% when $V_{IN}=2.4V$, $V_{OUT}=3.3V$, $I_{OUT}=200mA$)
- Output current up to 500mA. (SS6610 at $V_{IN}=2.4V$ and $V_{OUT}=3.3V$)
- Quiescent supply current of $20\mu A$.
- Power-saving shutdown mode ($0.1\mu A$ typical).
- Internal synchronous rectifier (no external diode required).
- On-chip low-battery detector.
- Low battery hysteresis
- Space-saving package: MSOP-8

APPLICATIONS

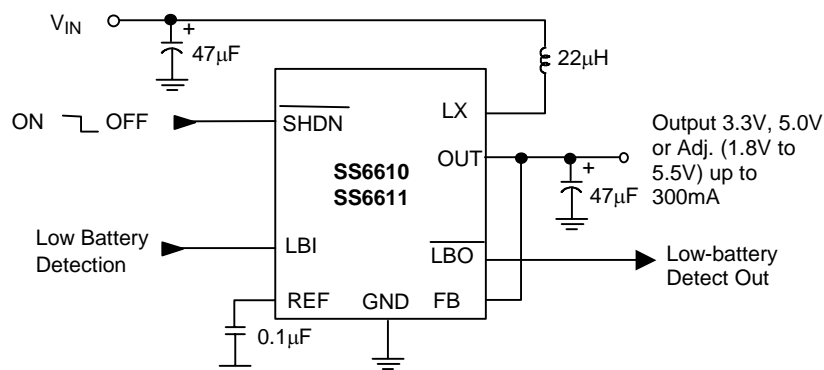
- Palmtop & Notebook Computers.
- PDAs
- Wireless Phones
- Pocket Organizers.
- Digital Cameras.
- Hand-Held Devices with 1 to 3 Cells of NiMH/NiCd Batteries.

DESCRIPTION

The SS6610/SS6611 are high-efficiency step-up DC/DC converters, with a start-up voltage as low as 0.8V, and an operating voltage down to 0.7V. Consuming only $20\mu A$ of quiescent current, these devices include a built-in synchronous rectifier that reduces size and cost by eliminating the need for an external Schottky diode, and improves overall efficiency by minimizing losses.

The switching frequency can range up to 500KHz depending on the load and input voltage. The output voltage can be easily set; by two external resistors or 1.8V to 5.5V; connecting FB to OUT to get 3.3V; or connecting to GND to get 5.0V. The peak current of the internal switch is fixed at 1.0A (SS6610) or 0.65A (SS6611) for design flexibility.

TYPICAL APPLICATION CIRCUIT



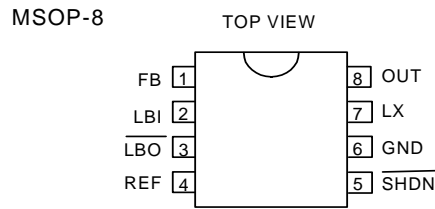
ORDERING INFORMATION

SS6610CX XX
 SS6611CX XX

└─ Packing
 TR: Tape and reel

└─ Package type
 O: MSOP-8

Example: SS6610COTR
 → in MSOP-8 package supplied
 on tape and reel

PIN CONFIGURATION

ABSOLUTE MAXIMUM RATINGS

Supply Voltage (OUT to GND).....	8.0V
Switch Voltage (LX to GND).....	$V_{OUT} + 0.3V$
SHDN, LBO to GND.....	6.0V
LBI, REF, FB, to GND.....	$V_{OUT} + 0.3V$
Switch Current (LX).....	-1.5A to +1.5A
Output Current (OUT).....	-1.5A to +1.5A
Operating Temperature Range.....	-40°C ~ +85°C
Storage Temperature Range.....	-65°C ~ 150°C

TEST CIRCUIT

Refer to typical application circuit.

ELECTRICAL CHARACTERISTICS

($V_{IN} = 2.0V$, $V_{OUT} = 3.3V$ (FB = V_{OUT}), $R_L = \infty$, $T_A = 25^\circ C$, unless otherwise specified.)

PARAMETER	TEST CONDITIONS	MIN.	TYP.	MAX.	UNIT
Minimum Input Voltage			0.7		V
Operating Voltage		1.1		5.5	V
Start-Up Voltage	$R_L = 3k\Omega$ (Note1)		0.8	1.1	V
Start-Up Voltage Tempco			-2		mV/°C
Output Voltage Range	$V_{IN} < V_{OUT}$	1.8		5.5	
Output Voltage	FB = V_{OUT}	3.17	3.3	3.43	V
Steady State Output Current (Note 2)	FB=OUT ($V_{OUT} = 3.3V$)	SS6610	300	350	mA
		SS6611	150	300	
	FB=GND ($V_{OUT} = 5.0V$)	SS6610	180	230	
		SS6611	90	160	
Reference Voltage	$I_{REF} = 0$	1.199	1.23	1.261	V
Reference Voltage Temp. Coeff.			0.024		mV/°C
Reference Load Regulation	$I_{REF} = 0$ to $100\mu A$		10	30	mV
Reference Line Regulation	$V_{OUT} = 1.8V$ to $5.5V$		5	10	mV/V
FB , LBI Input Threshold		1.199	1.23	1.261	V
Internal switch On-Resistance	$I_{LX} = 100mA$		0.3	0.6	Ω
LX Switch Current Limit	SS6610	0.80	1.0	1.25	A
	SS6611	0.50	0.65	0.85	
LX Leakage Current	$V_{LX} = 0V \sim 4V$; $V_{OUT} = 5.5V$		0.05	1	μA
Operating Current into OUT (Note 3)	$V_{FB} = 1.4V$, $V_{OUT} = 3.3V$		20	35	μA
Shutdown Current into OUT	$\overline{SHDN} = GND$		0.1	1	μA
Efficiency	$V_{OUT} = 3.3V$, $I_{LOAD} = 200mA$		90		%
	$V_{OUT} = 2V$, $I_{LOAD} = 1mA$		85		

ELECTRICAL CHARACTERISTICS (Continued)

PARAMETER	TEST CONDITIONS	MIN.	TYP.	MAX.	UNIT
LX Switch On-Time	$V_{FB} = 1V$, $V_{OUT} = 3.3V$	2	4	7	μs
LX Switch Off-Time	$V_{FB} = 1V$, $V_{OUT} = 3.3V$	0.6	0.9	1.4	μs
FB Input Current	$V_{FB} = 1.4V$		0.03	50	nA
LBI Input Current	$V_{LBI} = 1.4V$		1	50	nA
\overline{SHDN} Input Current	$V_{\overline{SHDN}} = 0$ or V_{OUT}		0.07	50	nA
\overline{LBO} Low Output Voltage	$V_{LBI} = 0$, $I_{SINK} = 1mA$		0.2	0.4	μA
\overline{LBO} Off Leakage Current	$V_{\overline{LBO}} = 5.5V$, $V_{LBI} = 5.5V$		0.07	1	
LBI Hysteresis			50		mV
\overline{SHDN} Input Voltage	V_{IL}			0.2 V_{OUT}	V
	V_{IH}	0.8 V_{OUT}			

Note 1: Start-up voltage operation is guaranteed without the addition of an external Schottky diode between the input and output.

Note 2: Steady-state output current indicates that the device maintains output voltage regulation under load.

Note 3: Device is bootstrapped (power to the IC comes from OUT). This correlates directly with the actual battery supply.

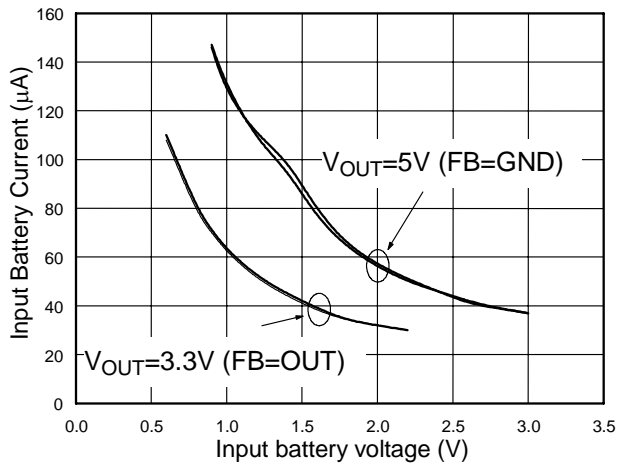
TYPICAL PERFORMANCE CHARACTERISTICS


Fig. 1 No-Load Battery Current vs. Input Battery

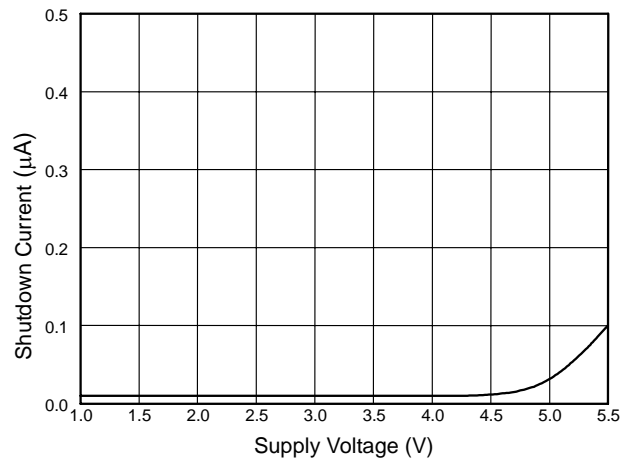


Fig. 2 Shutdown Current vs. Supply Voltage

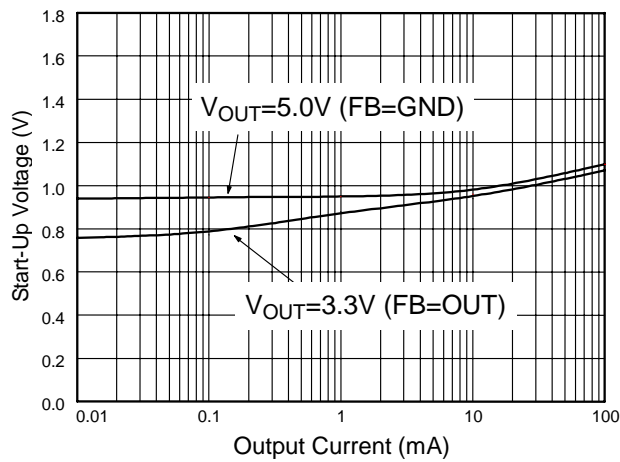


Fig. 3 Start-Up Voltage vs. Output Current

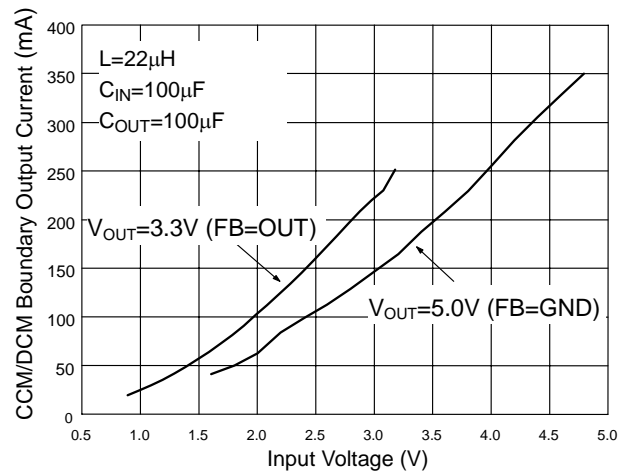


Fig. 4 Turning Point between CCM & DCM

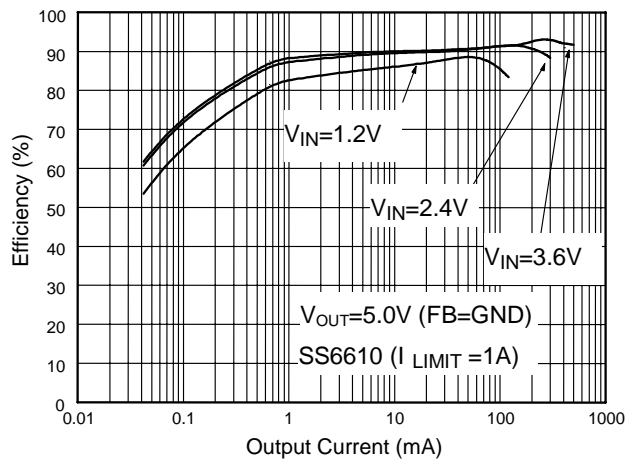


Fig. 5 Efficiency vs. Load Current (ref. to Fig.33)

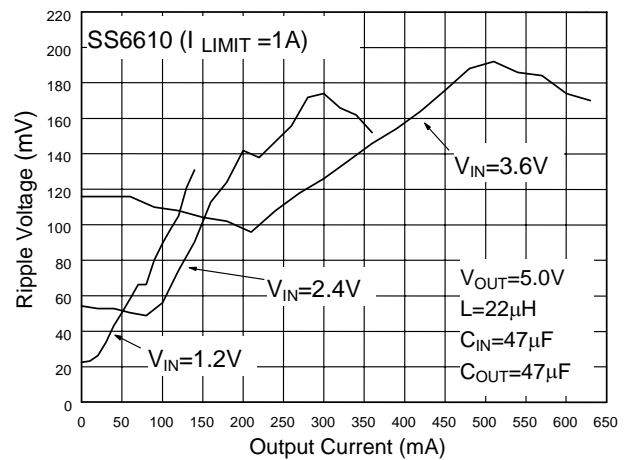
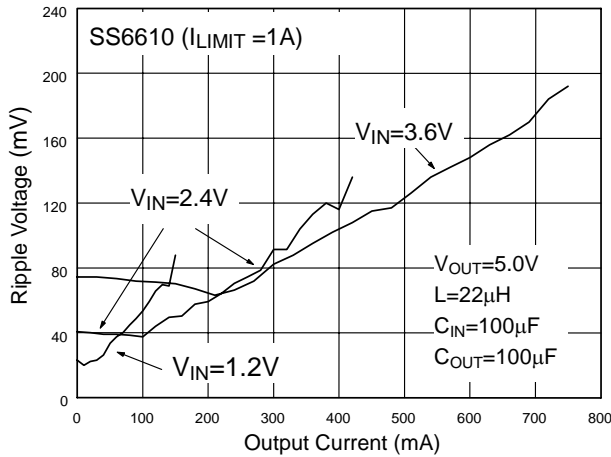
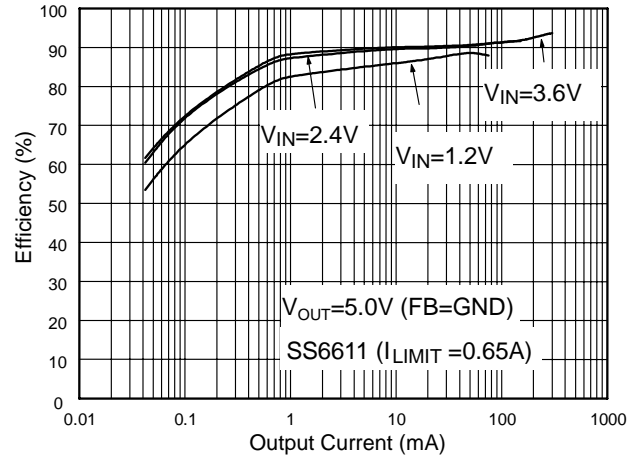
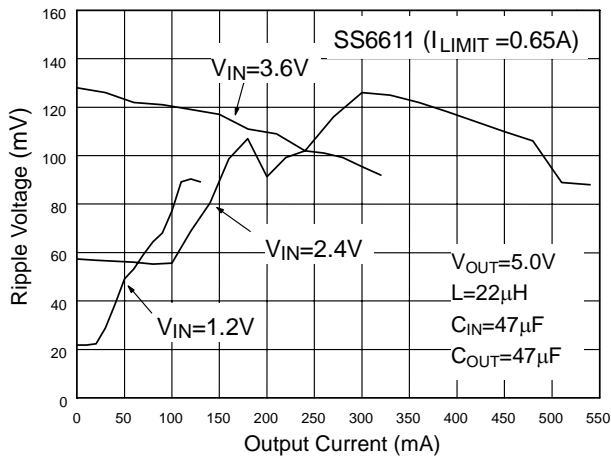
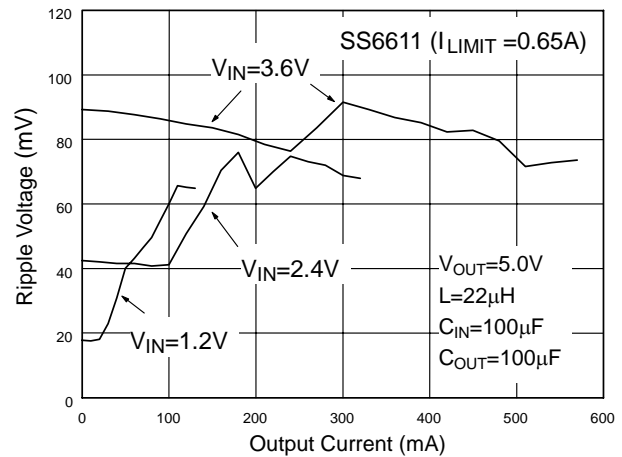
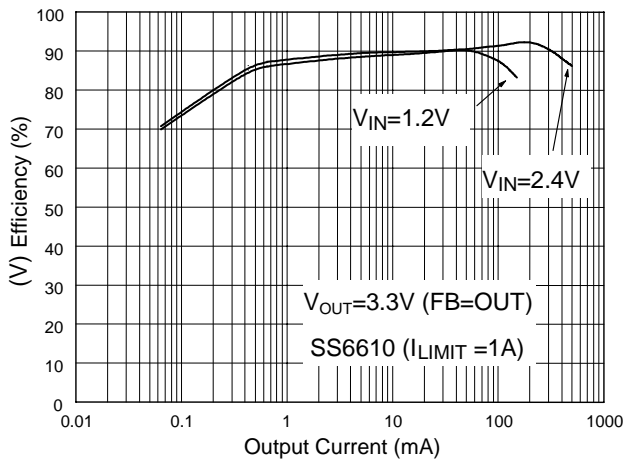
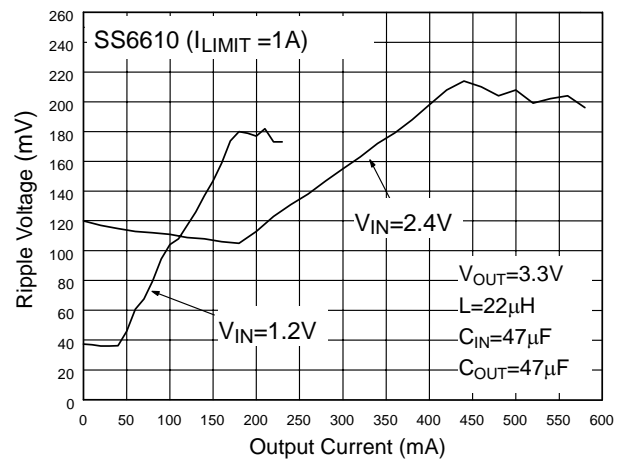
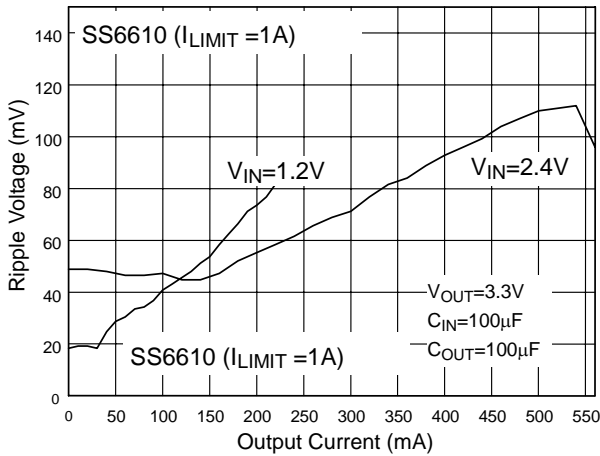
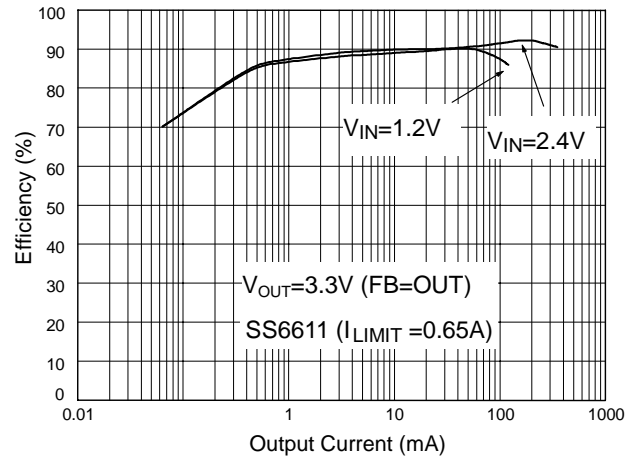
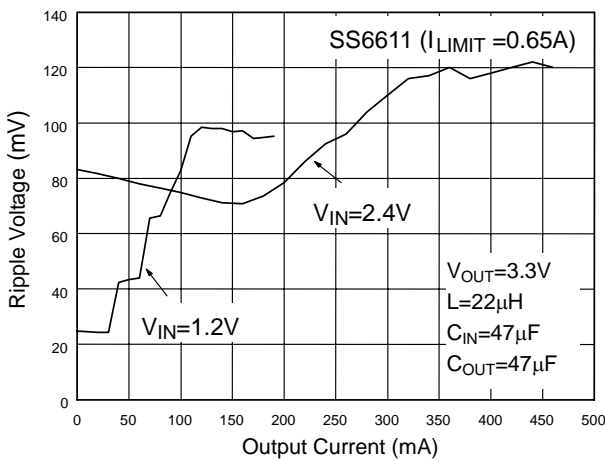
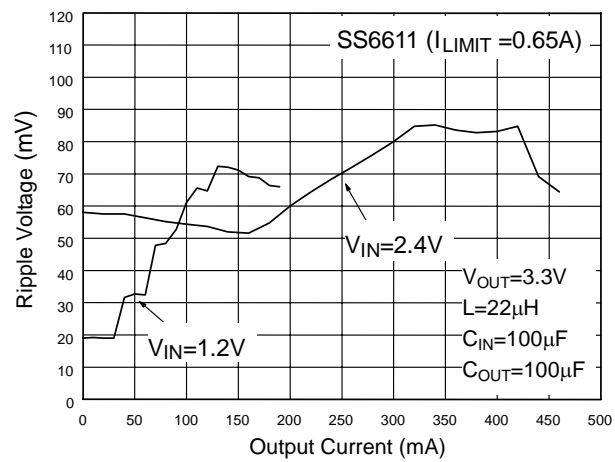
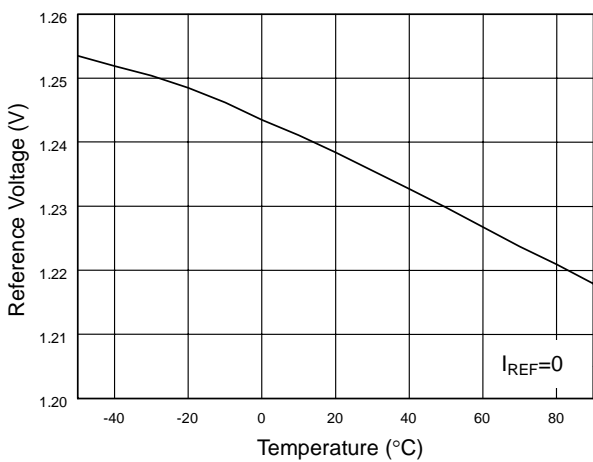
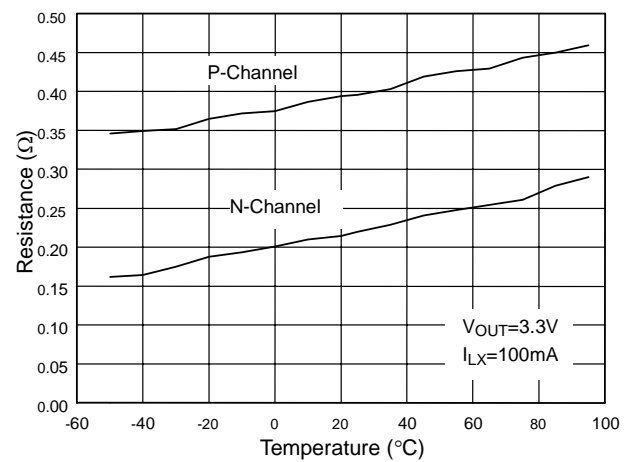
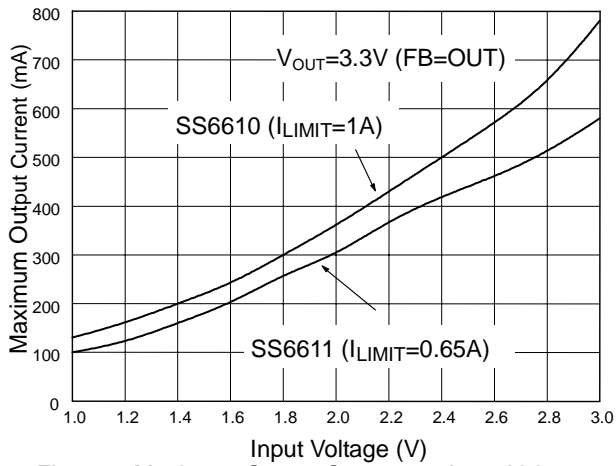
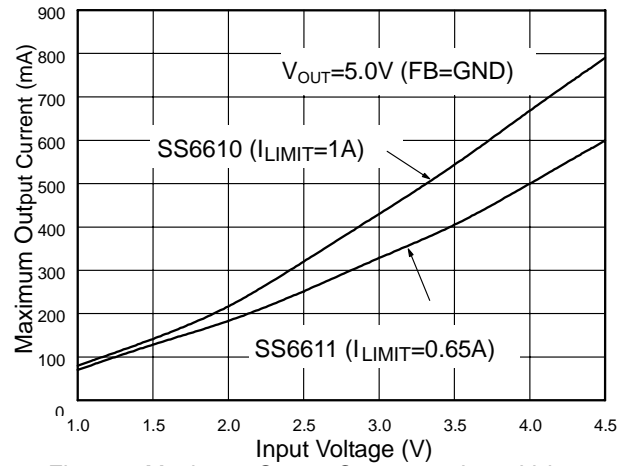
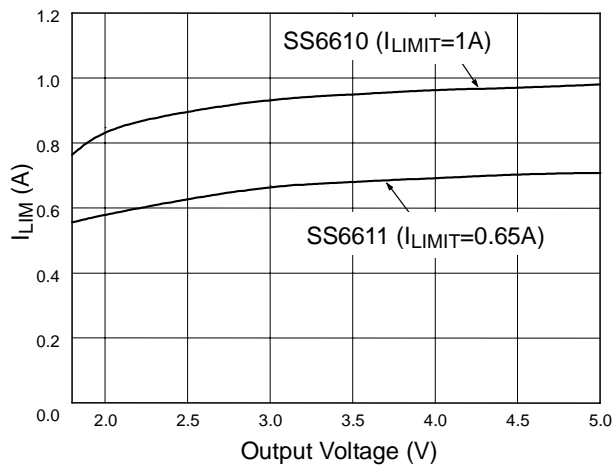
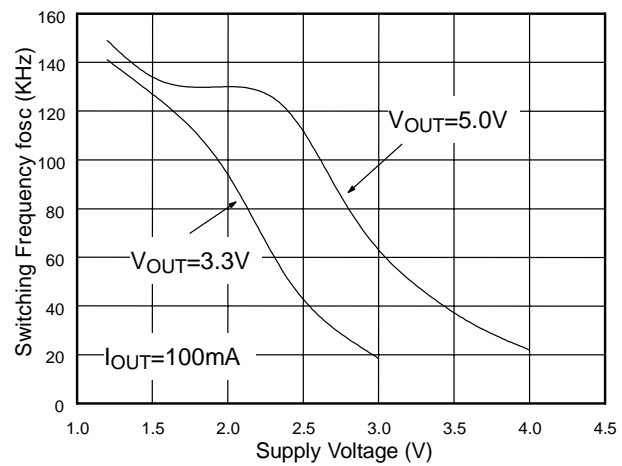
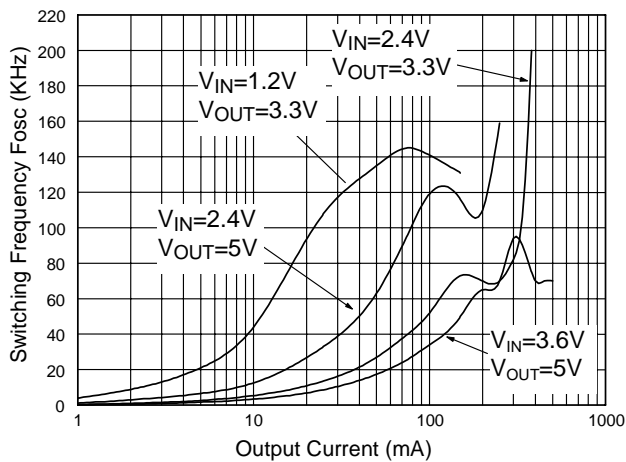
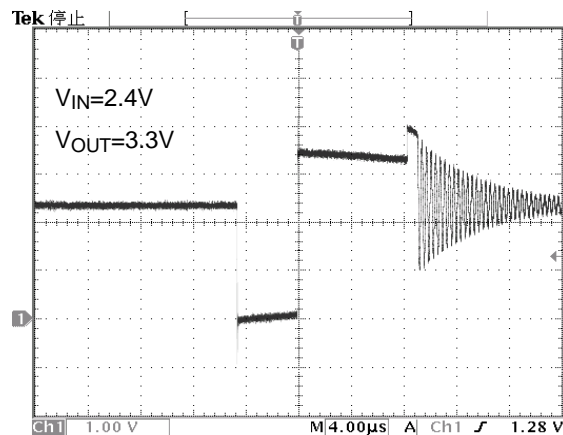


Fig. 6 Ripple Voltage (ref. to Fig.33)

TYPICAL PERFORMANCE CHARACTERISTICS (Continued)

Fig. 7 Ripple Voltage (ref. to Fig.33)

Fig. 8 Efficiency vs. Load Current (ref. to Fig.33)

Fig. 9 Ripple Voltage (ref. to Fig.33)

Fig. 10 Ripple Voltage (ref. to Fig.33)

Fig. 11 Efficiency vs. Load Current (ref. to Fig.32)

Fig. 12 Ripple Voltage (ref. to Fig.32)

TYPICAL PERFORMANCE CHARACTERISTICS (Continued)

Fig. 13 Ripple Voltage (ref. to Fig.32)

Fig. 14 Efficiency vs. Load Current (ref. to Fig.32)

Fig. 15 Ripple Voltage (ref. to Fig.32)

Fig. 16 Ripple Voltage (ref. to Fig.32)

Fig. 17 Reference Voltage vs. Temperature

Fig. 18 Switch Resistance vs. Temperature

TYPICAL PERFORMANCE CHARACTERISTICS (Continued)

Fig. 19 Maximum Output Current vs. Input Voltage

Fig. 20 Maximum Output Current vs. Input Voltage

Fig. 21 Inductor Current vs. Output Voltage

Fig. 22 Switching Frequency vs. Supply Voltage

Fig. 23 Switching Frequency vs. Output Current

Fig. 24 LX Switching Waveform

TYPICAL PERFORMANCE CHARACTERISTICS (Continued)

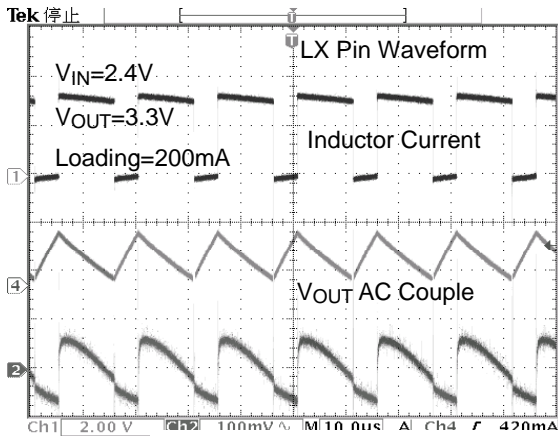


Fig. 25 Heavy Load Waveform

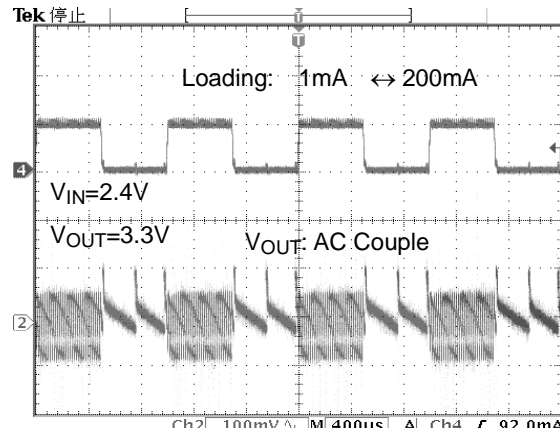


Fig. 26 Load Transient Response

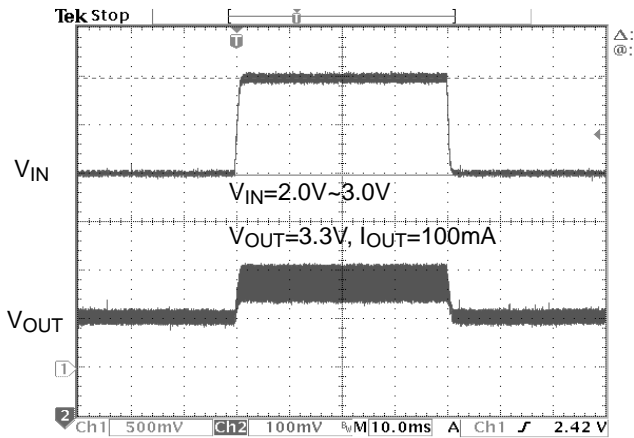


Fig. 27 Line Transient Response

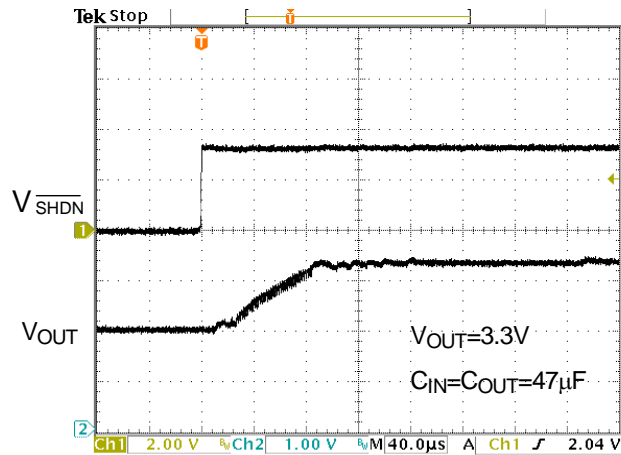


Fig. 28 Exiting Shutdown

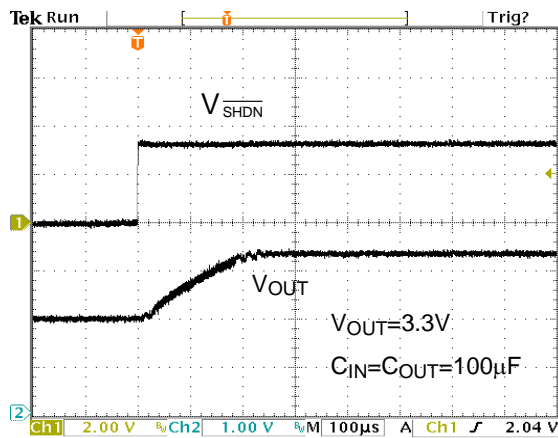


Fig. 29 Exiting Shutdown

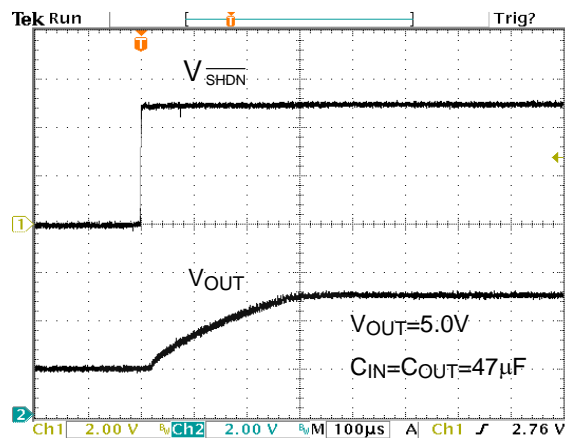


Fig. 30 Exiting Shutdown

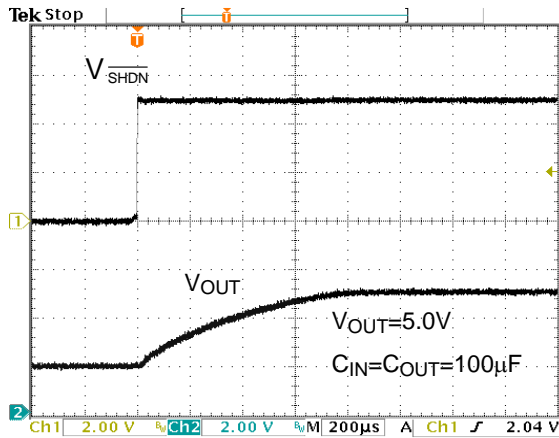
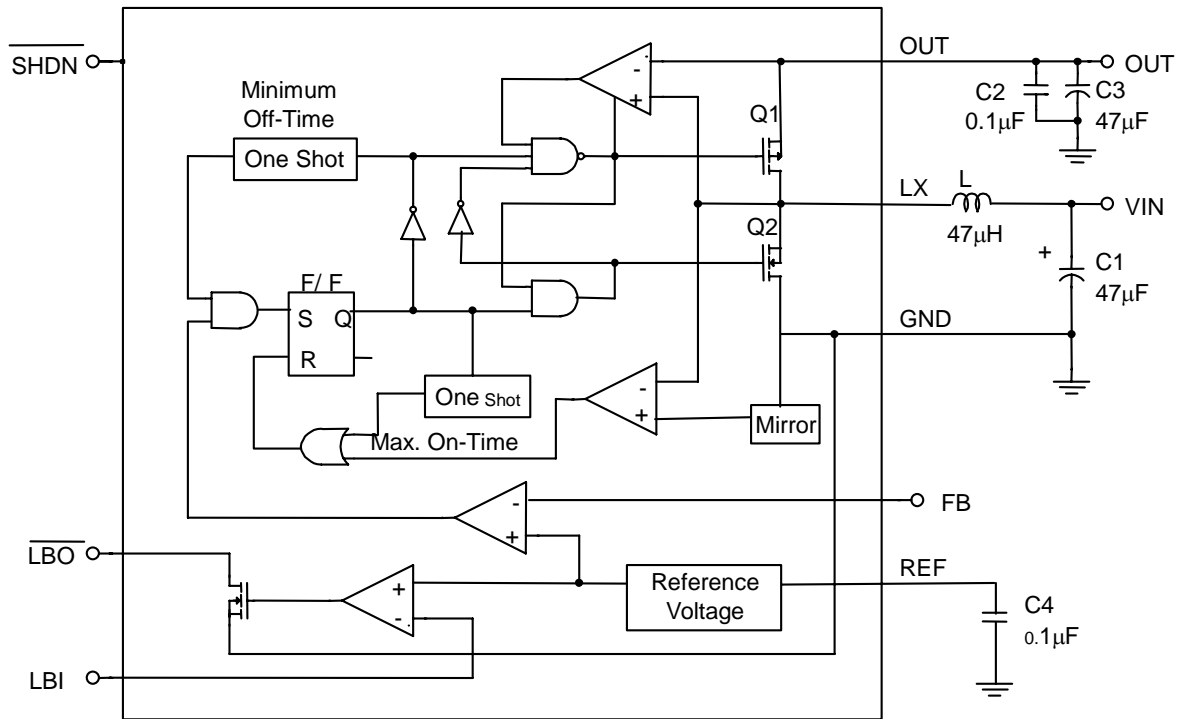
TYPICAL PERFORMANCE CHARACTERISTICS (Continued)


Fig. 31 Exiting Shutdown

BLOCK DIAGRAM


PIN DESCRIPTIONS

PIN 1: FB-	Connecting to OUT to get +3.3V output, connecting to GND to get +5.0V output, or using a resistor network to set the output voltage from +1.8V to +5.5V.	PIN 4: REF-	1.23V reference voltage. Bypass with a 0.1 μ F capacitor.
PIN 2: LBI-	Low-battery comparator input. Internally set at +1.23V to trip.	PIN 5: $\overline{\text{SHDN}}$ -	Shutdown input. High=operating, low=shutdown.
PIN 3: $\overline{\text{LBO}}$ -	Open-drain low battery comparator output. Output is low when V_{LBI} is <1.23V. $\overline{\text{LBO}}$ is high impedance during shutdown.	PIN 6: GND-	Ground
		PIN 7: LX-	N-channel and P-channel power MOSFET drain.
		PIN 8: OUT-	Power output. OUT provides bootstrap power to the IC.

APPLICATION INFORMATION

Overview

The SS6610/11 series are high-efficiency, step-up DC/DC converters, featuring a built-in synchronous rectifier, which reduces size and cost by eliminating the need for an external Schottky diode. The start-up voltage of the SS6610 and SS6611 is as low as 0.8V and it operates with an input voltage down to 0.7V. Quiescent supply current is only 20 μ A.

The internal P-MOSFET on-resistance is typically 0.3 Ω to improve overall efficiency by minimizing AC losses. The output voltage can be easily set; by two external resistors for 1.8V to 5.5V; connecting FB to OUT to get 3.3V; or connecting to GND to get 5.0V. The peak current of the internal switch is fixed at 1.0A (SS6610) or 0.65A (SS6611) for design flexibility. The current limits of the SS6610 and SS6611 are 1.0A and 0.65A respectively. The lower current limit allows the use of a physically smaller inductor in space-sensitive applications.

PFM Control Scheme

A key feature of the SS6610 series is a unique minimum-off-time, constant-on-time, current-limited, pulse-frequency-modulation (PFM) control scheme (see BLOCK DIAGRAM) with ultra-low quiescent

current. The peak current of the internal N-MOSFET power switch can be fixed at 1.0A (SS6610) or 0.65A (SS6611). The switch frequency depends on either loading conditions or input voltage, and can range up to 500KHz. It is governed by a pair of one-shots that set a minimum off-time (1 μ s) and a maximum on-time (4 μ s).

Synchronous Rectification

Using the internal synchronous rectifier eliminates the need for an external Schottky diode, reducing the cost and board space. During the cycle of off-time, the P-MOSFET turns on and shuts the N-MOSFET off. Due to the low turn-on resistance of the MOSFET, the synchronous rectifier significantly improves efficiency without an additional external Schottky diode. Thus, the conversion efficiency can be as high as 93%.

Reference Voltage

The reference voltage (REF) is nominally 1.23V for excellent T.C. performance. In addition, the REF pin can source up to 100 μ A to external circuit with good load regulation (<10mV). A bypass capacitor of 0.1 μ F is required for proper operation and good performance.

Shutdown

The whole circuit is shutdown when $\overline{V_{SHDN}}$ is low. In shutdown mode, the current can flow from the battery to the output due to the body diode of the P-MOSFET. V_{OUT} falls to approximately $(V_{in} - 0.6V)$ and LX remains high impedance. The capacitance and load at OUT determine the rate at which V_{OUT} decays. Shutdown can be pulled as high as 6V. Regardless of the voltage at OUT.

Selecting the Output Voltage

V_{OUT} can be simply set to 3.3V/5.0V by connecting the FB pin to OUT/GND due to the use of an internal resistor divider in the IC (Fig.32 and Fig.33). In order to adjust output voltage, a resistor divider is connected to V_{OUT} , FB, GND (Fig.34). V_{out} can be calculated by the following equation:

$$R5=R6 [(V_{OUT} / V_{REF})-1] \dots\dots\dots(1)$$

where $V_{REF}=1.23V$ and V_{OUT} ranges from 1.8V to 5.5V. The recommended $R6$ is 240k Ω .

Low-Battery Detection

The SS6610 series contains an on-chip comparator with 50mV internal hysteresis (REF , $REF+50mV$) for low battery detection. If the voltage at LBI falls below the internal reference voltage, LBO (an open-drain output) sinks current to GND.

Component Selection

1. Inductor Selection

An inductor value of 22 μ H performs well in most applications. The SS6610 series also work with inductors in the 10 μ H to 47 μ H range. An inductor with higher peak inductor current creates a higher output voltage ripple ($I_{PEAK} \times$ output filter capacitor ESR). The inductor's DC resistance significantly affects efficiency. We can calculate the maximum output current as follows:

$$I_{OUT(MAX)} = \frac{V_{IN}}{V_{OUT}} \left[I_{LIM} - t_{OFF} \left(\frac{V_{OUT} - V_{IN}}{2 \times L} \right) \right] \eta$$

$$\dots\dots\dots(2)$$

where $I_{OUT(MAX)}$ =maximum output current in amps

V_{IN} =input voltage

L =inductor value in μ H

η =efficiency (typically 0.9)

t_{OFF} =LX switch' off-time in μ s

I_{LIM} =1.0A or 0.65A

2. Capacitor Selection

The output ripple voltage is related to the peak inductor current and the output capacitor ESR. Besides output ripple voltage, the output ripple current may also be of concern. A filter capacitor with low ESR is helpful to the efficiency and the steady state output current of the SS6610 series. Therefore a NIPPON MCM Series tantalum capacitor of 100 μ F/6V is recommended. A smaller capacitor (down to 47 μ F with higher ESR) is acceptable for light loads or in applications that can tolerate higher output ripple.

3. PCB Layout and Grounding

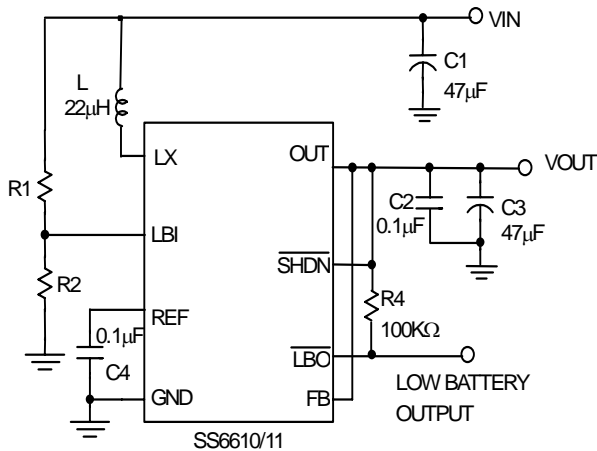
Since the SS6610/11's switching frequency can range up to 500kHz, the SS6610/11 can be very sensitive. Careful printed circuit layout is important for minimizing ground bounce and noise. The OUT pin should be as clear as possible, and the GND pin should be placed close to the ground plane. Keep the IC's GND pin and the ground leads of the input and output filter capacitors less than 0.2in (5mm) apart. In addition, keep all connection to the FB and LX pins as short as possible. In particular, when using external feedback resistors, locate them as close to the FB as possible. To maximize output power and efficiency, and minimize output ripple voltage, use a ground plane and solder the IC's GND directly to the ground plane. Fig. 35 to 37 are the recommended layout diagrams.

Ripple Voltage Reduction

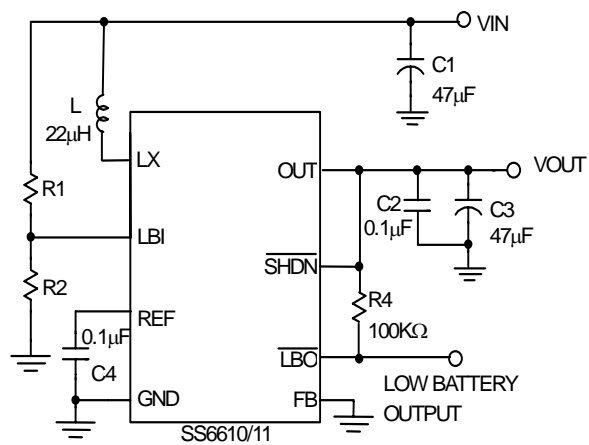
Two or three parallel output capacitors can significantly improve the output ripple voltage of the SS6610/11. The addition of an extra input ca-

pacitor results in a stable output voltage. Fig.38 shows the application circuit with the above features. Fig.39 to Fig.46 show the performance of Fig. 38.

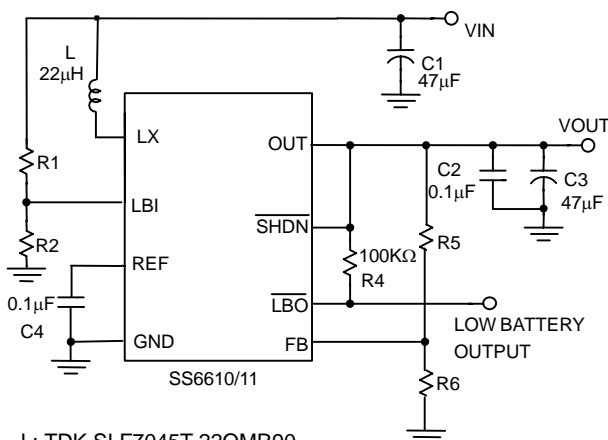
APPLICATION EXAMPLES



L: TDK SLF7045T-22OMR90
 C1, C3: NIPPON Tantalum Capacitor 6MCM476MB2TER
 Fig. 32. $V_{OUT} = 3.3V$ Application Circuit.



L: TDK SLF7045T-22OMR90
 C1, C3: NIPPON Tantalum Capacitor 6MCM476MB2TER
 Fig. 33. $V_{OUT} = 5.0V$ Application Circuit.



L: TDK SLF7045T-22OMR90
 C1, C3: NIPPON Tantalum Capacitor 6MCM476MB2TER
 $V_{OUT} = V_{REF} * (1 + R5/R6)$

Fig. 34 An Adjustable Output Application Circuit

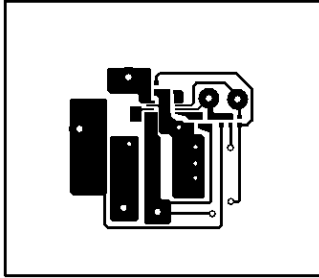


Fig. 35. Top layer

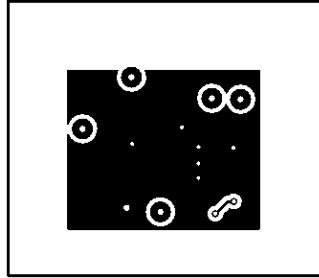


Fig. 36. Bottom layer

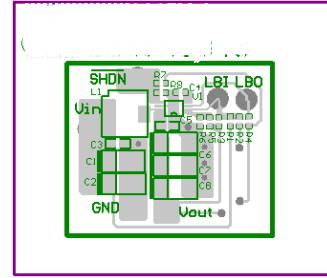
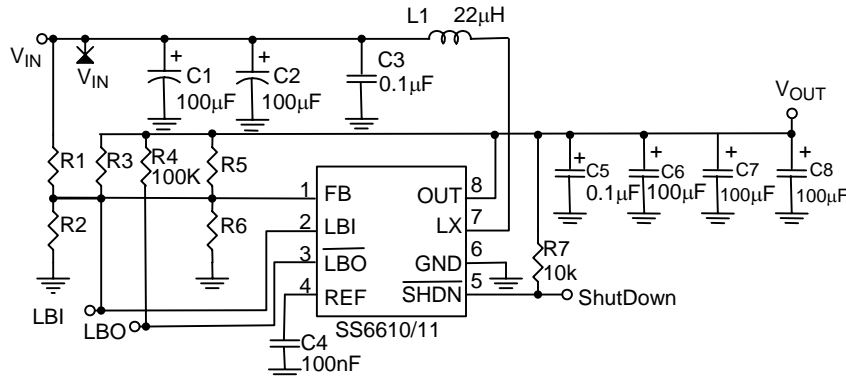


Fig. 37. Placement



R5=0Ω, R6=open; for $V_{OUT}=3.3V$
 R5=open, R6=0Ω; for $V_{OUT}=5.0V$
 $V_{OUT}=1.23(1+R5/R6)$; for adjustable output voltage
 L1: TDK SLF7045T-22OMR90
 C1~C2, C6~8: NIPPON Tantalum Capacitor 6MCM107MCTER

Fig. 38 SS6610/11 application circuit with small ripple voltage.

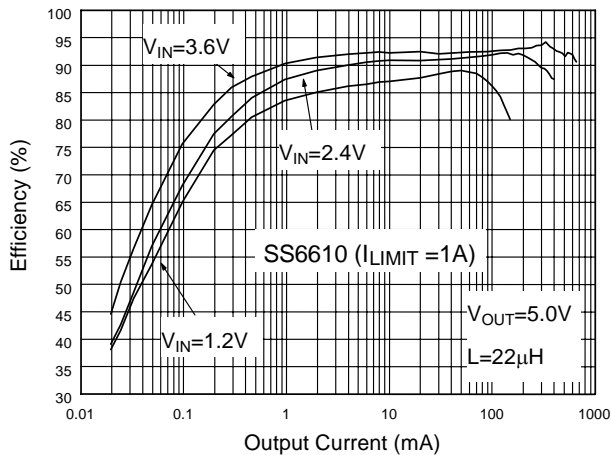


Fig. 39 Efficiency (ref. to Fig.38)

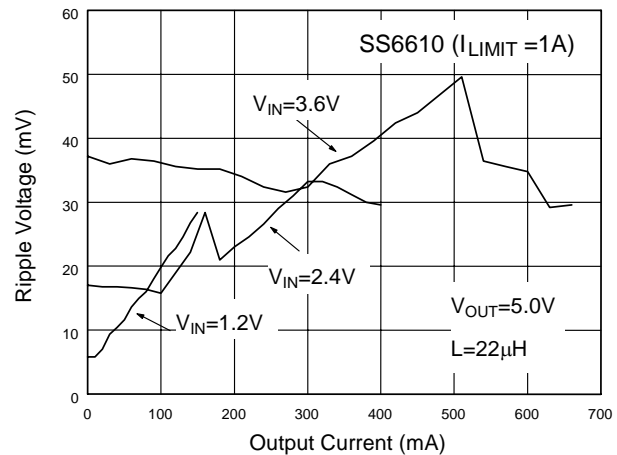
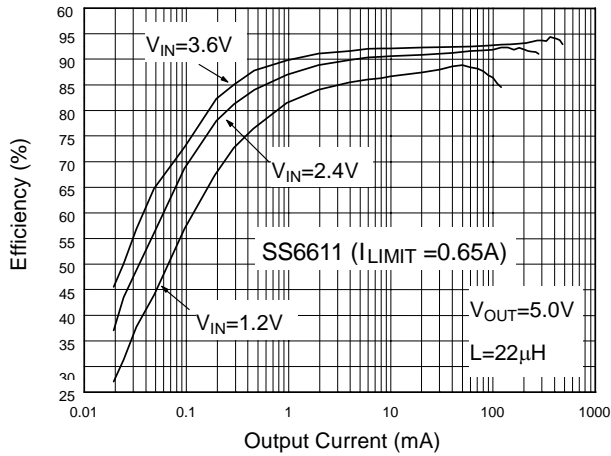
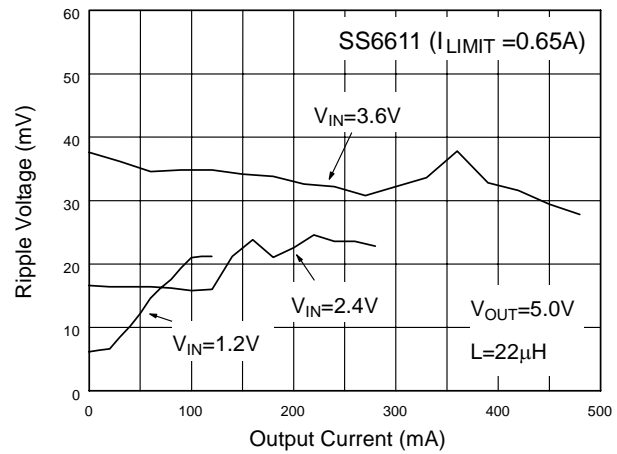
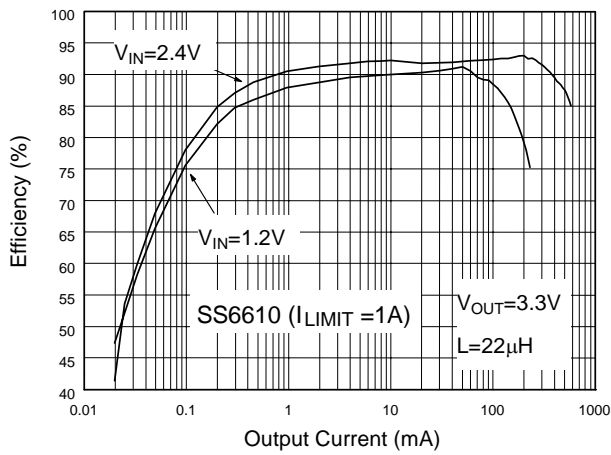
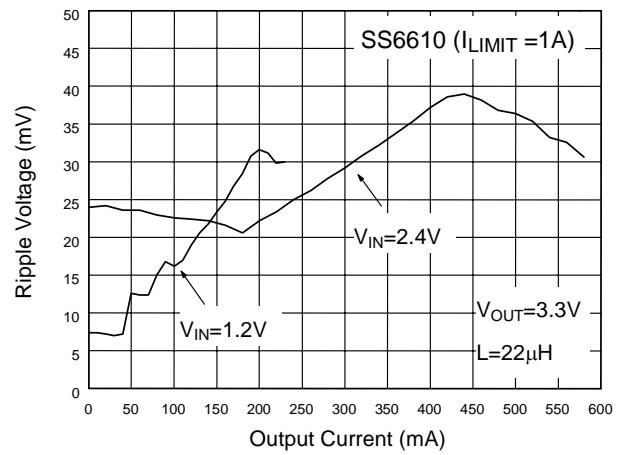
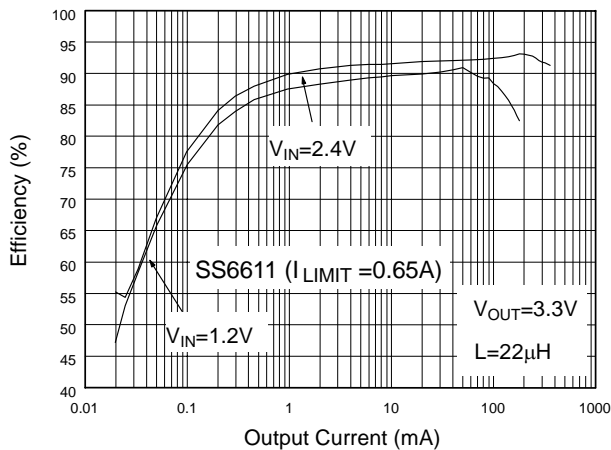
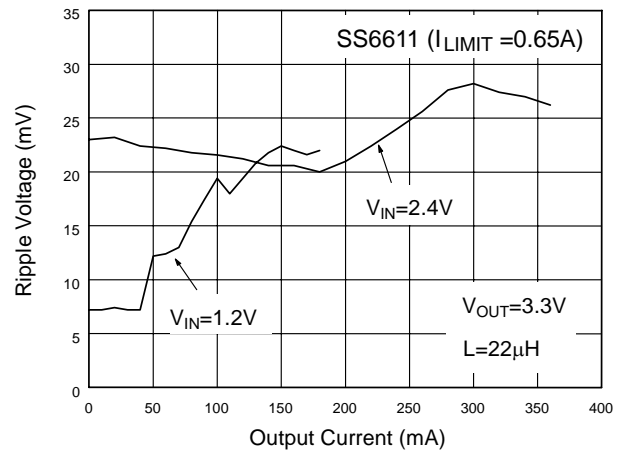
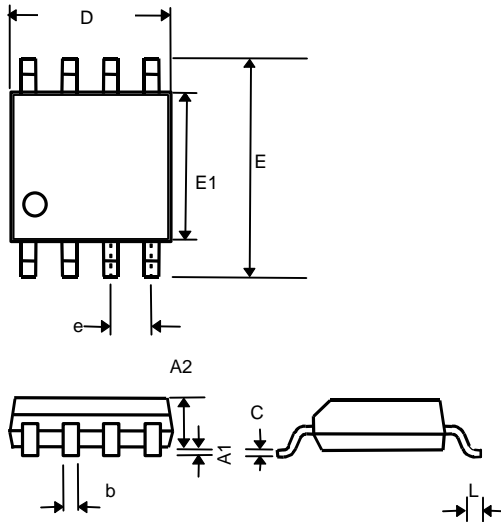


Fig. 40 Ripple Voltage (ref. to Fig.38)


Fig. 41 Efficiency (ref. to Fig.38)

Fig. 42 Ripple Voltage (ref. to Fig.38)

Fig. 43 Efficiency (ref. to Fig.38)

Fig. 44 Ripple Voltage (ref. to Fig.38)

Fig. 45 Efficiency (ref. to Fig.38)

Fig. 46 Ripple Voltage (ref. to Fig.38)

PHYSICAL DIMENSION
● 8 LEAD MSOP (unit: mm)


SYMBOL	MIN	MAX
A1	--	0.20
A2	0.76	0.97
b	0.28	0.38
C	0.13	0.23
D	2.90	3.10
E	4.80	5.00
E1	2.90	3.10
e	0.65	
L	0.40	0.66

Information furnished by Silicon Standard Corporation is believed to be accurate and reliable. However, Silicon Standard Corporation makes no guarantee or warranty, express or implied, as to the reliability, accuracy, timeliness or completeness of such information and assumes no responsibility for its use, or for infringement of any patent or other intellectual property rights of third parties that may result from its use. Silicon Standard reserves the right to make changes as it deems necessary to any products described herein for any reason, including without limitation enhancement in reliability, functionality or design. No license is granted, whether expressly or by implication, in relation to the use of any products described herein or to the use of any information provided herein, under any patent or other intellectual property rights of Silicon Standard Corporation or any third parties.