

High-Efficiency, Step-Down DC/DC Controller

FEATURES

- 4V to 18V input voltage operation.
- High-efficiency (up to 95%).
- Low quiescent current at 90 μ A.
- Pulse-skipping and pulse-frequency modulation.
- Inputs-uncommitted current-sense comparator.
- Duty-cycle adjustable.
- 90KHz to 280KHz oscillator frequency.
- Power-saving shutdown mode (8 μ A typical).
- Push-pull driver output.

APPLICATIONS

- Notebook 5V/3.3V Main Power
- Step-Down DC/DC Controller Modules.
- Constant-Current Source for Battery Chargers.

DESCRIPTION

The SS6578 is a high performance step-down DC/DC controller, designed to drive an external P-channel MOSFET to generate programmable output voltages. Two main schemes of Pulse-Skipping and Pulse-Frequency Modulation are employed to maintain low quiescent current and high conversion efficiency under wide ranges of input voltage and loading condition. The SS6578 delivers 10mA to 2A of output current with 87%~93% efficiency at $V_{IN}=9V$, $V_{OUT}=5V$ condition. A current-sense comparator with both inverting and non-inverting inputs uncommitted is included to provide the crucial function of either current-limit protection or constant-output current control. When the SS6578 is used in a high-side current-sensing step-down constant-current source, the efficiency is typically greater than 90%. Duty-cycle can be adjusted to greater than 90% by connecting a resistor from DUTY pin to V_{IN} . Quiescent current is about 90 μ A and can be reduced to 8 μ A in shutdown mode. The switching frequency range of around 90 kHz to 280 kHz allows small size switching components, which are ideal for battery powered portable equipment.

ORDERING INFORMATION

SS6578CXXX

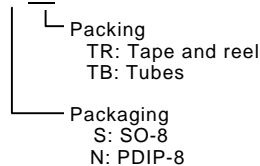

Example: SS6578CSTR

→ in SO-8 package, shipped in tape and reel packing

(PDIP-8 is only available in tubes)

PIN CONFIGURATION

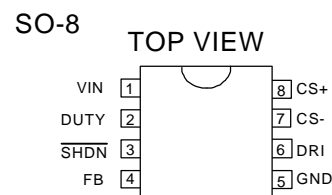

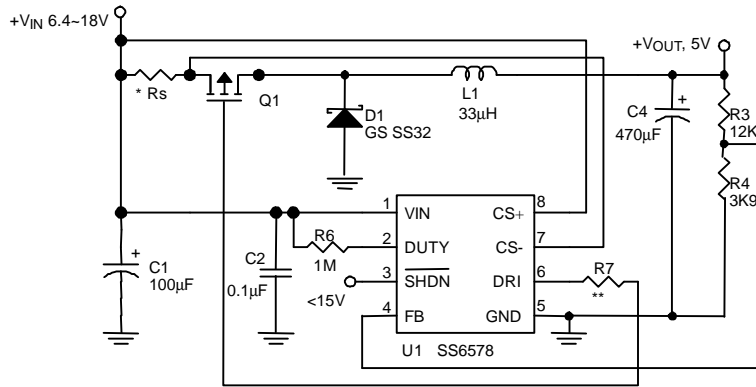
TYPICAL APPLICATION CIRCUIT

$$I_P = I_{O,MAX} + \frac{V_O(V_{IN} - V_O)}{2V_{IN} \times f_S \times L}$$

$$R_S = \frac{V_{TH}}{I_P} = \frac{50mV}{I_P} = \frac{0.1V_{IN}f_S L}{2V_{IN}f_S L I_{O,MAX} + V_{IN}V_O - V_O^2}$$

V_{IN} : Input voltage

V_{OUT} : Output voltage

f_S : Working frequency

L : Inductor value

$I_{O,MAX}$: Maximum Output current

V_{TH} : Current Limit Sense Threshold

** $V_{IN} > 15V$, $R7 = 15\Omega$

$V_{IN} \leq 15V$, $R7 = 0\Omega$

DC/DC Buck Converter
ABSOLUTE MAXIMUM RATINGS

V_{IN} Supply Voltage.....	20V
DUTY Voltage.....	20V
SHDN Voltage.....	15V
Operating Temperature Range.....	0°C~70°C
Storage Temperature Range.....	-65°C~ 150°C

TEST CIRCUIT

Refer to TYPICAL APPLICATION CIRCUIT.

ELECTRICAL CHARACTERISTICS

(VIN= 13V, TA=25°C, unless otherwise spe cified.)

PARAMETERS	CONDITIONS	MIN.	TYP.	MAX.	UNIT
Operation Voltage		4		20	V
Quiescent Current	$V_{FB} = 1.5V$		90	160	μA
Shutdown Mode Current	$V_{\overline{SHDN}} = 0V$		8	20	μA
Internal Reference Voltage		1.16	1.22	1.28	V
Driver Sinking "ON Resistance"			16		Ω
Driver Sourcing "ON Resistance"			11		Ω
Current Limit Sense Threshold	$V_{CS+} = 13V$	50	70	90	mV
Shutdown Threshold		0.8	1.5	2.4	V
\overline{SHDN} Pin Leakage Current	$V_{\overline{SHDN}} < 15V$			1	μA
Duty Cycle	$V_{DUTY} = V_{IN}$		71		%
Oscillator Frequency	$V_{DUTY} = V_{IN}$		225		KHz

TYPICAL PERFORMANCE CHARACTERISTICS

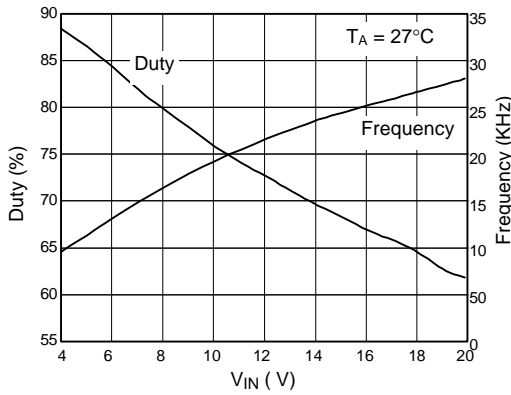

Fig. 1 Frequency & Duty Cycle vs. V_{IN}

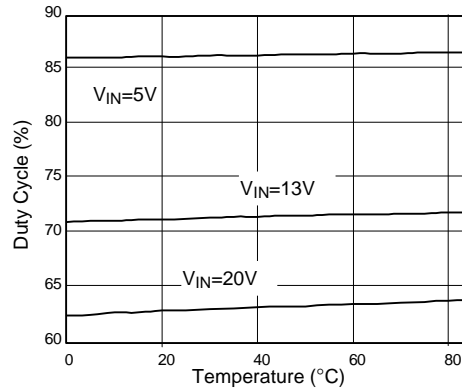

Fig. 2 Duty Cycle vs. Temperature

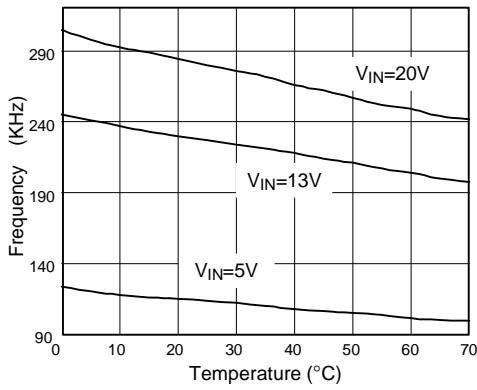

Fig. 3 Frequency vs. Temperature

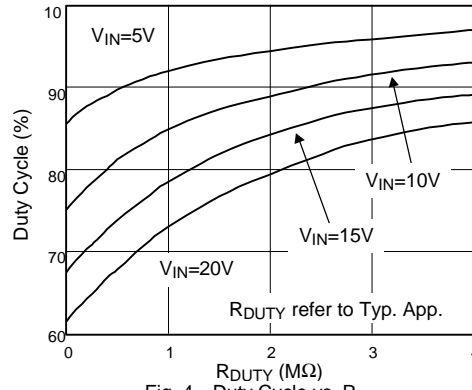

Fig. 4 Duty Cycle vs. R_{DUTY}

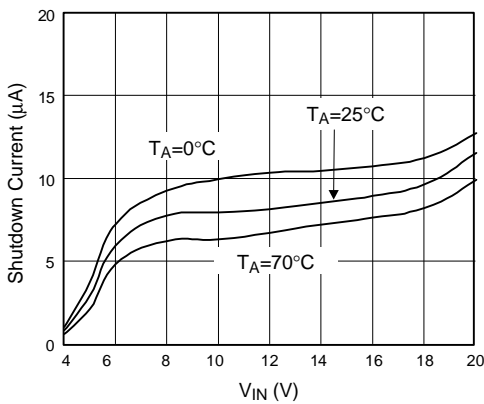

Fig. 5 Shutdown Current vs. V_{IN}

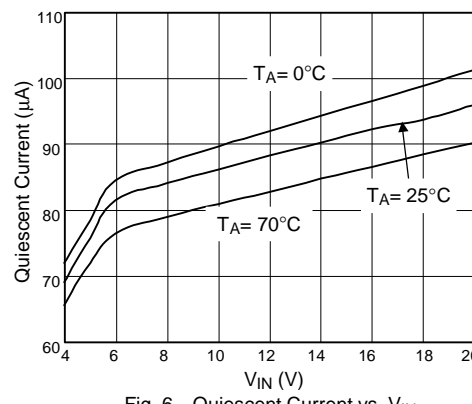
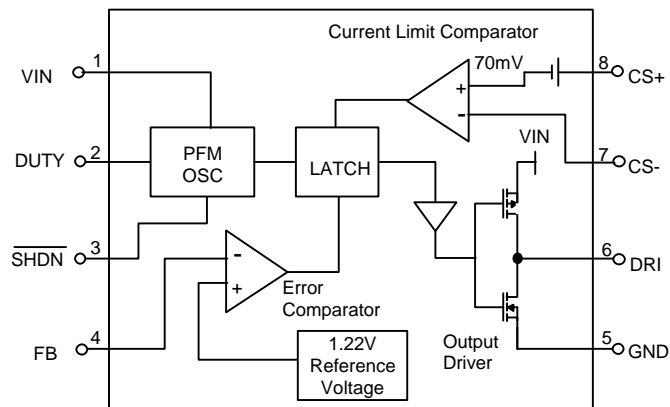

Fig. 6 Quiescent Current vs. V_{IN}

BLOCK DIAGRAM



PIN DESCRIPTIONS

- PIN 1: VIN - Input supply voltage - a range of 4V to 18V is recommended.
- PIN 2: DUTY - Duty cycle adjustment pin. To be tied to the VIN pin directly or through a resistor R_{DUTY} to adjust oscillator duty cycle. R_{DUTY} must be over $1M\Omega$ if $V_{IN}=20V$. See TYPICAL PERFORMANCE CHARACTERISTICS.
- PIN 3: \overline{SHDN} - Logical input to shutdown the chip:
 $V_{\overline{SHDN}} = \text{High}$ for normal operation.
 $V_{\overline{SHDN}} = \text{Low}$ for shutdown.
 This pin should not be floating or be forced to over 15V. In shutdown mode DRI pin is held high.
- PIN 4: FB - Feedback comparator input, to compare the feedback voltage with the internal reference voltage.

Connecting a resistor R1 to converter output node and a resistor R2 to ground yields the output voltage:

$$V_{OUT} = 1.22 \times (R1 + R2) / R2$$

- PIN 5: GND - Power ground.
- PIN 6: DRI - Push-pull driver output to drive an external P-channel MOSFET or PNP transistor. When driving a PNP bipolar transistor, a base resistor and a capacitor to the base of PNP are recommended.
- PIN 7: CS- - Current-sense comparator inverting input. This pin voltage should go over 2V but should not exceed VIN voltage.
- PIN 8: CS+ - Current sense comparator non-inverting input. This pin voltage should go over 2V but should not exceed VIN voltage.

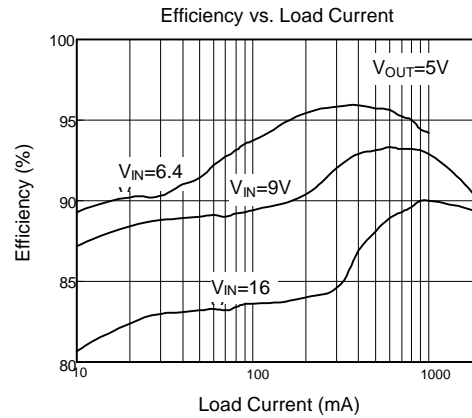
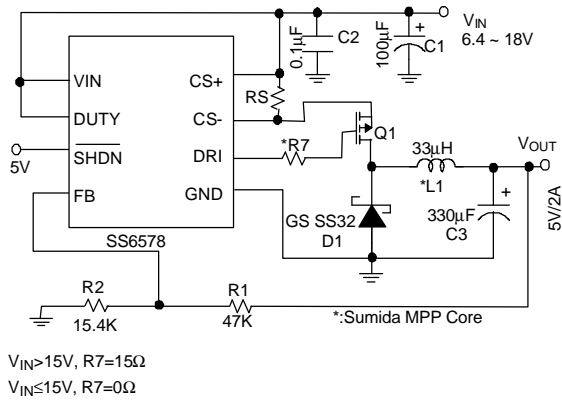
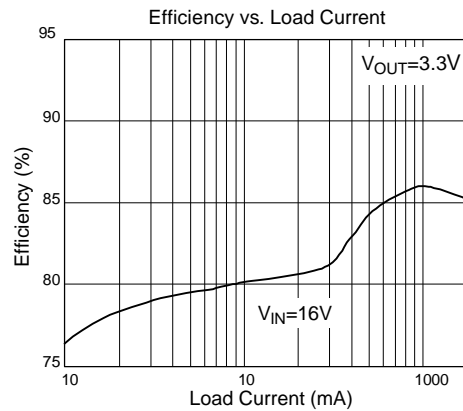
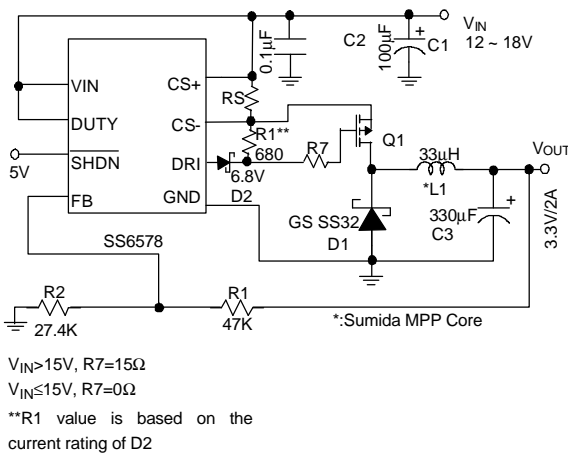
APPLICATION EXAMPLES

Fig. 7 5V Step-Down Converter

Fig. 8 3.3V Step-Down Converter

APPLICATION INFORMATION

A. Start Up Design

In order to eliminate the over-shoot issue which happens when V_{OUT} is under 5V, we offer two solutions for the SS6578 as a buck controller.

1. Buck Converter with $12V < V_{IN} < 18V$

When the SS6578 is used in a Buck Circuit with $V_{OUT} < 5V$, add a resistor R1 of 680 ohm and a Zener diode D2 of 6.8V.

This solution will limit the temperature rise of MOSFET Q1. The smaller the resistor value, the lower temperature rise. The resistor value is determined by the reverse current rating of the Zener diode. Refer to its databook for the reverse current rating. Note that the current is strictly limited by the spec.

A temperature rise of $1^{\circ}C$ for Q1 results from the addition of $R1=680\text{ohm}$, $D2=6.8V$ to the original condition ($V_{IN}=12V$, $V_{OUT}=3.3V$ and $I_{OUT}=1.5A$). Yet, the efficiency of the system remains nearly

the same.

Note: The input voltage rating in this circuit is 12V rather than 4V, and the rating can be varied depending on the value of Zener diode D2. Please refer to Fig3.

The current-sense resistor R_s is used for over-current protection. Due to concerns about the power loss, cost, and size, many users do not use R_s in their buck converter application. Damage caused by unexpected current (over rating current) could be done to Q1, U1 and the circuits attached to V_{OUT} when R_s is not used. For the calculation of R_s , please refer to the formula of R_s in "Typical Application" above.

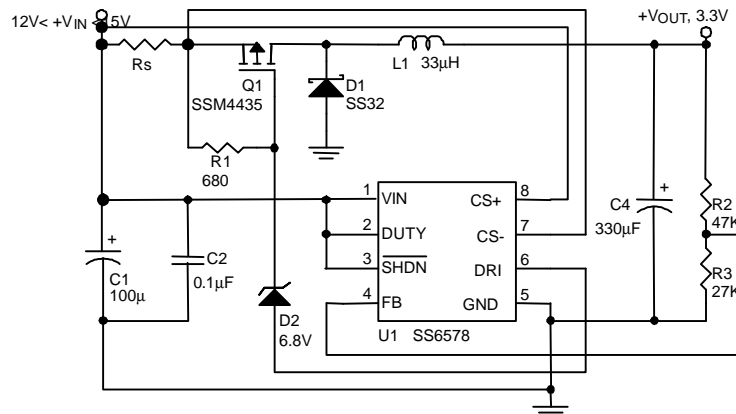
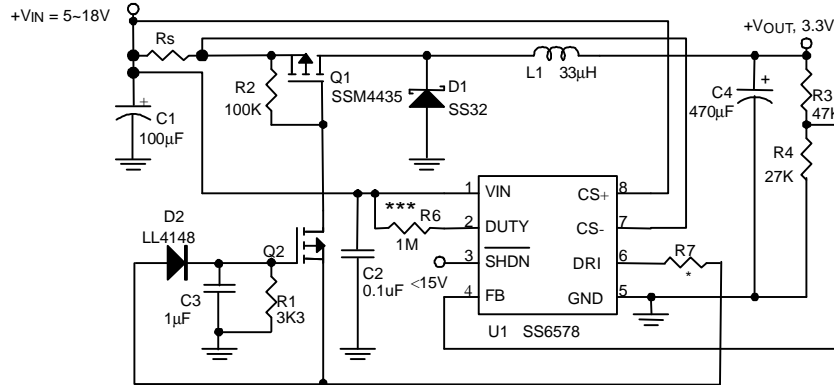

Fig. 10 DC/DC Buck Converter $V_{OUT}=3.3V$



* $V_{IN} > 15V$, $R7 = 15\Omega$
 $V_{IN} \leq 15V$, $R7 = 0\Omega$ *

*** $R6$ can adjust the duty cycle max. It can be 0Ω

Fig 11. DC/DC Buck Converter $V_{OUT} = 3.3V$

B. Short Circuit Protection Design

1. As we know, Short Circuit Protection (abbreviated as SCP) does not always exist in the DC-DC converter circuit. The fact is usually the DC-DC converter provides the circuits attached to V_{OUT} with low power or low voltage. Sometimes there is less concern about safety, as the probability of short-circuit is quite low. That gives users reasons to ignore the use of an SCP circuit. However, we would still like to point out the importance of the protection. With SCP, the system will be well protected in any situation. Two SCP circuits are introduced as follows for your reference.
2. Design1: shown as Fig. 12.
 Method: Add a fast fuse to V_{OUT} .

A fuse can be selected to pass the start up current, but open quickly with a large unexpected current. Of course, replacement of the fuse is needed after short circuit.

3. Design 2: shown as Fig. 13.
 Method: Add a SCP circuit
 Note: 1. The time constant, which is directly related to $R1$ and $C1$, has a serious effect on the circuit.
 2. Circuit can be recovered by removing the short circuit event from the system.
 3. The condition for applying this design is $V_{OUT} \geq 3V$.

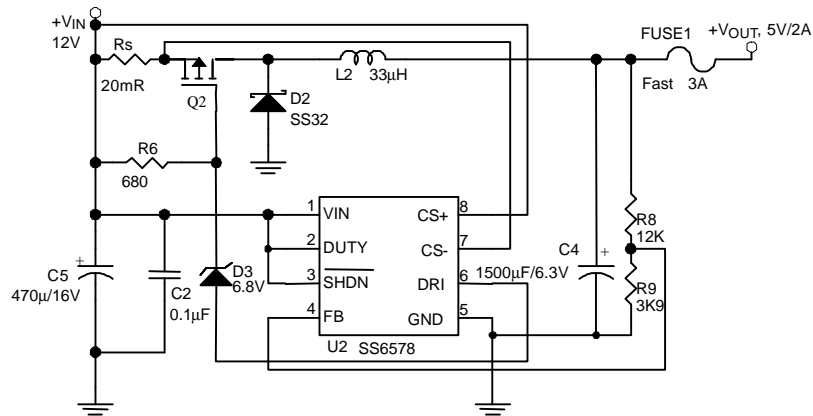

Fig 12. Add a Fast Fuse Solution

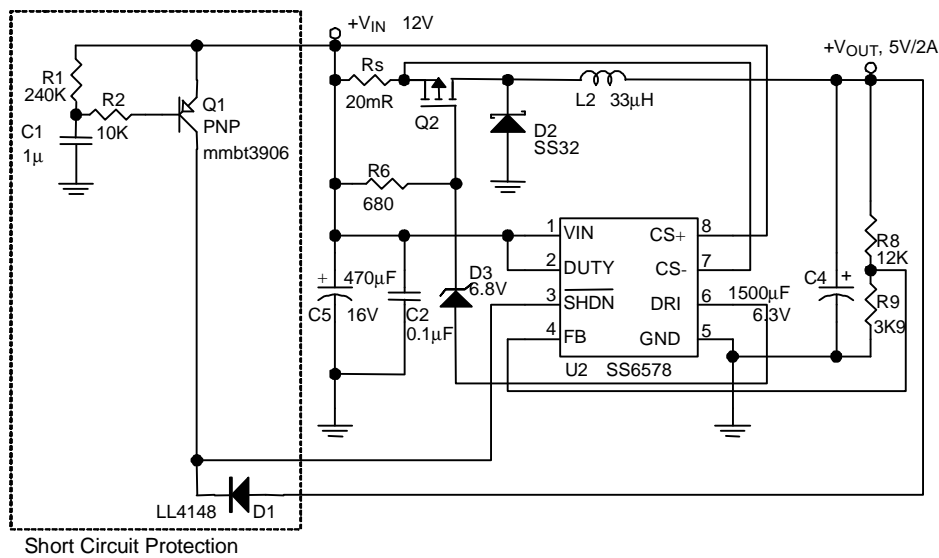
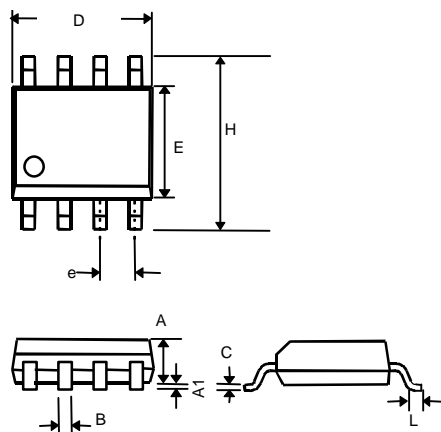
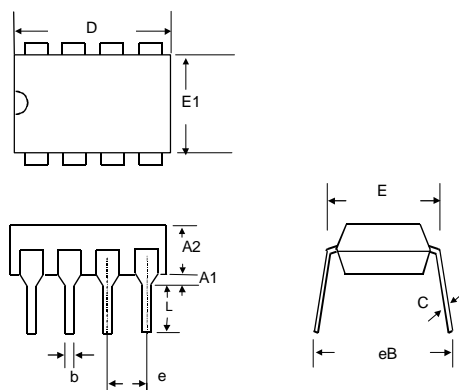

Fig 13. Add A Short Circuit Protection Circuit Solution

PHYSICAL DIMENSIONS
8 LEAD PLASTIC SO (unit: mm)

SYMBOL	MIN	MAX
A	1.35	1.75
A1	0.10	0.25
B	0.33	0.51
C	0.19	0.25
D	4.80	5.00
E	3.80	4.00
e	1.27(TYP)	
H	5.80	6.20
L	0.40	1.27

8 LEAD PLASTIC DIP (unit: mm)

SYMBOL	MIN	MAX
A1	0.381	—
A2	2.92	4.96
b	0.35	0.56
C	0.20	0.36
D	9.01	10.16
E	7.62	8.26
E1	6.09	7.12
e	2.54 (TYP)	
eB	—	10.92
L	2.92	3.81

Information furnished by Silicon Standard Corporation is believed to be accurate and reliable. However, Silicon Standard Corporation makes no guarantee or warranty, express or implied, as to the reliability, accuracy, timeliness or completeness of such information and assumes no responsibility for its use, or for infringement of any patent or other intellectual property rights of third parties that may result from its use. Silicon Standard reserves the right to make changes as it deems necessary to any products described herein for any reason, including without limitation enhancement in reliability, functionality or design. No license is granted, whether expressly or by implication, in relation to the use of any products described herein or to the use of any information provided herein, under any patent or other intellectual property rights of Silicon Standard Corporation or any third parties.