

SDP8304/8314

Optoschmitt Detector Open-Collector Output

FEATURES

- Side-looking plastic package
- 55° (nominal) acceptance angle
- TTL/LSTTL/CMOS compatible
- Open collector output
- Buffer (SDP8304) or inverting (SDP8314) logic available
- High noise immunity output
- Mechanically and spectrally matched to SEP8506 and SEP8706 infrared emitting diodes

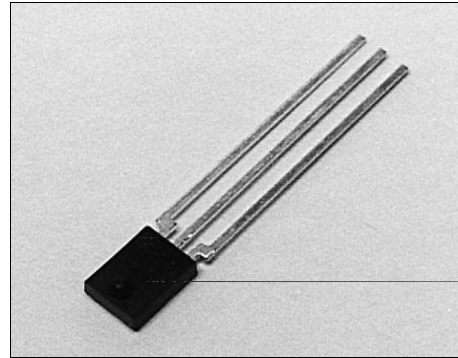

INFRA-8.TIF

DESCRIPTION

The SDP8304/8314 series consists of a high speed IC molded in a side-looking black plastic package to minimize the effect of visible ambient light. The detector incorporates a Schmitt trigger which provides pulse shaping and hysteresis for noise immunity. Output rise and fall times are independent of rate of change of incident light. Detector sensitivity has been internally temperature compensated. The output stage is an open collector NPN transistor. This configuration allows the sensor to interface with circuit elements driven by supply voltages other than the V_{CC} supply. For additional output configuration options refer to SDP8004/8014 and SDP8604/8614.

Device Polarity:

- Buffer - Output is HI when incident light intensity is above the turn-on threshold level.
- Inverter - Output is LO when incident light intensity is above the turn-on threshold level.

OUTLINE DIMENSIONS in inches (mm)

Tolerance	3 plc decimals	±0.005(0.12)
	2 plc decimals	±0.020(0.51)

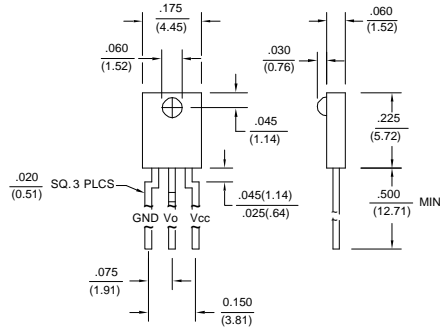

DIM_026.d54

SDP8304/8314

Optoschmitt Detector
Open-Collector Output

ELECTRICAL CHARACTERISTICS (-40°C to +85°C unless otherwise noted)

PARAMETER	SYMBOL	MIN	TYP	MAX	UNITS	TEST CONDITIONS
Operating Supply Voltage	V _{CC}	4.5		12.0	V	T _A =25°C
Turn-on Threshold Irradiance ⁽²⁾ SDP8304-301, SDP8314-301	E _{ET(+)}	0.06		0.37	mW/cm ²	V _{CC} =5 V T _A =25°C
Hysteresis ⁽³⁾	HYST	33		67	%	
Supply Current	I _{CC}			15.0	mA	V _{CC} =12 V E _e =0 Or 3.0 mW/cm ²
Low Level Output Voltage SDP8304 SDP8314	V _{OL}			0.4 0.4	V	V _{CC} =5 V, I _{OL} =12.8 mA E _e =0 E _e =3.0 mW/cm ²
High Level Output Current SDP8304 SDP8314	I _{OH}			100 100	μA	V _{CC} =4.5 V V _{OH} =30 V E _e =3.0 mW/cm ² E _e =0
Operate Point Temperature Coefficient			-0.76		%/°C	Emitter @ Constant Temperature
Output Rise Time, Output Fall Time	t _r , t _f		7.0		ns	V _{CC} =5 V, T _A =25°C E _e =0 or 3.0 mW/cm ² f=10.0 kHz, D.C.=50% R _L =390 Ω
Propagation Delay, Low-High, High-Low	t _{PLH} , t _{PHL}		2.5	5.0	μs	V _{CC} =5 V, T _A =25°C E _e =0.5 mW/cm ² f=10.0 kHz, D.C.=50% R _L =390 Ω
Clock Frequency				100	kHz	R _L =390 Ω, C _L =50 pF

Notes

1. It is recommended that a bypass capacitor, 0.1 μF typical, be added between V_{CC} and GND near the device in order to stabilize power supply line.
2. The radiation source is an IRED with a peak wavelength of 935 nm.
3. Hysteresis is defined as the difference between the operating and release threshold intensities, expressed as a percentage of the operate threshold intensity.

ABSOLUTE MAXIMUM RATINGS

(25°C Free-Air Temperature unless otherwise noted)

Supply Voltage	12 V ⁽¹⁾
Duration of Output Short to V _{CC} or Ground	1.0 sec
Applied Output Voltage	35 V
Low Level Output Current	16 mA
Irradiance	25 mW/cm ²
Operating Temperature Range	-40°C to 85°C
Storage Temperature Range	-40°C to 85°C
Soldering Temperature (5 sec)	240°C

Notes

1. Derate linearly from 25°C to 5.5 V at 85°C.

SCHEMATIC SDP8304 BUFFER, OPEN-COLLECTOR

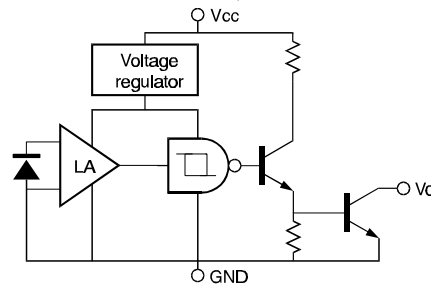

Honeywell reserves the right to make changes in order to improve design and supply the best products possible.

Honeywell

189

SDP8304/8314

Optoschmitt Detector
Open-Collector Output

SCHEMATIC

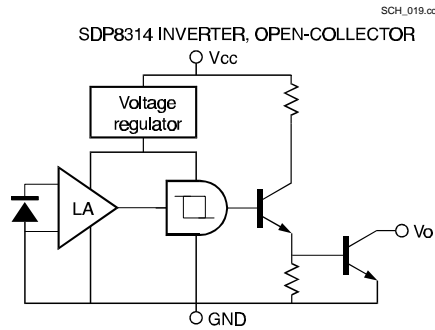

SWITCHING TIME TEST CIRCUIT

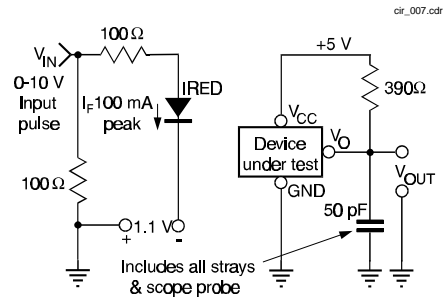

SWITCHING WAVEFORM FOR BUFFERS

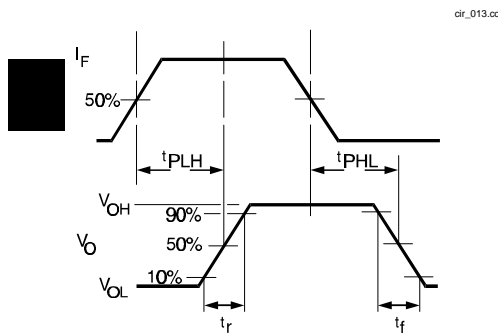

SWITCHING WAVEFORM FOR INVERTERS

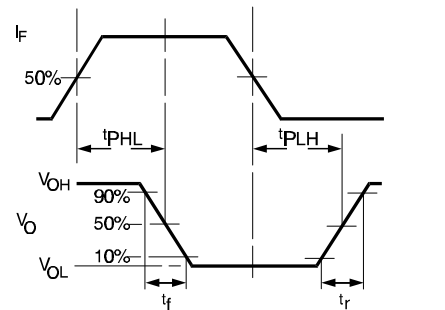

Fig. 1 Responsivity vs Angular Displacement

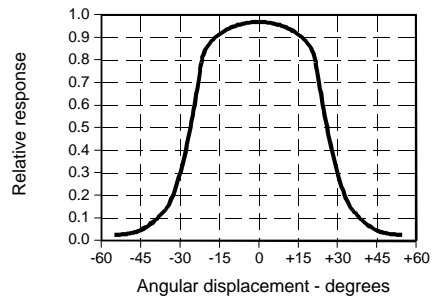
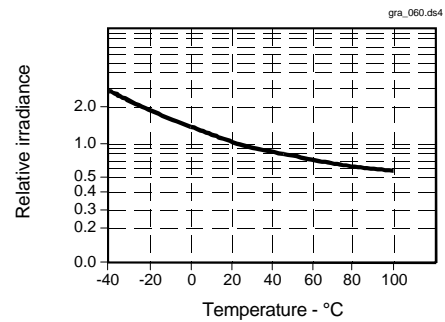

Fig. 2 Threshold Irradiance vs Temperature



SDP8304/8314

Optoschmitt Detector

Open-Collector Output

Fig. 3 Output Rise Time (t_r) and Output Fall Time (t_f) vs Temperature

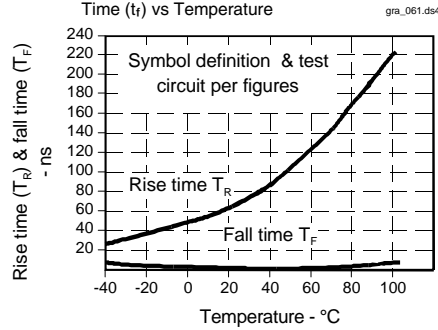

Fig. 4 Delay Time vs Temperature

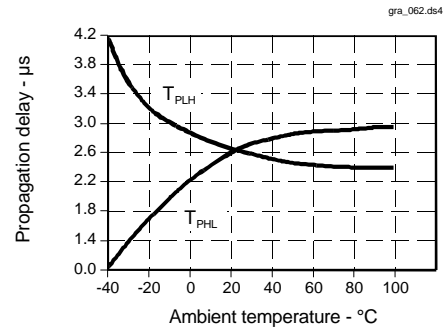
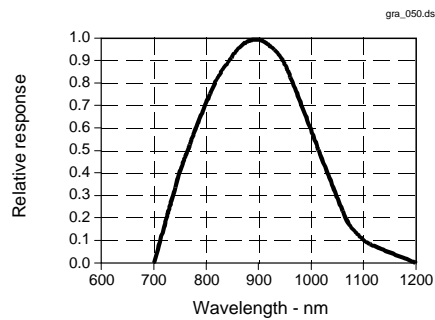

Fig. 5 Spectral Responsivity



All Performance Curves Show Typical Values

Honeywell reserves the right to make changes in order to improve design and supply the best products possible.

Honeywell