

DELPHI SERIES



FEATURES

- Efficiency up to 80%
- Industry standard form factor and pinout
- Size: 15.24x8.0x6.8mm (0.60"x0.31"x0.27")
- Input: 5V, 12V, 24V ($\pm 10\%$)
- Output: ± 5 , ± 9 , ± 12 , ± 15 V
- Low ripple and noise
- 1000V isolation
- SMD packaged
- Moisture sensitivity level (MSL) 3
- UL 94V-0 Package Material
- ISO 9001 and ISO 14001 certified manufacturing facility

Delphi DSAU200 Series DC/DC Power Modules: 5, 12, 24Vin, 1W SMD

The Delphi DSAU200, 5V, 12V, and 24V input, dual output, SMD form factor, isolated DC/DC converter is the latest offering from a world leader in power systems technology and manufacturing — Delta Electronics, Inc. The DSAU200 series operate from 5V, 12V, or 24V ($\pm 10\%$) and provides ± 5 V, ± 9 V, ± 12 V, or ± 15 V of dual output in an industrial standard, plastic molded SMD package. This series provides up to 1W of output power with 1000V isolation and a typical full-load efficiency up to 80%. With creative design technology and optimization of component placement, these converters possess outstanding electrical and thermal performance, as well as extremely high reliability under highly stressful operating conditions.

OPTIONS

APPLICATIONS

- Industrial
- Transportation
- Process/ Automation

DATASHEET
DS_DSAU200_12032008

Delta Electronics, Inc.

TECHNICAL SPECIFICATIONS

T_A = 25°C, airflow rate = 0 LFM, nominal Vin, nominal Vout, resistive load unless otherwise noted.

PARAMETER	NOTES and CONDITIONS	DSAU200 (Standard)			
		Min.	Typ.	Max.	Units
ABSOLUTE MAXIMUM RATINGS					
Input Voltage					
Transient	5V input model, 1000ms	-0.7		9	Vdc
Transient	12V input model, 1000ms	-0.7		18	Vdc
Transient	24V input model, 1000ms	-0.7		30	
Internal Power Dissipation				450	mW
Operating Temperature	Ambient	-40		85	°C
	Case	-40		100	°C
Storage Temperature		-40		125	°C
Humidity				95	%
Lead Temperature in Assembly	1.5mm from case for 10 seconds			260	°C
Input/Output Isolation Voltage		1000			Vdc
INPUT CHARACTERISTICS					
Operating Input Voltage	5V input model	4.5	5	5.5	Vdc
	12V input model	10.8	12	13.2	Vdc
	24V input model	21.6	24	26.4	Vdc
Maximum Input Current	Please see Model List table on page 6				
No-Load Input Current	5V model		30		mA
	12V model		15		mA
	24V model		9		mA
Reverse Polarity Input Current				0.3	A
OUTPUT CHARACTERISTICS					
Output Voltage Set Point Accuracy			±1.0	±3.0	%
Output Voltage Balance	Dual output models		±0.1	±1.0	%
Output Voltage Regulation					
Over Load	Io=20% to 100%, please see page 6				
Over Line	For Vin change of 1%				
Over Temperature	Tc=-40°C to 100°C				
Output Voltage Ripple and Noise	5Hz to 20MHz bandwidth				
Peak-to-Peak	Full Load, 0.33µF ceramic				
Peak-to-Peak, over line, load, temperature	Full Load, 0.33µF ceramic				
RMS	Full Load, 0.33µF ceramic				
Output Short Circuit				0.5	Second
Maximum Output Capacitance	Dual output models, each output			33	µF
EFFICIENCY					
100% Load	Please see Model List table on page 6				
ISOLATION CHARACTERISTICS					
Isolation Voltage	Input to output, 60 Seconds	1000			Vdc
Isolation Voltage Test	Flash Test for 1 seconds	1100			Vdc
Isolation Resistance	500VDC	1000			MΩ
Isolation Capacitance	100KHz, 1V		40	100	pF
FEATURE CHARACTERISTICS					
Switching Frequency		50	100	140	kHz
GENERAL SPECIFICATIONS					
MTBF	MIL-HDBK-217F; Ta=25°C, Ground Benign	2			M hours
Weight	5V and 12V models		1.8		grams
	24V models		2.2		grams
Case Material	Non-conductive black plastic				
Flammability	UL94V-0				
Input Fuse	5V model, 500mA slow blown type				
	12V model, 200mA slow blown type				
	24V model, 100mA slow blown type				

Notes:

1. These power converters require a minimum output load to maintain specified regulation (please see page 6 for the suggested minimum load). Operation under no-load conditions will not damage these modules; however, they may not meet all specifications listed above.
2. These DC/DC converters should be externally fused at the front end for protection.



ELECTRICAL CHARACTERISTICS CURVES

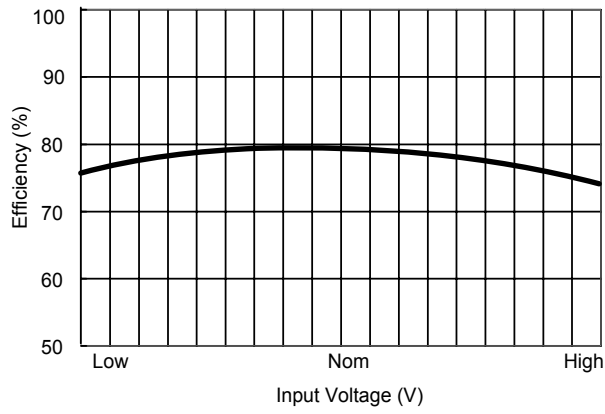

Figure 1: Efficiency vs. Input Voltage

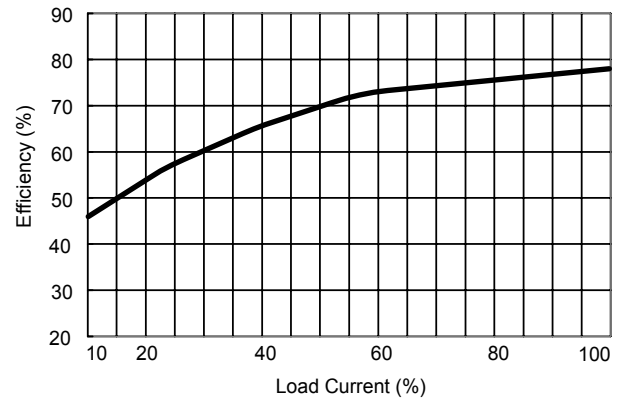

Figure 2: Efficiency vs. Output Load

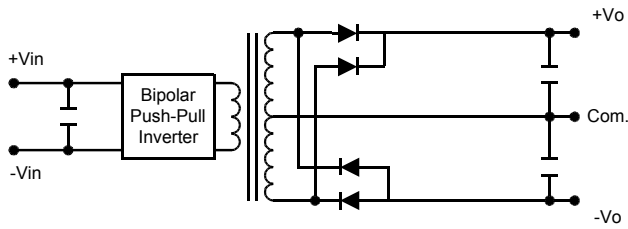

Figure 3: Block diagram of DSAU200

Design & Feature Considerations

The DSAU200 circuit block diagrams are shown in Figure 3.

Peak-to-Peak Output Noise Measurement

Scope measurement should be made by using a BNC socket, measurement bandwidth is 0-20 MHz. Position the load between 50 mm and 75 mm from the DC/DC Converter. A C_{out} of 0.33 μ F ceramic capacitor is placed between the terminals shown below.

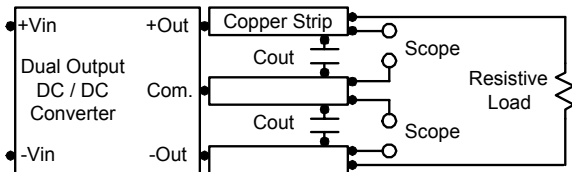

Input Source Impedance

The power module should be connected to a low ac-impedance input source. Highly inductive source impedances can affect the stability of the power module.

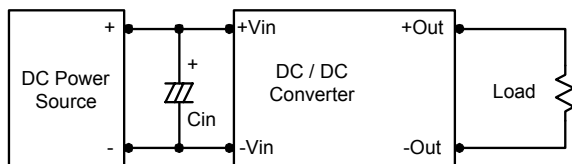

In applications where power is supplied over long lines and output loading is high, it may be necessary to use a capacitor at the input to ensure startup.

Capacitor mounted close to the input of the power module helps ensure stability of the unit, it is recommended to use a good quality low Equivalent Series Resistance ($ESR < 1.0\Omega$ at 100 KHz) capacitor of a 2.2 μ F for the 5V input devices, a 1.0 μ F for the 12V input devices, and a 0.47 μ F for the 24V devices.

Maximum Capacitive Load

The DSAU200 series has limitation of maximum connected capacitance at the output. The power module may be operated in current limiting mode during start-up, affecting the ramp-up and the startup time. For optimum performance we recommend 33 μ F maximum capacitive load for dual outputs.

Output Ripple Reduction

A good quality low ESR capacitor placed as close as practicable across the load will give the best ripple and noise performance.

To reduce output ripple, it is recommended to use 0.47 μ F capacitors at the output.

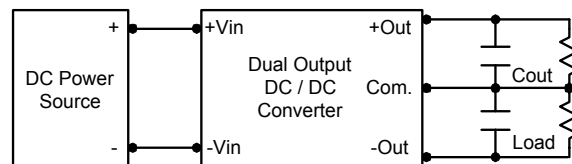

Soldering and Cleaning Considerations

Post solder cleaning is usually the final board assembly process before the board or system undergoes electrical testing. Inadequate cleaning and/or drying may lower the reliability of a power module and severely affect the finished circuit board assembly test. Adequate cleaning and/or drying is especially important for un-encapsulated and/or open frame type power modules. For assistance on appropriate soldering and cleaning procedures, please contact Delta's technical support team.



THERMAL CONSIDERATIONS

Thermal management is an important part of the system design. To ensure proper, reliable operation, sufficient cooling of the power module is needed over the entire temperature range of the module. Convection cooling is usually the dominant mode of heat transfer.

Hence, the choice of equipment to characterize the thermal performance of the power module is a wind tunnel.

Thermal Testing Setup

Delta's DC/DC power modules are characterized in heated vertical wind tunnels that simulate the thermal environments encountered in most electronics equipment. This type of equipment commonly uses vertically mounted circuit cards in cabinet racks in which the power modules are mounted.

The following figure shows the wind tunnel characterization setup. The power module is mounted on a test PWB and is vertically positioned within the wind tunnel. The space between the facing PWB and PWB is constantly kept at 25.4mm (1").

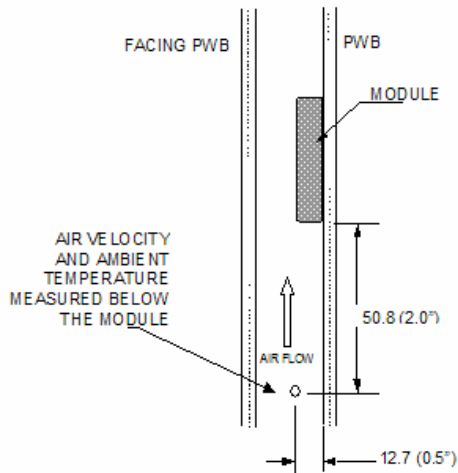

Note: Wind Tunnel Test Setup Figure Dimensions are in millimeters and (Inches)

Figure 4: Wind tunnel test setup

Thermal Derating

Heat can be removed by increasing airflow over the module. To enhance system reliability, the power module should always be operated below the maximum operating temperature. If the temperature exceeds the maximum module temperature, reliability of the unit may be affected.

THERMAL CURVES

DSAU200series Output Current vs. Ambient Temperature and Air Velocity (Either Orientation)

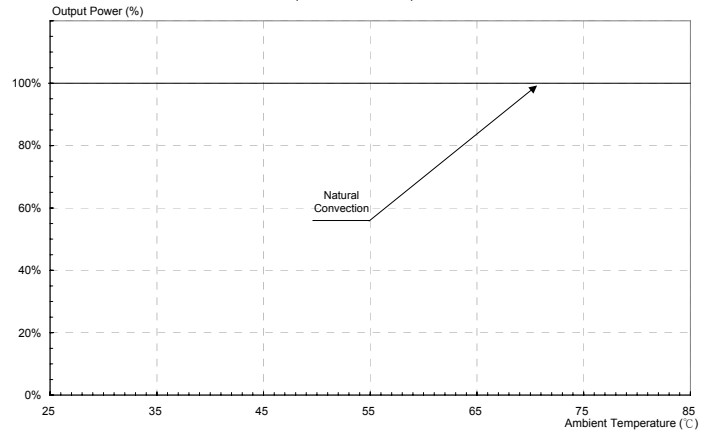

Figure 5: Derating Curve



MODEL LIST

	INPUT		OUTPUT			Full Load Efficiency	Load Regulation
	Vdc (V)	Max (mA)	Vdc (V)	Max (mA)	Min (mA)	%	%
DSAU201	5 (4.5 ~ 5.5)	267	±5	±100	±2	75	10
DSAU202		260	±9	±55	±1	76	10
DSAU203		255	±12	±42	±0.8	79	8
DSAU204		251	±15	±33	±0.7	79	7
DSAU211	12 (10.8 ~ 13.2)	111	±5	±100	±2	75	8
DSAU212		109	±9	±55	±1	76	8
DSAU213		105	±12	±42	±0.8	80	5
DSAU214		103	±15	±33	±0.7	80	5
DSAU221	24 (21.6 ~ 26.4)	56	±5	±100	±2	74	8
DSAU222		55	±9	±55	±1	75	8
DSAU223		53	±12	±42	±0.8	79	5
DSAU224		52	±15	±33	±0.7	79	5



PACKAGE: TAPE & REEL (5V/12V)



Packaging Specifications

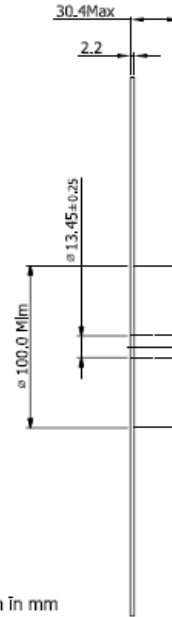
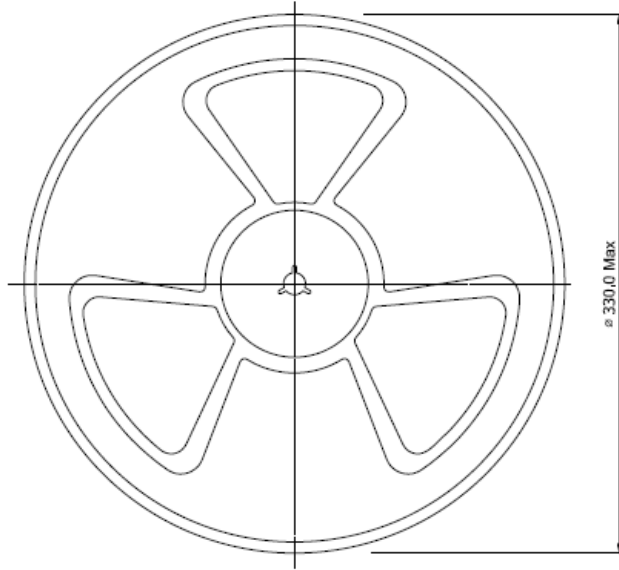

All dimension in mm

Tape

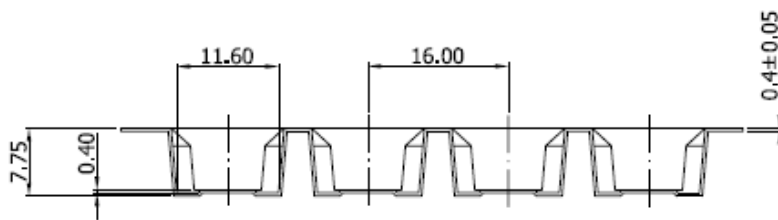
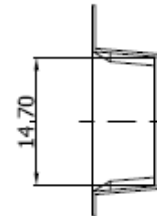
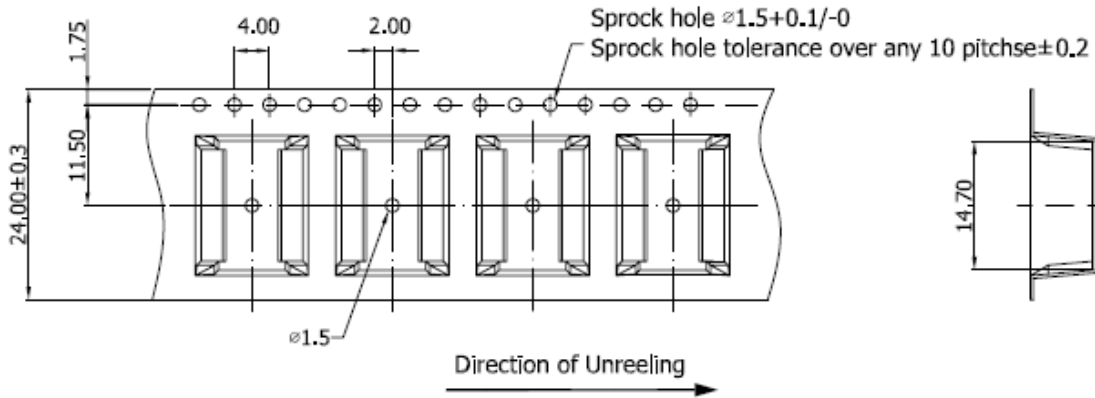

All dimension in mm
xx.xx ± 0.1



PACKAGE: TAPE & REEL (24V)



Packaging Specifications

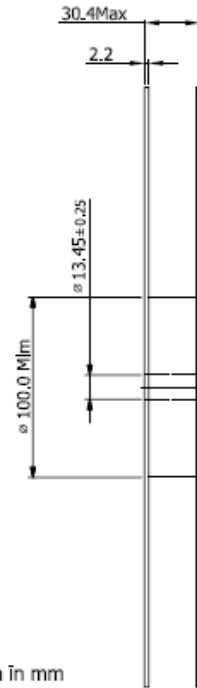
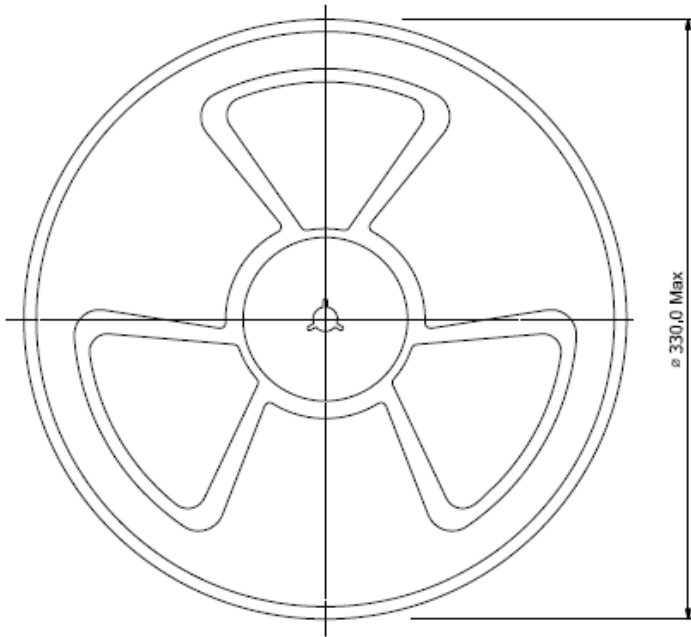

All dimension in mm

Tape

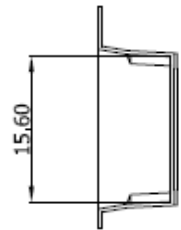
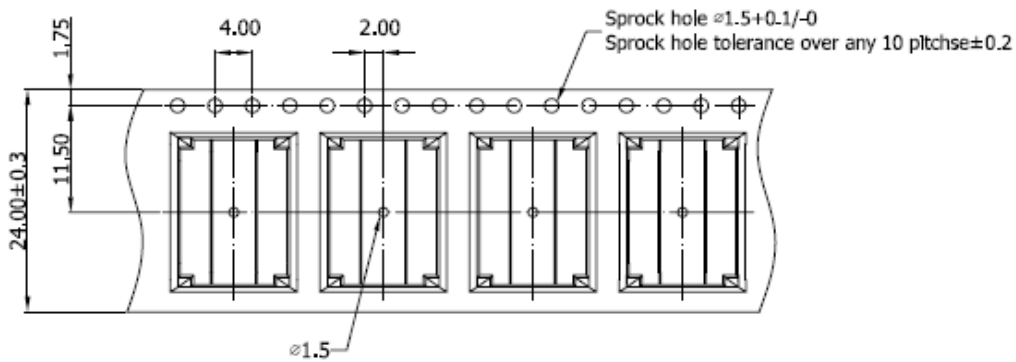

Direction of Unreeling →

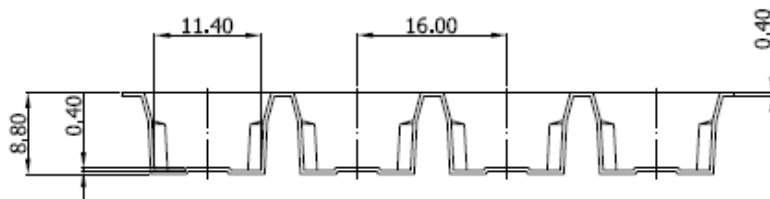

All dimension in mm
xx.xx±0.1

MECHANICAL DRAWING

(5V/12V)

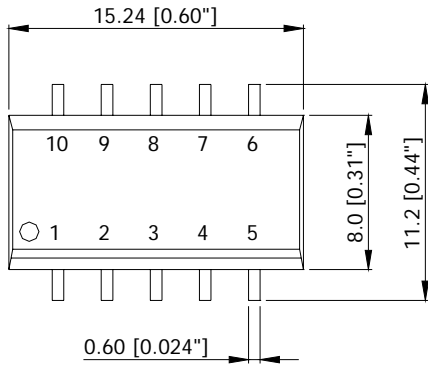

TOP VIEW

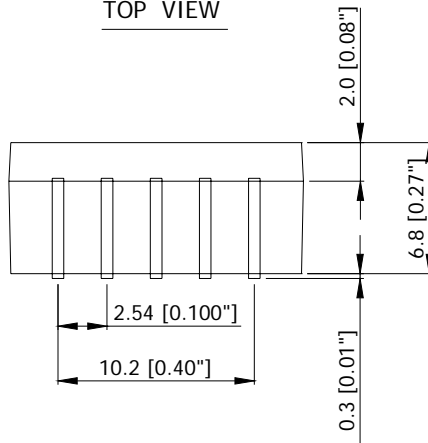

SIDE VIEW

(24V)

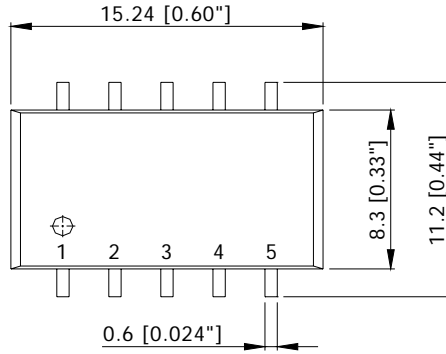

TOP VIEW

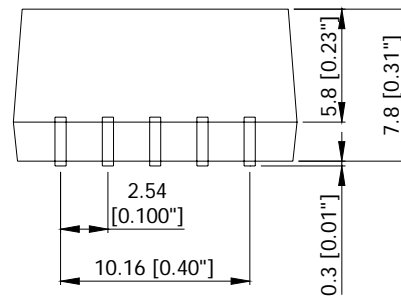

SIDE VIEW

Pin	Dual Output
1	-Vin
2	+Vin
3	NA
4	Common
5	-Vout
6	NA
7	+Vout
8	NA
9	NA
10	NA

Notes:

Dimensions are in millimeters and inches
 Tolerance: X.X ± 0.5mm (X.XX ± 0.02 in)
 X.XX ± 0.25mm (X.XXX ± 0.010 in)

CONTACT: www.delta.com.tw/dcdc

USA:

Telephone:
 East Coast: (888) 335 8201
 West Coast: (888) 335 8208
 Fax: (978) 656 3964
 Email: DCDC@delta-corp.com

Europe:

Phone: +41 31 998 53 11
 Fax: +41 31 998 53 53
 Email: DCDC@delta-es.com

Asia & the rest of world:

Telephone: +886 3 4526107 ext 6220~6224
 Fax: +886 3 4513485
 Email: DCDC@delta.com.tw

WARRANTY

Delta offers a two (2) year limited warranty. Complete warranty information is listed on our web site or is available upon request from Delta. Information furnished by Delta is believed to be accurate and reliable. However, no responsibility is assumed by Delta for its use, nor for any infringements of patents or other rights of third parties, which may result from its use. No license is granted by implication or otherwise under any patent or patent rights of Delta. Delta reserves the right to revise these specifications at any time, without notice.