



Applications

- Cellular Infrastructure
- Wireless communications
- Telecommunications

Description

The HBA48T12280 DC-DC Converter operates over an input voltage range of 36 to 75 VDC and provides a regulated output voltage of 28.0 VDC at up to 12.5 A of output current. The HBA48T12280 provides a regulated 28V bus voltage for today's RF power amplifiers. Its design emphasis is on obtaining the best cost/performance tradeoff. The converter's output is fully isolated from the input, which allows a positive or negative output configuration and the converter to meet Basic Insulation requirements.

The open-frame converter module is constructed with a dual-board approach using discrete magnetics. The standard feature set includes remote on/off (positive or negative logic), output voltage sensing, positive logic output trim, input undervoltage lockout, output voltage shutdown, output overcurrent shutdown, and overtemperature shutdown with hysteresis.

Features

- RoHS compliant for all six substances
- Delivers up to 12.5 A of output current
- Industry-standard half-brick pinout
- On-board input differential LC-filter
- Startup into pre-biased load
- No minimum load required
- Dimensions: 2.40" x 2.28" x 0.50"
(61.0 mm x 57.9 mm x 12.7 mm)
- Meets Basic Insulation requirements of EN60950
- Remote output voltage sense
- Positive or negative logic ON/OFF option
- Output voltage trim range: +18%/-25%
- Protections include: undervoltage lockout, overcurrent, overvoltage, and overtemperature
- Recognized to: UL60950-1/CSA 22.2 No. 60950-1, EN60950-1 and IEC60950-1

Electrical Specifications

Conditions: min. $\leq T_{OPERATING} \leq$ max., min. $\leq V_{IN} \leq$ max, load = resistive, unless otherwise specified.

| Parameter | Notes | Min | Typ | Max | Units |
|--|--|------------|------------|------------|------------|
| Absolute Maximum Ratings | | | | | |
| Input Voltage | Continuous Transient (100 ms) | 0 | | 80 100 | VDC VDC |
| Operating Ambient Temperature | Operation limited by Baseplate temperature | -40 | | 85 | °C |
| Operating Temperature | Component (Tc) Baseplate (Tb) | -40 -40 | | 125 100 | °C °C |
| Storage Temperature | | -55 | | 125 | °C |
| Isolation Characteristics | | | | | |
| Input to Base plate Isolation | | 1500 | | | VDC |
| Input to Output Isolation | | 1500 | | | VDC |
| Output to Base plate Isolation | | 500 | | | VDC |
| Isolation Capacitance | Input to output | | 1.6 | 2.0 | nF |
| Isolation Resistance | | 10 | | | MΩ |
| Feature Characteristics | | | | | |
| Switching Frequency | | | 325 | | kHz |
| Output Voltage Trim Range ¹ | Industry-std. equations ² | -25 | | +18 | % |
| Remote Sense Compensation ¹ | Percent of $V_{OUT(NOM)}$ | 5 | | | % |
| Output Overvoltage Protection | Latching | 120 | | 140 | % |
| Overtemperature Shutdown | Component (Tc) Baseplate (Tb) Hysteresis | 105 10 | 125 110 | | °C °C |
| Turn-On Time from Vin | Time from UVLO to $V_o=90\%V_{o-nom}$ | | | 80 | ms |
| Turn-On Time from enable | Time from Enable to $V_o=90\%V_{o-nom}$ | | | 80 | ms |
| ON/OFF Control (Positive Logic option) | | | | | |
| Converter Off (logic low) | Off threshold level | -0.3 | | 0.8 | VDC |
| | Source Current On/Off to -Vin | | | 1 | mADC |
| Converter On (logic high) | On threshold level | 2.4 | | 35.0 | VDC |

¹ V_{out} can be increased up to 5% via the sense leads or up to 18% via the trim function. However, the total output voltage trim-up should not exceed 18% of $V_{OUT(NOM)}$.

² Trim equations are defined within this document's "Operations" section.

Electrical Specifications (continued)

Conditions: $\min. \leq T_{\text{OPERATING}} \leq \max.$, $\min. \leq V_{\text{IN}} \leq \max.$, load = resistive, $C_{\text{in}}=33 \mu\text{F}$, unless otherwise specified.

| Parameter | Notes | Min | Typ | Max | Units |
|---|---|-----|-----|-------|---------------------|
| Input Characteristics | | | | | |
| Operating Input Voltage Range | | 36 | 48 | 75 | VDC |
| Input Under Voltage Lockout (UVLO) | Non-latching | | | | |
| Turn-on Threshold | | 34 | 35 | 35.99 | VDC |
| Turn-off Threshold | | 32 | 33 | 34.0 | VDC |
| Hysteresis | | 1.5 | 2.0 | | VDC |
| Maximum Input Current | 28 VDC Out @ 12.5 ADC, $V_{\text{in}}=36 \text{ VDC}$ | | | 12 | ADC |
| Input Stand-by Current | $V_{\text{in}} = \text{nom.}$, converter disabled | | | 30 | mADC |
| Input No Load Current (No-load on the output) | $V_{\text{in}} = \text{nom.}$, converter enabled | | | 50 | mADC |
| Input Reflected-Ripple Current, i_c | 25 MHz bandwidth, see Figure T, $V_{\text{in}}=48\text{V}$, $P_o=350\text{W}$ | | | 28 | mA _{PK-PK} |
| | | | | 7 | mA _{RMS} |
| Input-Ripple Current, i_s | | | | 3600 | mA _{PK-PK} |
| | | | | 2600 | mA _{RMS} |
| Input Voltage Ripple Rejection | 120 Hz | | 60 | | dB |

Output Specifications

Conditions: $\min. \leq T_{\text{OPERATING}} \leq \max.$, $\min. \leq V_{\text{IN}} \leq \max.$, load = resistive, $C_{\text{in}}=33 \mu\text{F}$, unless otherwise specified.

| Parameter | Notes | Min | Typ | Max | Units |
|--|---|-------------------------------------|----------|----------|--------------------------|
| Output Characteristics | | | | | |
| Output Voltage Set Point | $T_A \approx \text{room}$, $V_{\text{IN}} = \text{nom.}$, Load = max. | 27.72 | 28.00 | 28.28 | VDC |
| Output Regulation | | | | | |
| Over Line [min. $\leq V_{\text{IN}} \leq \max.$] | $T_A \approx \text{room}$, Load = max. | | ± 24 | ± 56 | mV |
| Over Load [min. $\leq I_o \leq \max.$] | $T_A \approx \text{room}$, $V_{\text{IN}} = \text{nom.}$ | | ± 24 | ± 56 | mV |
| Output Temperature Regulation | | -2.5 | | 2.5 | %/C |
| Output Voltage Range (combined reg.) | Over rated line, load, and temperature | 27.30 | | 28.70 | VDC |
| Output Ripple and Noise – 25 MHz bandwidth | $C_o = 1 \mu\text{F}$ (cer.)+ 220 μF (electrolytic) | | | 280 | mV _{PK-PK} |
| Admissible Ext. Load Capacitance | C_{EXT} : ESR: Load = max. (resistive) | 220 | | 5000 | μF |
| | | 5 | | 180 | m Ω |
| Output Current Range | | 0 | | 12.5 | ADC |
| Current Limit Inception | Non-latching | 104 | | | % |
| | | 13 | | | ADC |
| Short-Circuit Current | P_K : RMS: Non-latching, Short = 10 m Ω | | 65 13 | | Amps A _{RMS} |
| Dynamic Response | | | | | |
| Load Change 50%-75%-50%, $di/dt = 0.1 \text{ A}/\mu\text{s}$ | $C_o = 1 \mu\text{F}$ (cer.)+ 220 μF (AI Electrolytic) | | 500 | | mV |
| | | $di/dt = 1.0 \text{ A}/\mu\text{s}$ | | 500 | mV |
| Settling Time to 10% | | | 600 | | μs |
| Efficiency | | | | | |
| @ 100% Load | (Full parametric curves located within EVT/DVT reports) | | 91 | | % |
| @ 50% Load | | | 90 | | % |



Non-Electrical Specifications

| Parameter | Notes | Min | Typ | Max | Units |
|---|---|---|------|-----|-------|
| Environmental Characteristics | | | | | |
| Operating Humidity | RH (non-condensing) | | | 95 | % |
| Storage Humidity | RH (non-condensing) | | | 95 | % |
| Vibration (Sinusoidal) | GR-63-CORE, Sect. 5.4.2 | 1 | | | g |
| Shock | Half Sinewave, 3-axis | 50 | | | g |
| Physical Characteristics | | | | | |
| Dimensions | Refer to mechanical drawing. | | | | |
| Weight | Refer to mechanical drawing platform notes. | | | | |
| Markings & labeling | Includes: | Part Number, Power-One Logo, Date Code and Country of Manufacture | | | |
| Reliability | | | | | |
| Calculated MTBF | Per Telcordia SR-332, Method 1 Case 1 | | 13.2 | | MHrs |
| EMI & Regulatory Agency Compliance | | | | | |
| Safety | UL/cUL1950, CSA22.2 No.950-95, EN60950 | | | | |
| Insulation | Basic Insulation per Table 2K of UL60950/CSA60950-00, EN60950:2000, and IEC60950:1999 | | | | |
| Flammability | UL94 V-0 | | | | |
| EMC-General Requirements | ETSI EN 300 132-2 V2.1.1 (11/2002) | | | | |
| EMC-Emission and Immunity | ETSI EN 300 386 V1.3.1 (09/2001) | | | | |

Operations

Input and Output Impedance

These power converters have been designed to be stable with a minimum external output capacitor of 220 μ F when used in low inductance input and output circuits. When the ambient temperature is lower than -20 $^{\circ}$ C, use 3 x 220 μ F capacitors rated at 50V to reduce ESR. Use Nichicon UPW1H221MPD or equivalent.

In many applications, the inductance associated with the distribution from the power source to the input of the converter can affect the stability of the converter. It is recommended that a 33 μ F capacitor with a voltage rating of 100 VDC and an ESR <0.1 Ω be used across the input of the HBA48T12280 to ensure stability of the converter. At temperatures < -20 $^{\circ}$ C, use 2 X 33 μ F capacitors to reduce the effective ESR of the input capacitance.

In applications where decoupling capacitance is distributed at the load, the power converter will exhibit stable operation with up to the maximum admissible external load capacitance (C_{EXT}) connected.

(Refer to "Output Specifications" table for value of C_{EXT})

Remote Sense

The remote sense feature of the converter compensates for voltage drops occurring between the output pins of the converter and the load. The SENSE(-) and SENSE(+) pins should be connected at the load or at the point where regulation is required (see Figure A).

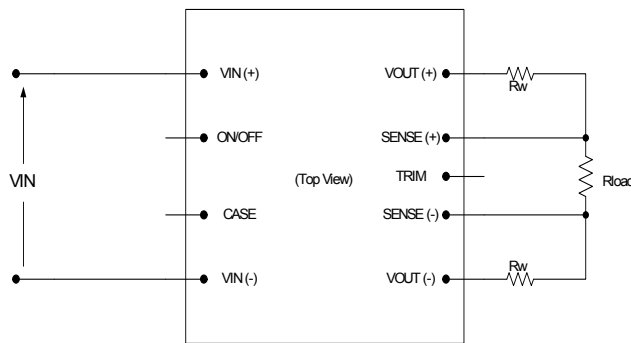

Figure A: Remote sense circuit configuration.

Caution:

If remote sensing is not utilized, the SENSE(-) pin must be connected to the Vout(-) pin, and the SENSE(+) pin must be connected to the Vout(+) pin to ensure the converter will regulate at the specified output voltage. If these connections are not made, the converter will deliver an output voltage that is slightly higher than the specified data sheet value.

Because the sense leads carry minimal current, large traces on the end-user board are not required. However, sense traces should be run side by side and located close to a ground plane to minimize system noise and ensure optimum performance.

The converter's output overvoltage protection (OVP) circuitry senses the voltage across Vout(+) and Vout(-), and not across the +/- sense lines, so the resistance (and resulting voltage drop) between the output pins of the converter and the load should be minimized to prevent unwanted triggering of the OVP.

When utilizing the remote sense feature, care must be taken not to exceed the maximum allowable output power capability of the converter, which is equal to the product of the nominal output voltage and the allowable output current for the given conditions.

When using remote sense, the output voltage at the converter can be increased by as much as 5% above the nominal rating in order to maintain the required voltage across the load. Therefore, the designer must, if necessary, decrease the maximum current (originally obtained from the derating curves) by the same percentage to ensure the converter's actual output power remains at or below the maximum allowable output power.

ON/OFF Control

Models designated Negative Logic Enable turn the converter off during a logic -high or open-circuit and on during a logic-low or a short from the on/off pin to -Vin.

Models designated Positive Logic Enable turn the converter off during a logic-low or a short from on/off pin to -Vin and on during a logic-high or open circuit.

Startup Information (using negative ON/OFF)

Scenario #1: Initial Startup From Bulk Supply

ON/OFF function enabled, converter started via application of V_{IN} .

| Time | Comments |
|-------|---|
| t_0 | ON/OFF pin is ON; system front end power is toggled on, V_{IN} to converter begins to rise. |
| t_1 | V_{IN} crosses undervoltage Lockout protection circuit threshold; converter enabled. |
| t_2 | Converter begins to respond to turn-on command (after 15 ms turn-on delay). |
| t_3 | Converter V_{OUT} reaches 100% of nominal value. |

For this example, the total converter startup time ($t_3 - t_1$) is typically **30 ms**.

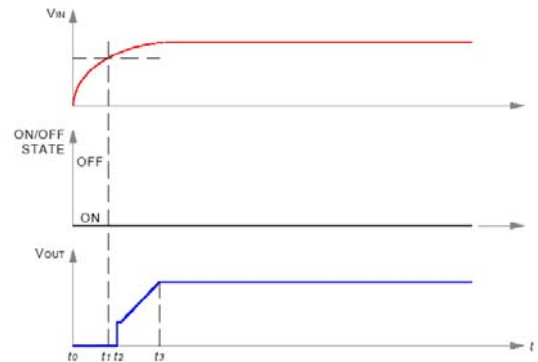

Figure B: Startup scenario #1.

Scenario #2: Initial Startup Using ON/OFF Pin

With V_{IN} previously powered, converter started via ON/OFF pin.

| Time | Comments |
|-------|--|
| t_0 | V_{INPUT} at nominal value. |
| t_1 | Arbitrary time when ON/OFF pin is enabled (converter enabled). |
| t_2 | End of converter turn-on delay. |
| t_3 | Converter V_{OUT} reaches 100% of nominal value. |

For this example, the total converter startup time ($t_3 - t_1$) is typically **15 ms**.

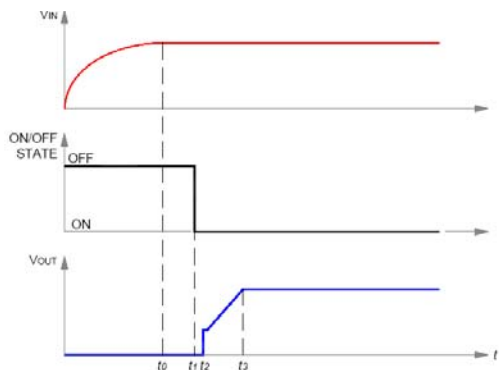

Figure C: Startup scenario #2.

Output Voltage Adjust / TRIM

The output voltage can be adjusted up 18% or down 25% relative to the rated output voltage by the addition of an externally connected resistor. Trim up to 18% at full load is guaranteed at $V_{in} \geq 36V$.

To increase the output voltage, refer to Figure D, a trim resistor, R_{T-INCR} , should be connected between the TRIM and SENSE(+), with a value of:

$$R_{T-INCR} = \frac{V_{O-NOM}(100 + \Delta)}{1.225\Delta} - \frac{(100 + 2\Delta)}{\Delta} \quad [k\Omega]$$

where,

R_{T-INCR} = Required value of trim-up resistor [kΩ]

V_{O-NOM} = Nominal value of output voltage [V]

$$\Delta = \left| \frac{(V_{O-REQ} - V_{O-NOM})}{V_{O-NOM}} \right| \times 100 \quad [\%]$$

V_{O-REQ} = Desired (trimmed) output voltage [V].

When trimming up, care must be taken not to exceed the converter's maximum allowable output power. See the previous section for a complete discussion of this requirement.

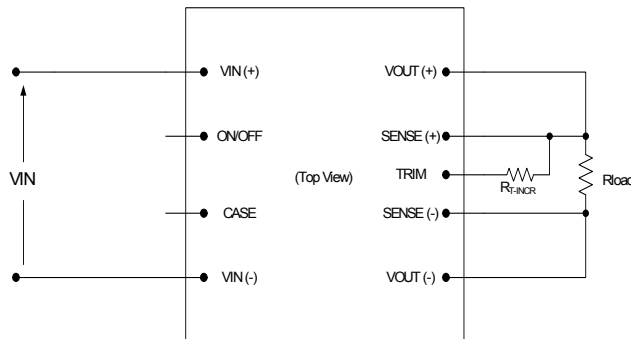

Figure D: Configuration for increasing output voltage.

To decrease the output voltage (Figure E), a trim resistor, R_{T-DECR} , should be connected between the TRIM and SENSE(-), with a value of:

$$R_{T-DECR} = \frac{100}{|\Delta|} - 2 \quad [k\Omega]$$

where,

R_{T-DECR} = Required value of trim-down resistor [kΩ]

and Δ is defined above.

Note:

The above equations for calculation of trim resistor values match those typically used in conventional industry-standard models.

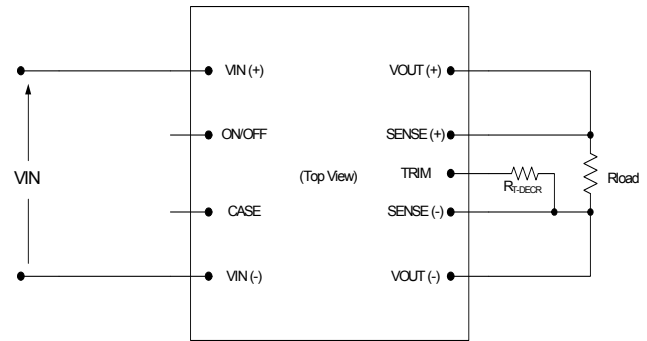

Figure E: Configuration for decreasing output voltage.

Trimming/sensing beyond 118% of the rated output voltage is not an acceptable design practice, as this condition could cause unwanted triggering of the output overvoltage protection (OVP) circuit. The designer should ensure that the difference between the voltages across the converter's output pins and its sense pins does not exceed 105% of $V_{OUT}(nom)$, or:

$$[V_{OUT(+)} - V_{OUT(-)}] - [V_{SENSE(+)} - V_{SENSE(-)}] \leq V_{O-NOM} \times 10\% \quad [V]$$

This equation is applicable for any condition of output sensing and/or output trim.

The output voltage can also be trimmed by applying an external control voltage source, V_{TRIM} , directly to the input of the trim pin using the following equation (refer to Figure F for connections):

$$V_{TRIM} = 1.225 + (0.0088 \cdot \Delta V_O)$$

Where $\Delta V_O = (V_{REQ'D} - V_{NOM})$; if ΔV_O calculates to a negative value, the negative sign should be included in the V_{TRIM} equation. All limitations associated with



limits of trim range previously specified must be observed.

Note: It is important to note that when using this trimming method the control voltage, V_{TRIM} , should be applied to the trim pin only after the converter output has stabilized at its nominal output level. Applying V_{TRIM} to the trim pin prior to enable may result in a discontinuous start-up waveform.

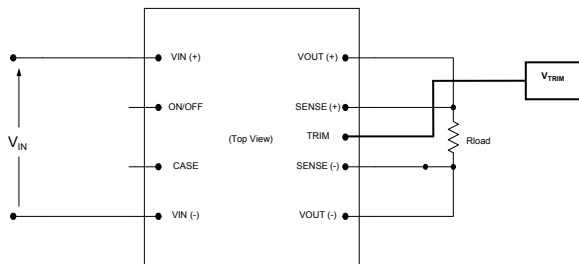

Figure F: Configuration for changing output voltage by using an external control voltage.

If the user application requires the use of both resistive and voltage mode trimming, the above equations would need to be modified; please consult Power-One Technical Support.

Protection Features

Input Undervoltage Lockout (UVLO)

Input undervoltage lockout is standard with this converter. The converter will shut down when the input voltage drops below a pre-determined voltage.

The input voltage must be typically 35 V for the converter to turn on. Once the converter has been turned on, it will shut off when the input voltage drops typically below 33 V. This feature is beneficial in preventing deep discharging of batteries used in telecom applications.

Output Overcurrent Protection (OCP)

The converter is protected against overcurrent or short circuit conditions. Upon sensing an overcurrent condition, the converter will switch to constant current operation and thereby begin to reduce output voltage. When the output voltage drops below 10% of the nominal value of output voltage, the converter will shut down.

Once the converter has shut down, it will attempt to restart nominally every 100 ms with a typical 15% duty cycle. The attempted restart will continue indefinitely until the overload or short circuit condition is removed or the output voltage rises above 10% of its nominal value.

Once the output current is brought back into its specified range, the converter automatically exits the hiccup mode and continues normal operation.

Output Overvoltage Protection (OVP)

The converter will shut down if the output voltage across $V_{out}(+)$ and $V_{out}(-)$ exceeds the threshold of the OVP circuitry. The OVP circuitry contains its own reference voltage, independent of the output voltage regulation loop. Once the converter has shut down it will latch off. The latch can be reset by toggling the enable pin OFF then ON or by recycling the input voltage.

Overtemperature Protection (OTP)

The converter will shut down under an overtemperature condition to protect itself from overheating caused by operation outside the thermal derating curves, or operation in abnormal conditions such as system fan failure. After the converter has cooled to a safe operating temperature, it will automatically restart.

Safety Requirements

The converters meet North American and International safety regulatory requirements per UL60950 and EN60950 Basic Insulation is provided between input and output.

To comply with safety agencies' requirements, an input line fuse must be used external to the converter. A 20-Amp fuse is recommended for use with this product.

The HBA48T12280 converter is UL approved for a maximum fuse rating of 20 Amps. To protect a group of converters with a single fuse, the rating can be increased from the recommended value above.

Characterization

General Information

The converter has been characterized for many operational aspects, to include thermal derating (maximum load current as a function of ambient temperature and airflow) for horizontal mountings, efficiency, startup and shutdown parameters, output ripple and noise, transient response to load step-change, overload, and short circuit.

Test Conditions

All data presented was taken with the converter soldered to a test board, specifically a 0.060" thick printed wiring board (PWB) with four layers. The top and bottom layers were not metalized. The two inner layers, comprised of two-ounce copper, were used to provide traces for connectivity to the converter.

The lack of metallization on the outer layers as well as the limited thermal connection ensured that heat transfer from the converter to the PWB was



minimized. This provides a worst-case but consistent scenario for thermal derating purposes.

All measurements requiring airflow were made in the vertical and horizontal wind tunnel using thermocouples for thermometry.

Ensuring components on the converter do not exceed their ratings is important in order to maintain high reliability. If one anticipates operating the converter at or close to the maximum loads specified in the derating curves, it is prudent to check actual derating temperatures in the application. Thermographic imaging and thermocouples can be used. The use of AWG #40 thermocouples is recommended to ensure measurement accuracy. Careful routing of the thermocouple leads will further minimize measurement error.

Thermal Derating

Figure G shows the Output Current versus Baseplate Temperature. When the user keeps the baseplate at 100°C or, less and a Tamb of 85°C or, less then the full 12.5 Amps of current is available to the user and there still is adequate de-rating of the components on the PCBs. Once the baseplate goes above 100°C, the unit may shut down.

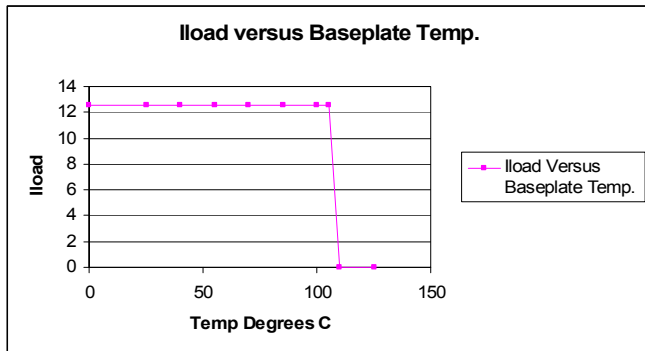

Figure G: Output derating with baseplate temperature vs. load.

Efficiency

Figure H shows the efficiency vs. load current plot for ambient temperature of 25 °C, airflow rate of 300 LFM (1.5 m/s) with horizontal mounting and input voltages of 36 V, 48 V, 60 V and 75 V.

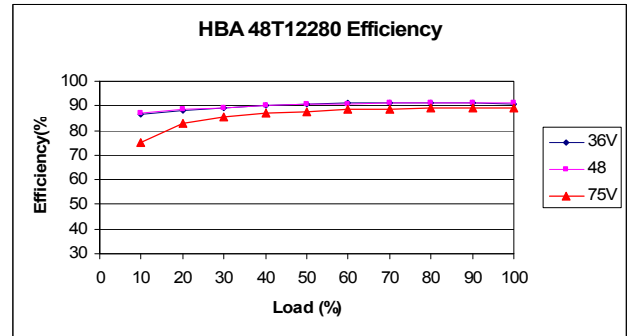

Figure H: Efficiency at 25° Celsius.

Power Dissipation

Figure I shows the power dissipation vs. de-rated load current plot for Ta = 25 °C, 40 °C, 55 °C, 70 °C, and 85 °C. LFM was measured at 400 LFM, 300 LFM, 200 LFM, 100 LFM, and 50 LFM. Unit was equipped with a HSI-502-60H heat sink. The assembly was vertical mounted and the input voltage was set to 48 VDC.

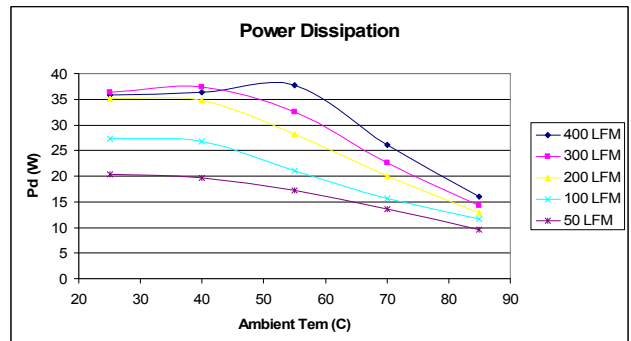

Figure I: Power dissipation at derated current using HSI-502-60H heat sink.

Startup

Output voltage waveforms, during the turn-on transient using the ON/OFF pin and Vcc for full rated load currents (resistive load) with external load capacitance of 220 μF are shown in Figure J and Figure K, respectively.



22-Oct-09
13:06:16

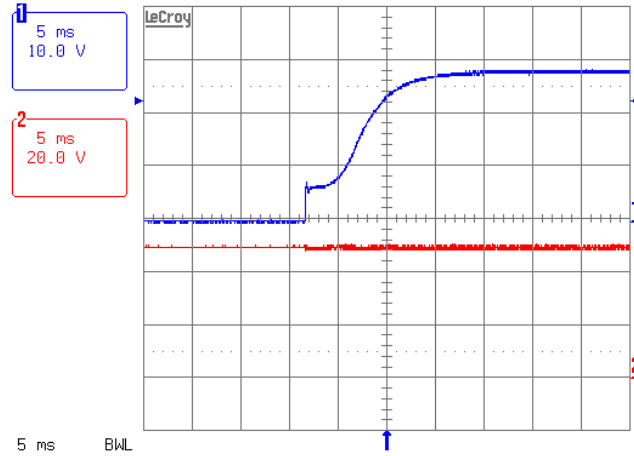

Figure J: Start-up using the on-off enable pin. $I_L=12.5\text{Amps}$, $C_{out}=220\ \mu\text{F}$, $V_{in}=48\ \text{VDC}$.

22-Oct-09
13:10:18

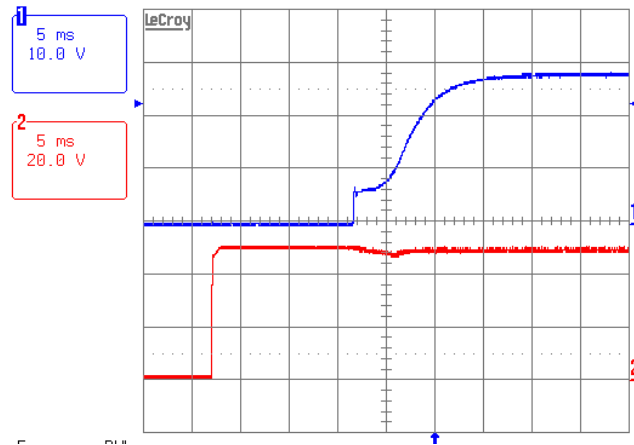

Figure K: Start-up using V_{cc} . $I_L=12.5\ \text{Amps}$, $C_{out}=220\ \mu\text{F}$, $V_{in}=48\ \text{VDC}$.

Dynamic Load Response

Figure L shows the output voltage transient when the output of the HBA has a 7.5 to 10 amp transient with a slew rate of 0.1Amp per microsecond is applied to the output. The output has a $C_{out} = 220\ \mu\text{F}$. Figure M shows the output voltage transient when the output of the HBA has a 7.5 to 10 amp transient with a slew rate of 1.0 Amp per microsecond is applied to the output. The output has a $C_{out} = 4700\ \mu\text{F}$.

20-Oct-09
16:08:23

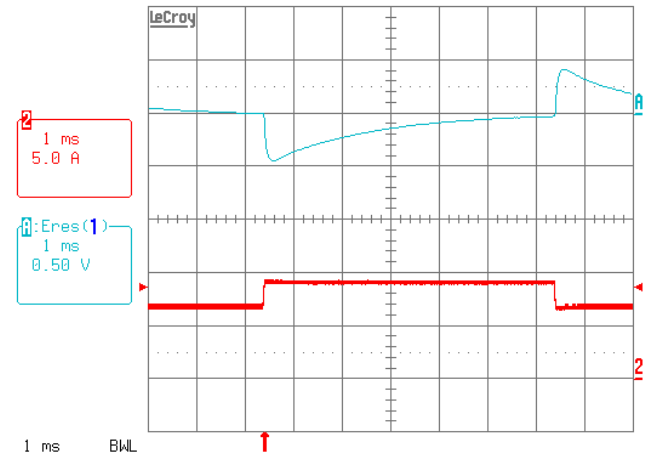

Figure L: Output voltage response to load current step-change (7.5A – 10A – 7.5A) at $V_{in} = 48\ \text{V}$. Current slew rate: 0.1 A/ μs . $C_o = 220\ \mu\text{F}$ aluminum electrolytic.

20-Oct-09
18:37:27

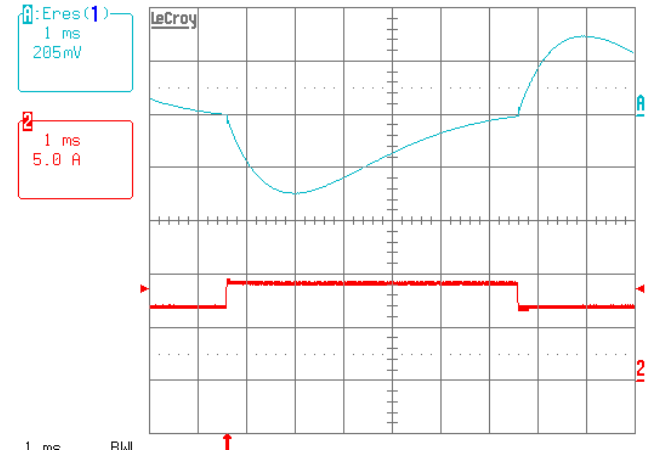

Figure M: Output voltage response to load current step-change (7.5A – 10A – 7.5A) at $V_{in} = 48\ \text{V}$. Current slew rate: 1.0 A/ μs . $C_o = 4700\ \mu\text{F}$ aluminum electrolytic.

Ripple and Noise

Figure N shows the output voltage ripple waveform, measured at full rated load current with a 10 μF tantalum and 1 μF ceramic capacitor across the output. Note that all output voltage waveforms are measured across a 1 μF ceramic capacitor. The input reflected-ripple current waveforms are obtained using the test setup shown in Figure O.

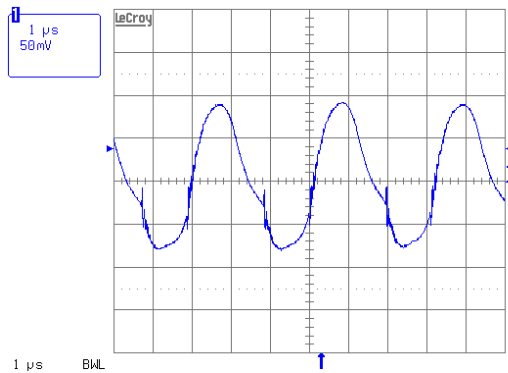

Figure N: Output Ripple Voltage, $I_L=12.5$ Amps, $C_{out}=220 \mu F$, $V_{in}=48$ VDC.

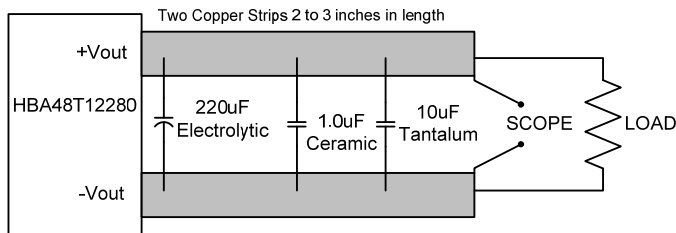

Figure O: Output ripple measurement test setup

Note: Use a 0.1 μF ceramic with a 10 μF tantalum capacitor. Scope measurement should be made using a BNC socket. Position loads between 51 mm and 76 mm (2 in. and 3 in.) from the module. The minimum output capacitance as specified for proper operation must be present during this measurement.

Output Current Limiting

Figure P shows the output voltage when the unit goes into current limit. $V_{in}=48$ VDC and $C_{out}=220 \mu F$.

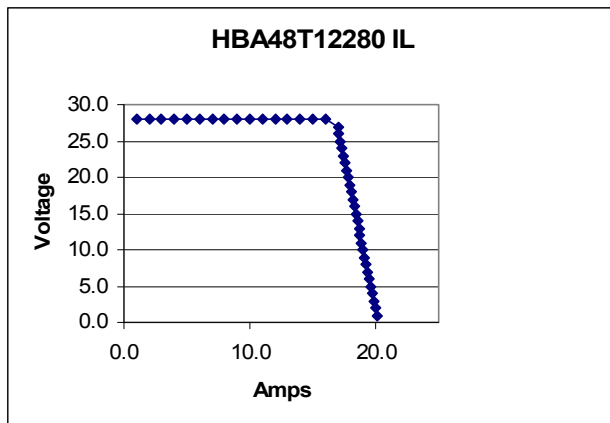

Figure P: Current limit of the HBA with $V_{in} = 48$ VDC.

Electromagnetic Compatibility (EMC)

EMC requirements must be met at the end-product system level, as no specific standards dedicated to EMC characteristics of board mounted component

DC-DC converters exist. However, Power-One tests its converters to several system level standards, the primary of which is the more stringent EN55022, Information technology equipment - Radio disturbance characteristics-limits and methods of measurement.

With the addition of a simple external filter, the HBA48T12280 converter will pass the requirements of Class A conducted emissions per EN55022 and FCC requirements. The recommended EMI filter is shown in Figure Q. Please contact Power-One Applications Engineering for details of this testing.

The results of EMI testing are shown in Figure R and Figure S.

Recommended EMI filter for Class A

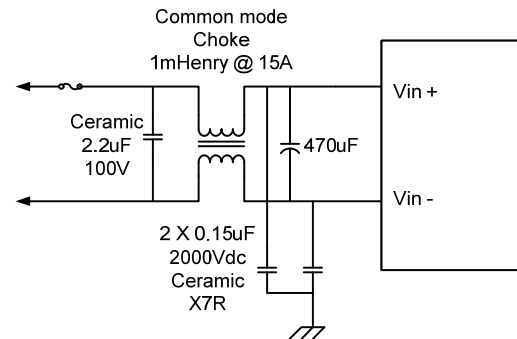

Figure Q: Input filter configuration required to meet CISPR 22 Class A for conducted emissions.

Part List for Input Filter

| <u>Ref. Des</u> | <u>Description</u> | <u>Manufacture</u> |
|-----------------|---|----------------------------|
| C1 | 2.2 μF @100V MLC Capacitor (1812) | AVX or Equivalent (Equiv.) |
| C3 | 470 μF @ 100V Alum. Electrolytic Capacitor | |
| C5, 6 | 0.15 μF , 2000Vdc MLC Capacitor | AVX or Equiv. |
| L1 | 1.0 mH Common mode choke (15 Amp) | |

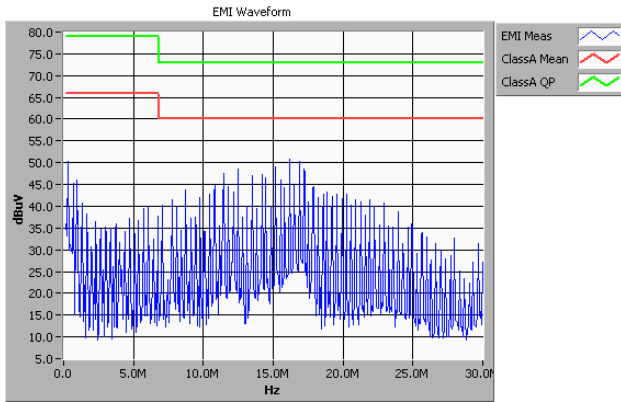

Figure R: Measurement of EMI current on Vin+.

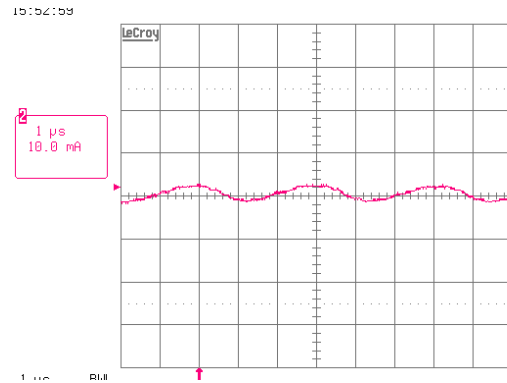

Figure U: Measurement of Ic with Vcc. II = 12.5Amps, Cout = 220 µF, Vin = 48 VDC.

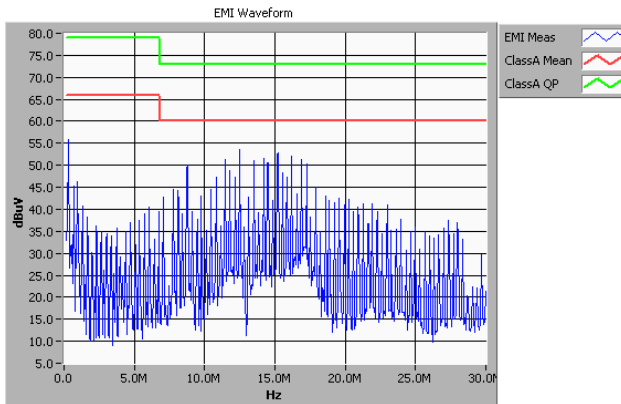

Figure S: Measurement of EMI current on Vin-.

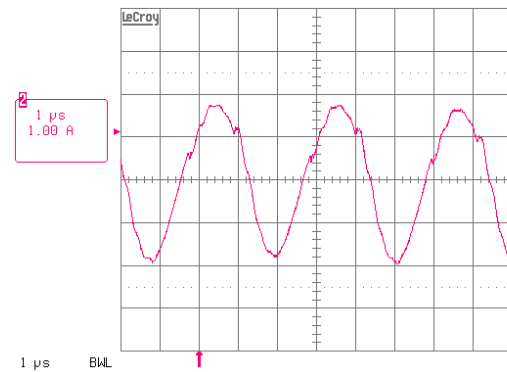

Figure V: Measurement of Is with Vcc II = 12.5 Amps, Cout=220 µF, Vin=48 VDC.

Input Reflected Ripple

The input reflected ripple is measured as shown in Figure T. Ic is shown in Figure U AND Is is shown in Figure V.

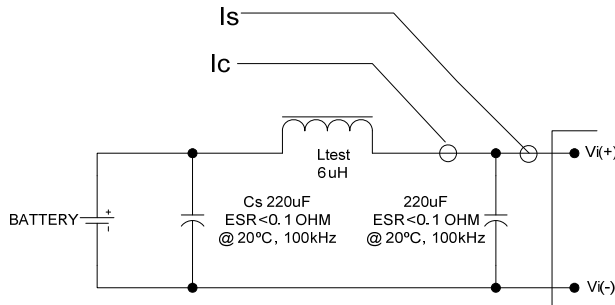

Figure T: Test setup for measuring input reflected ripple currents, Ic and Is.

Back-Feed Capability

The HBA is not a synchronous rectifier power converter. It uses traditional diode rectifiers and does not have the capability to sink current into the output pins. Therefore, back feed capability is not a concern.

Physical Information

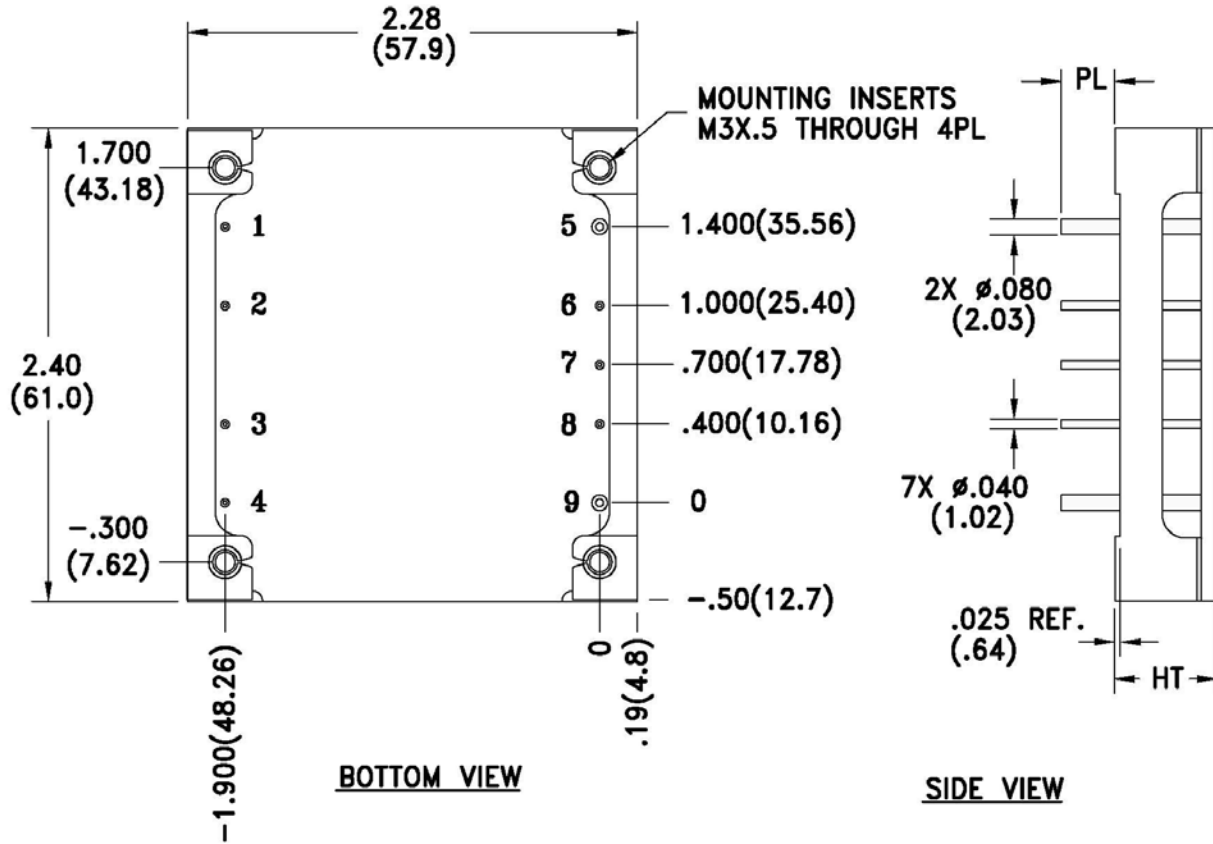

Figure W: HBA48T12280 Mechanical Outline

| Pin Assignments: | Function |
|------------------|----------|
| 1 | Vin + |
| 2 | ON/OFF |
| 3 | Case |
| 4 | Vin - |
| 5 | Vout - |
| 6 | SENSE- |
| 7 | TRIM |
| 8 | SENSE+ |
| 9 | Vout + |

| Pin Option | PL Pin Length |
|------------|------------------|
| | ±0.005 [±0.13] |
| A | 0.188 [4.78] |
| B | 0.145 [3.68] |

| Mechanical Tolerances | |
|-----------------------|---------------|
| Inches | Millimeters |
| X.XX = ± 0.020 | X.X = ± 0.5 |
| X.XXX = ± 0.010 | X.XX = ± 0.25 |

| HT (Max. Height) | CL (Min. Clearance) |
|----------------------|------------------------|
| Ht Tol ±0.020 [+0.5] | +0.022 [+0.55] |
| | -0.000 [-0.00] |
| 0.50 [12.7] | 0.003 [0.075] |

Notes:

- Weight is 77.8 grams.

Converter Part Number Ordering Information

| Product Series | Input Voltage | Mounting Scheme | Rated Load Current | Output Voltage | | ON/OFF Logic | Maximum Height [HT] | Pin Length [PL] | Special Features | Environmental |
|-------------------|---------------|------------------|--------------------|----------------|----------|----------------------------------|--------------------------------------|---|--|--|
| HBA | 48 | T | 12 | 280 | - | P | C | B | P | G |
| Half-Brick Format | 36-75 V | T ⇒ Through-hole | 12.5 A | 280 ⇒ 28 V | | N ⇒ Negative P ⇒ Positive | <u>Through-hole</u> C ⇒ 0.50" | <u>Through-hole</u> A ⇒ 0.188" B ⇒ 0.145" | P ⇒ non-Threaded Standoff Q ⇒ Threaded Standoff | G ⇒ RoHS compliant for all 6 substances No Suffix ⇒ Lead solder exemption compliant |

The example above describes P/N: HBA48T12280-PCBPG as follows:

36-75 V input, through-hole mounting, 12.5 A @ 28 V output, positive ON/OFF logic, a maximum height of 0.50", an I/O pin length of 0.188", a single board platform (no baseplate), and fully RoHS compliant (PB-free solder)

Please consult factory for the complete list of available options.

NUCLEAR AND MEDICAL APPLICATIONS - Power-One products are not designed, intended for use in, or authorized for use as critical components in life support systems, equipment used in hazardous environments, or nuclear control systems without the express written consent of the respective divisional president of Power-One, Inc.

TECHNICAL REVISIONS - The appearance of products, including safety agency certifications pictured on labels, may change depending on the date manufactured. Specifications are subject to change without notice.