

# For VCXO Monolithic IC MM3168 Series

## Outline

This IC is an IC for VCXO and supports a 27 MHz crystal for MPEG2 demodulation for digital ground waves. The frequency variation range is 200 ppm, and the power consumption is 7 mA typ.

## Features

1. Operation voltage	3.15~3.45V
2. Frequency variable range	200ppm
3. Variable voltage	0~3.3V
4. Output current	12mA typ.
5. Operation frequency	27MHz
6. Shunt capacitance	C0 : 3pF typ.
7. Linear equivalent resistance	35Ω max.
8. Load capacity	13pF

## Package

SOP-8D  
SOT-26A

## Applications

1. Ground wave digital tuner
2. DVD recorder
3. Other

Equivalent Circuit

■ MM3168AFBE

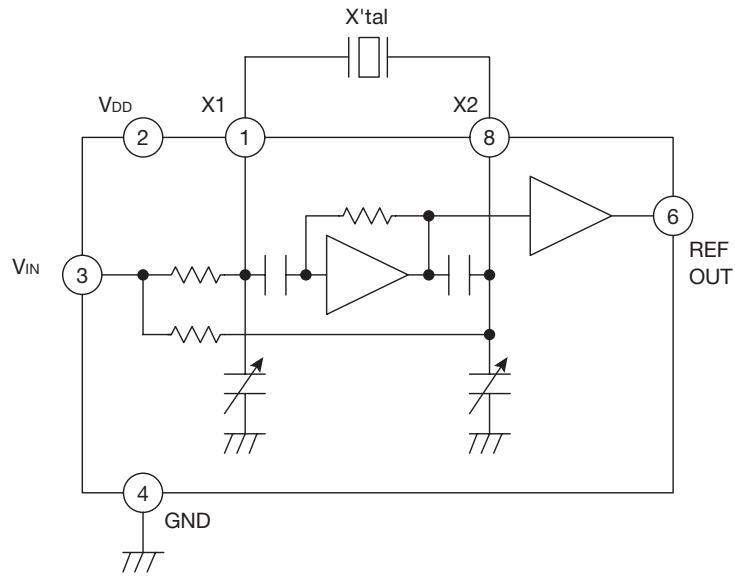

■ MM3168ANLE

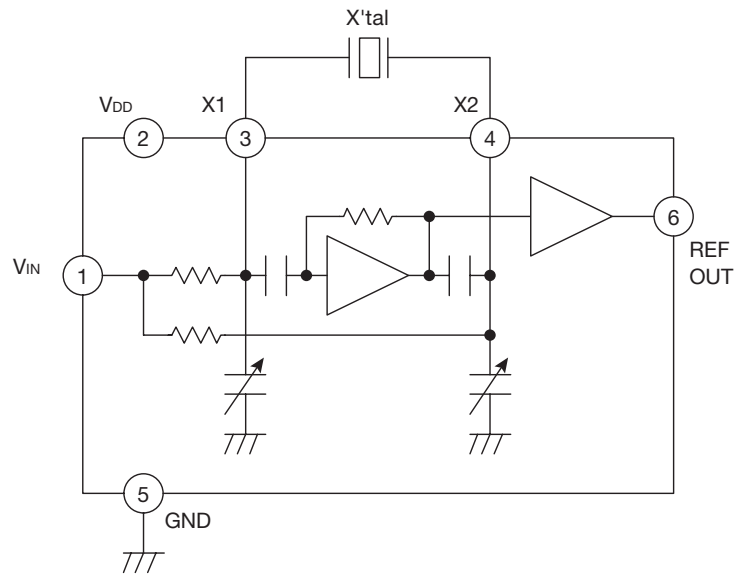

## Pin Assignment

### MM3168AFBE

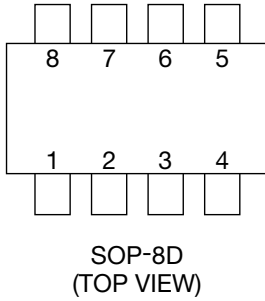

1	X1
2	V <sub>DD</sub>
3	V <sub>IN</sub>
4	GND
5	N.C.
6	REFOUT
7	N.C.
8	X2

### MM3168ANLE

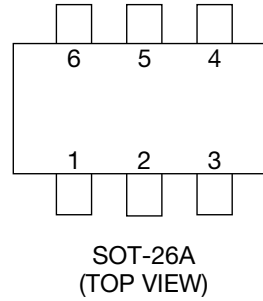

1	V <sub>IN</sub>
2	V <sub>DD</sub>
3	X1
4	X2
5	GND
6	REFOUT

## Pin Description

### MM3168AFBE

Pin No.	Pin Name	Pin type	Function
1	X1	Input	Crystal connection 1
2	V <sub>DD</sub>	Power	Connect to +3.3V (0.01μF decoupling capacitor recommended)
3	V <sub>IN</sub>	Input	Voltage input to VCXO 0 to 3.3V analog input which controls the oscillation frequency of the VCXO. (0.01μF decoupling capacitor recommended)
4	GND	Power	GND
5	N.C.		Don't Connect
6	REFOUT	Output	Clock output
7	N.C.		Don't Connect
8	X2	Input	Crystal connection 2

### MM3168ANLE

Pin No.	Pin Name	Pin type	Function
1	V <sub>IN</sub>	Input	Voltage input to VCXO 0 to 3.3V analog input which controls the oscillation frequency of the VCXO. (0.01μF decoupling capacitor recommended)
2	V <sub>DD</sub>	Power	Connect to +3.3V (0.01μF decoupling capacitor recommended)
3	X1	Input	Crystal connection 1
4	X2	Input	Crystal connection 2
5	GND	Power	GND
6	REFOUT	Output	Clock output

**Absolute Maximum Ratings** (Ta=25°C)

Item	Symbol	Ratings	Units
Storage temperature	T <sub>STG</sub>	-40~+125	°C
Operating temperature	T <sub>OPR</sub>	0~+70	°C
Supply voltage	V <sub>DDmax.</sub>	7	V
All Inputs & outputs	V <sub>INmax.</sub>	-0.3 ≤ V <sub>IN</sub> ≤ V <sub>DD</sub>	V
Allowable loss	Pd	340	mW

**Recommended Operating Conditions**

Item	Symbol	Ratings	Units
Operating temperature	T <sub>OPR</sub>	0~+70	°C
Supply voltage	V <sub>OPR</sub>	3.15~3.45	V
Input Voltage	V <sub>IN</sub>	0.0~3.3	V
Crystal parameters	C0	3.0	pF
	C1	11.4	fF
	CI	17	Ω
	L1	3	mH

**Electrical Characteristics** (Except where noted otherwise, Ta=25°C, V<sub>DD</sub>=3.3V±5%)

Item	Symbol	Measurement conditions	Min.	Typ.	Max.	Units
<b>DC Electrical Characteristics</b>						
Operating supply current	I <sub>DD</sub>	No load		3.5	7	mA
Output voltage H	V <sub>OH</sub>	I <sub>o</sub> =5mA	2.4			V
Output voltage L	V <sub>OL</sub>	I <sub>o</sub> =5mA			0.4	V
Short circuit current	I <sub>os</sub>			±50		mA
<b>AC Electrical Characteristics</b>						
V <sub>IN</sub> control voltage	V <sub>IA</sub>		0		V <sub>DD</sub>	V
Output frequency	f	V <sub>IN</sub> =1.2V	26.9992	27	27.0008	MHz
Crystal pullability	f <sub>p</sub>	0V<V <sub>IN</sub> <3.3V *Note 1	±100			ppm
VCXO gain	f <sub>g</sub>	V <sub>IN</sub> =1.2V±1.0V *Note 1	90	110	130	ppm/V
Output rise time	t <sub>r</sub>	0.8V to 2.0V, CL=15pF		2		ns
Output fall time	t <sub>f</sub>	2.0V to 0.8V, CL=15pF		2		ns
Output clock duty cycle	t <sub>Duty</sub>	CL=15pF	40	50	60	%
Maximum output jitter, short term	T <sub>j</sub>	CL=15pF		±150		ps

\*Note 1 : External crystal device must conform with Pullabel Crystal Specifications listed on this page.

\*Note 2 : The crystal must be mounted as close to the device as possible and should be on the same side of the PCB as the MM3168.

Any external parasitic capacitance will reduce the pull range of the VCXO. In order to maximize the range, it is important to minimize parasitic capacitance related to X1 and X2 on the PCB.

The ground and power planes should be cut out under the X1 and X2 pins and the Crystal.

There should be no vias between the crystal pins and X1 and X2 device pins.

There should be no signal traces underneath or close to the crystal.

## Measuring Circuit

### MM3168AFBE

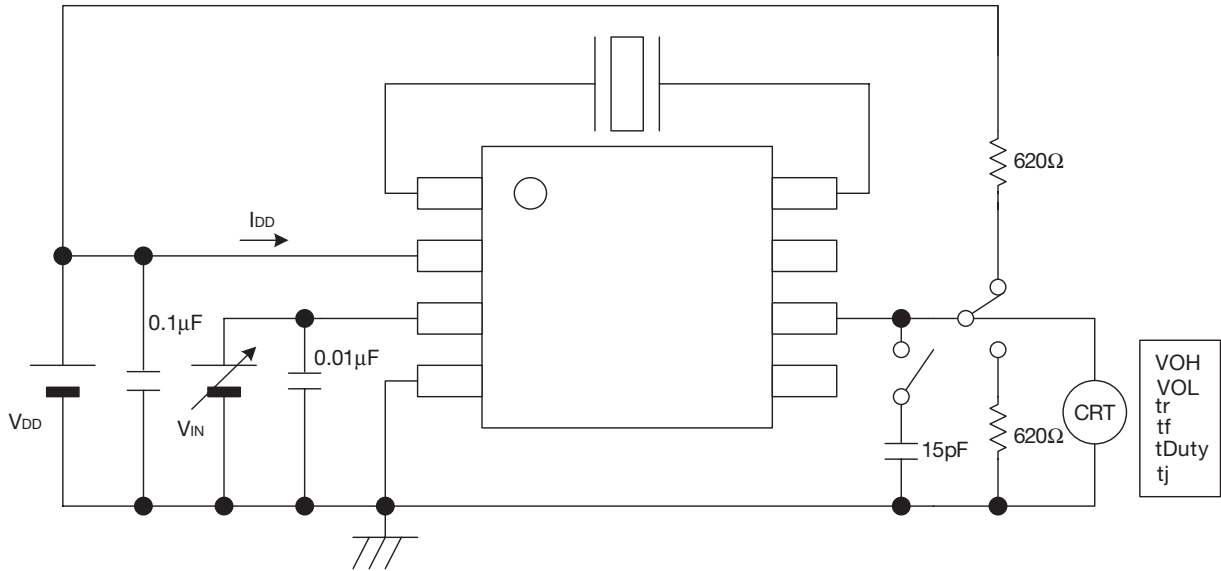

## Characteristics

### MM3168AFBE

