

High-Accuracy Temperature Sensor Monolithic IC MM3154 Series

Outline

This IC is a high-accuracy temperature sensor IC that can linearly output the voltage in response to changes in temperature. The operating temperature range is -40 to 100°C , and the operating supply voltage range is $+2.4$ to $+6.5\text{V}$.

Compared to conventional thermistors and similar devices, it has superior linearity and a maximum temperature accuracy error of $\pm 2.5^{\circ}\text{C}$. It is suitable for use in portable devices as the current consumption is as low as $4.5\mu\text{A}$ typ. ($T_a = 25^{\circ}\text{C}$).

Features

1. High temperature accuracy
2. Low current consumption
3. Temperature - output voltage high linearity
4. Wide operating supply voltage
5. High input stability
6. High load stability

Packages

SC-82ABA
SSON-4A

Applications

1. Cellular phones/PHS
2. Crystal oscillator modules
3. Computers
4. Power modules
5. Battery packs and chargers

Block Diagram

SSON-4A

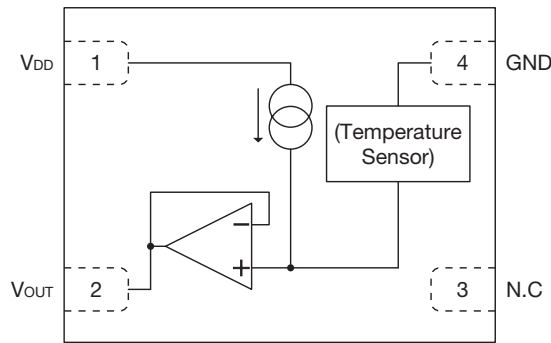

SC-82ABA

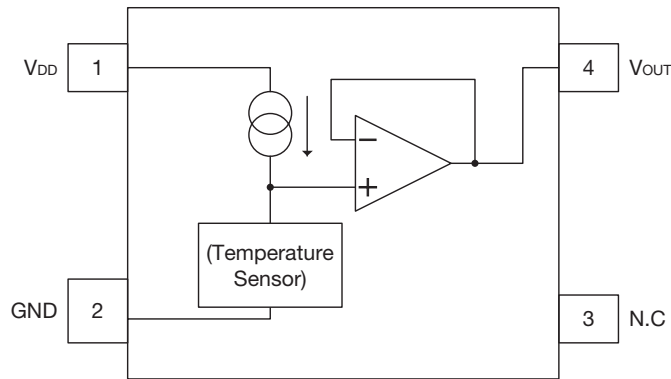

Pin Assignment

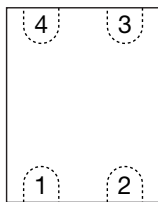

SSON-4A (TOP VIEW)

1	V _{DD}
2	V _{OUT}
3	N.C
4	GND

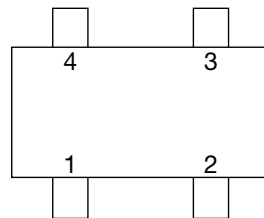

SC-82ABA (TOP VIEW)

1	V _{DD}
2	GND
3	N.C
4	V _{OUT}

Pin Description

SSON-4A

Pin No.	Pin name	Function
1	V _{DD}	Power supply pin
2	V _{OUT}	Output pin
3	N.C	No connect
4	GND	Ground pin

SC-82ABA

Pin No.	Pin name	Function
1	V _{DD}	Power supply pin
2	GND	Ground pin
3	N.C	No connect
4	V _{OUT}	Output pin

Absolute Maximum Ratings (Ta=25°C)

Item	Symbol	Ratings	Units
Maximum supply voltage	V _{DD max.}	-0.3~+7.0	V
Maximum output voltage	V _{OUT}	-0.3~V _{DD} +0.3	V
Allowable loss	P _d	150	mW
Storage temperature	T _{STG}	-55~+150	°C

Recommended Operating Conditions

Item	Symbol	Ratings	Units
Operating supply voltage	V _{DDOPR}	+2.4~+6.5	V
Operating temperature	T _{OPR}	-40~+100	°C

Electrical Characteristics (Except where noted otherwise, Ta=25°C, V_{DD}=5V, I_{OUT}=0A)

Item	Symbol	Measurement conditions	Min.	Typ.	Max.	Units
Accuracy	A _c	-30°C ≤ Ta ≤ 100°C			±2.5	°C
Current consumption	I _{DD}			4.5	8.0	μA
Output voltage (note 1)	V _{OUT}	Ta = -30°C	1.931	1.951	1.971	V
		Ta = 30°C	1.454	1.474	1.494	V
		Ta = 100°C	0.862	0.882	0.902	V
Temperature sensitivity (note 2)	V _{SE}	-30°C ≤ Ta ≤ 100°C	-8.40	-8.20	-8.00	mV/°C
Nonlinearity (note 3)	ΔNL	-20°C ≤ Ta ≤ 80°C		±0.5		%
Line regulation	ΔV _{OUT} / ΔV _{DD}	V _{DD} = +2.4~+6.5V			0.03	%/V
Load regulation *	ΔV _{OUT} / ΔI _{OUT}	I _{OUT} = 0~200μA			1.0	mV

* : Don't flow sink current into output pin (V_{OUT}).

note 1 : Output voltage : V_{OUT}

Terminal voltage at the time of Ta = -30°C, 30°C, and 100°C.

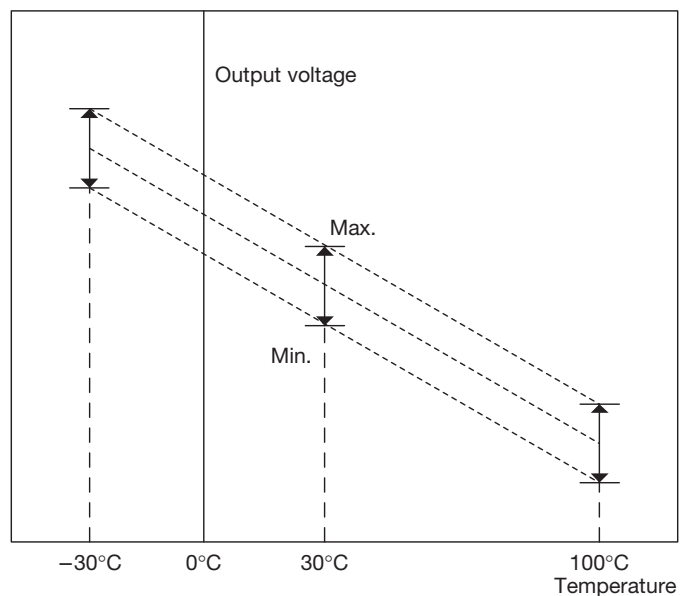

note 2 : Temperature sensitivity : V_{SE}

Temperature coefficient of output voltage calculated from output voltage at the time of $T_a = -30^\circ\text{C}$ and $+100^\circ\text{C}$.

$$V_{SE} = (V_{OUT}(100^\circ\text{C}) - V_{OUT}(-30^\circ\text{C})) / 130$$

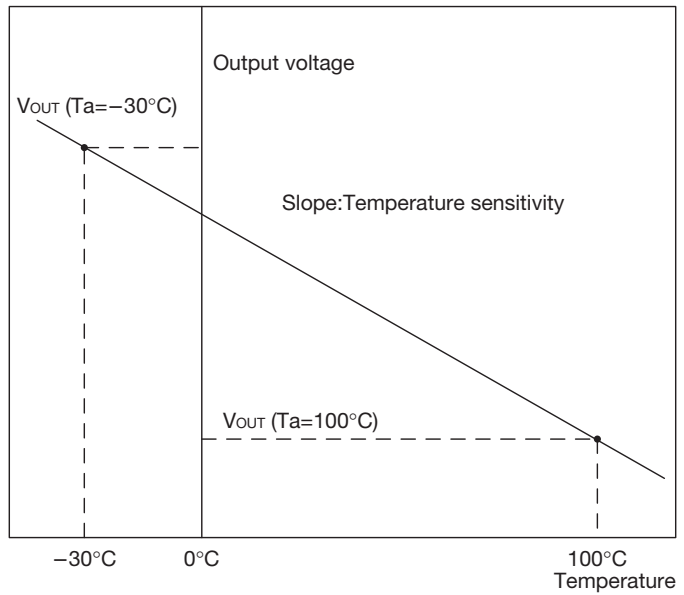

note 3 : Nonlinearity : ΔNL

Characteristic curve of output voltage and deflection with the approximation straight line.

In temperature range from -20 to $+80^\circ\text{C}$, the approximation straight line and the maximum deflection of the measurement value among output voltages obtained from the approximation straight line.

It assumes the approximation straight line to be a straight line to which a is minimized.

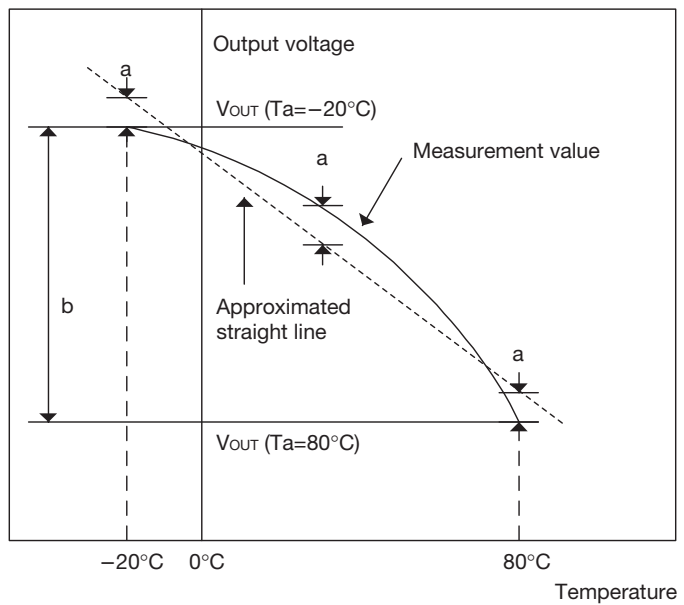

$$\Delta NL = a/b * 100$$

Measuring Circuit

SSON-4A

1

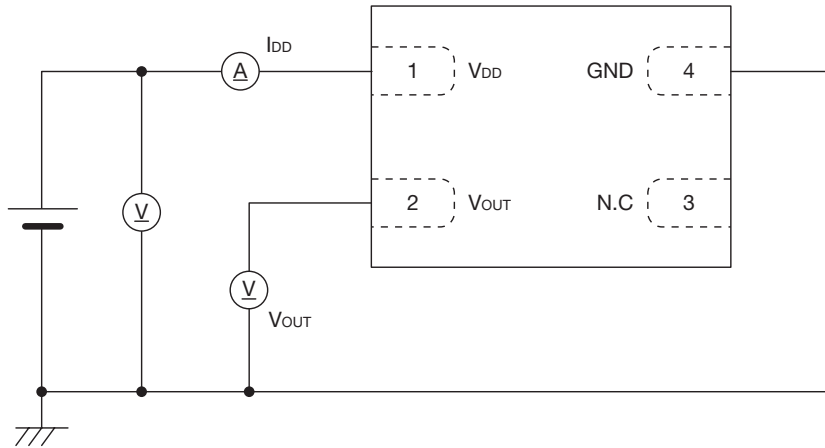

2

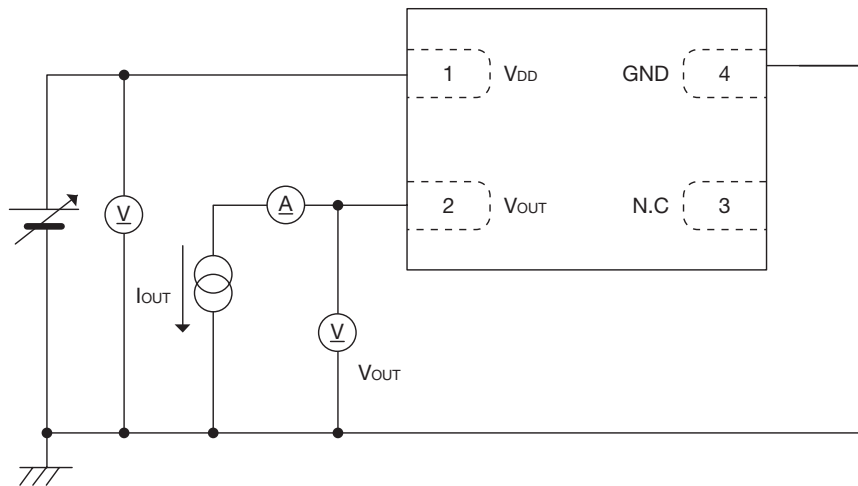

■ SC-82ABA

1

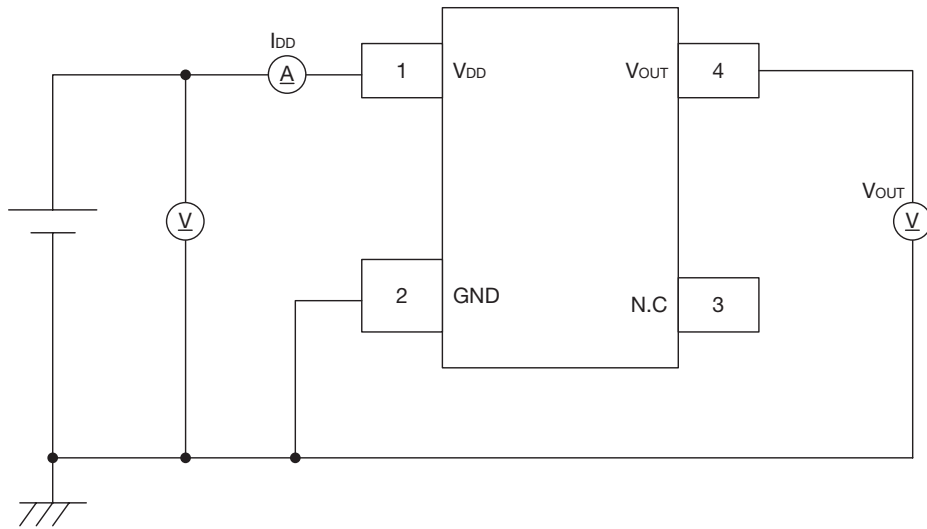

2

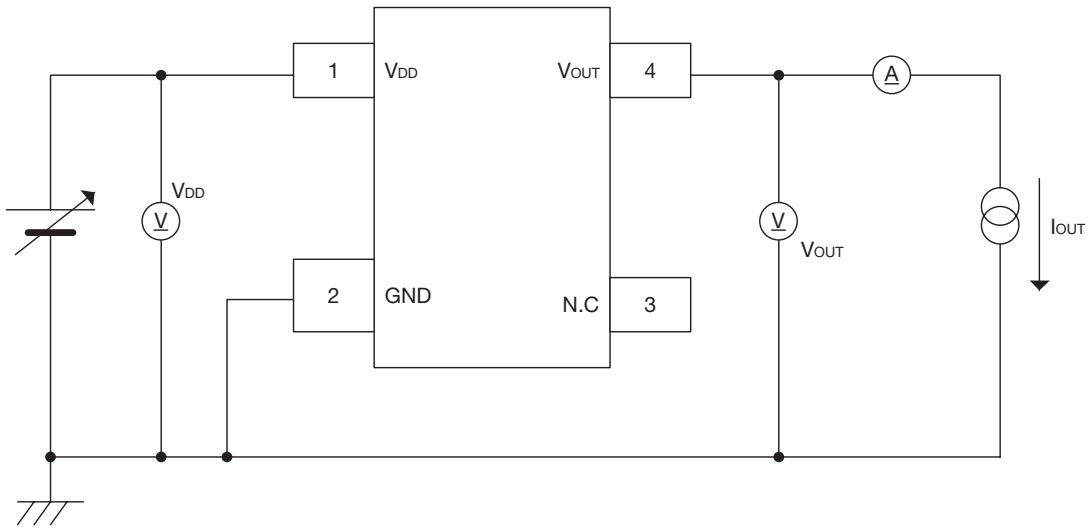

Application Circuit

■ SSON-4A

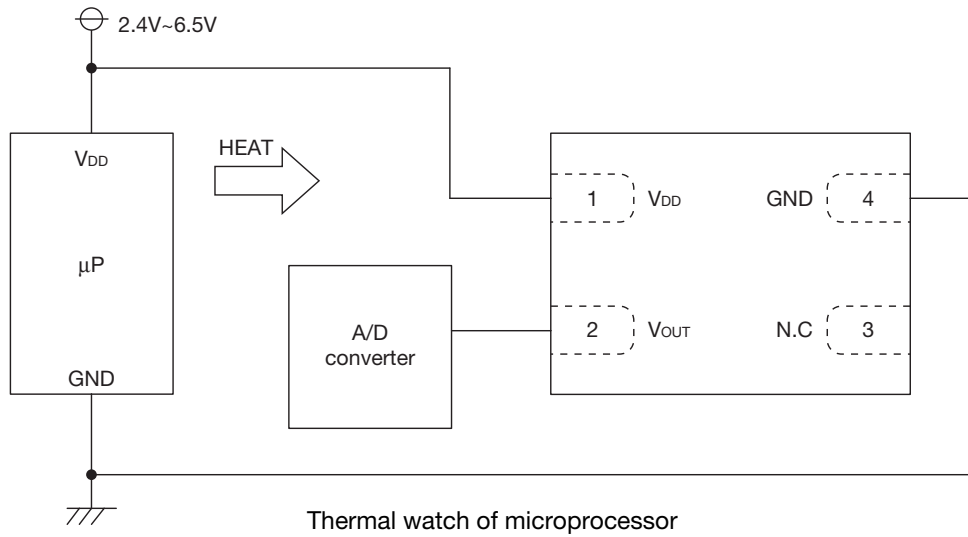

■ SC-82ABA

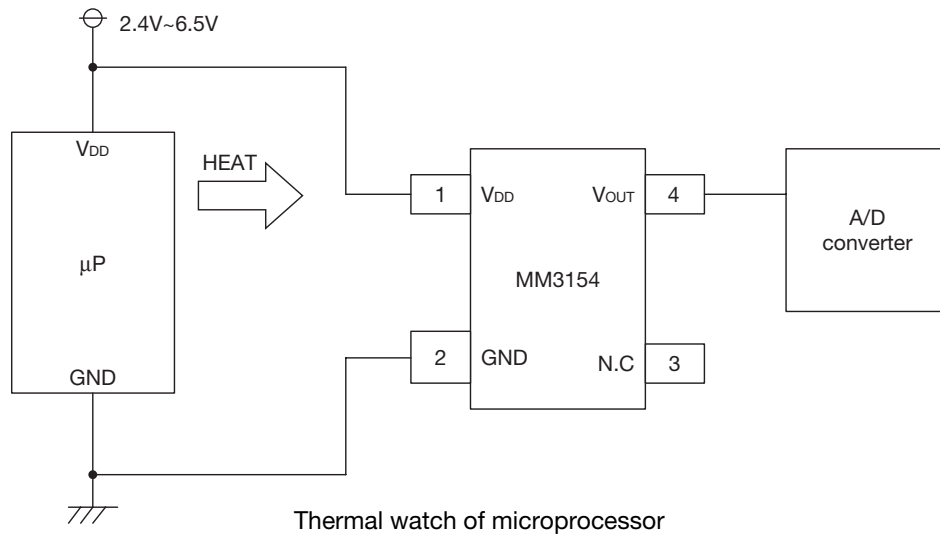

We shall not be liable for any trouble or damage caused by using this circuit.

In the event a problem which may affect industrial property or any other rights of us or a third party is encountered during the use of information described in these circuit, Mitsumi Electric Co., Ltd. shall not be liable for any such problem, nor grant a license therefore.

Characteristics

Output voltage vs Temperature

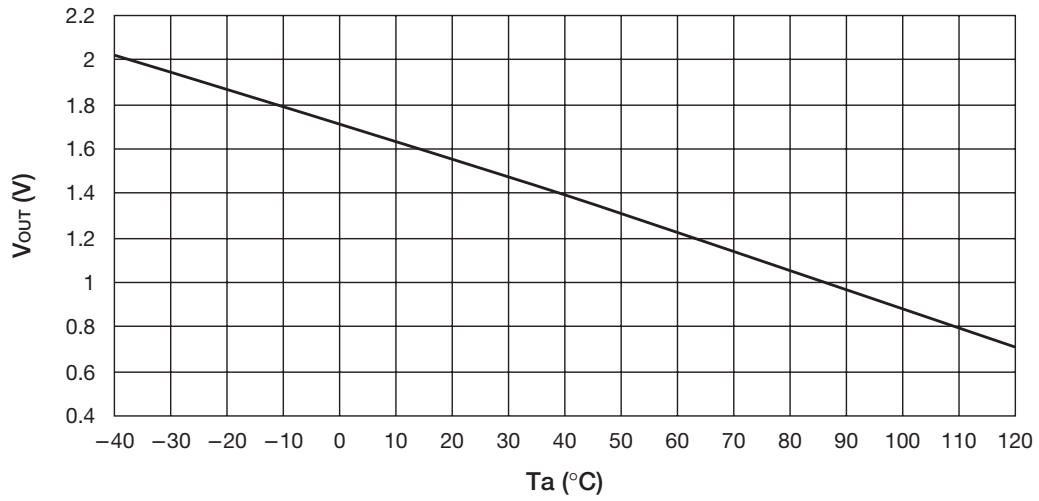

Current consumption vs Temperature

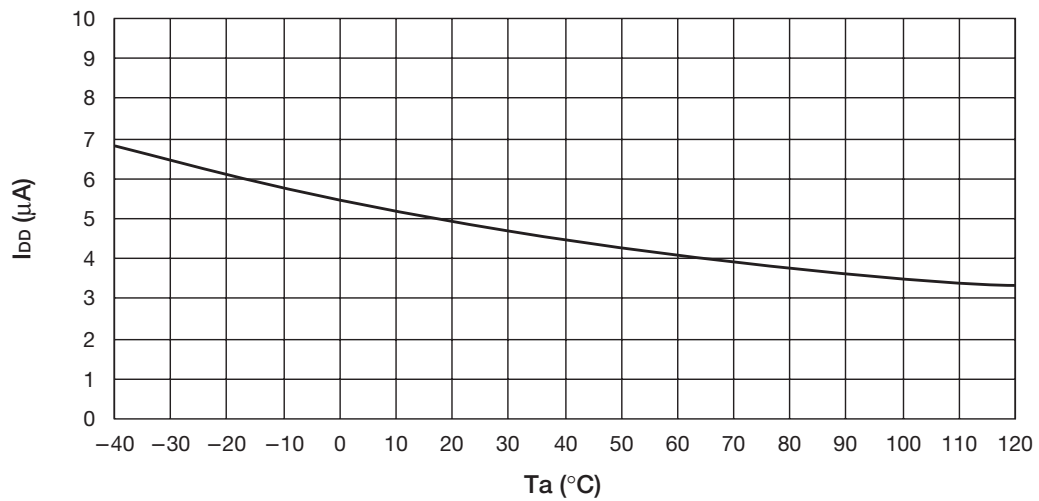

Current consumption vs Supply voltage

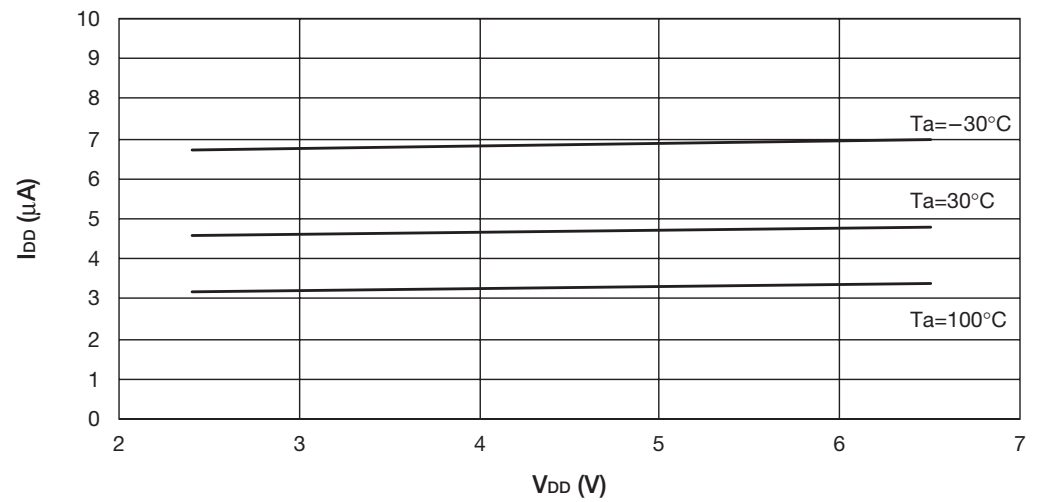

■ Output voltage vs Supply voltage $T_a = -30^\circ\text{C}$

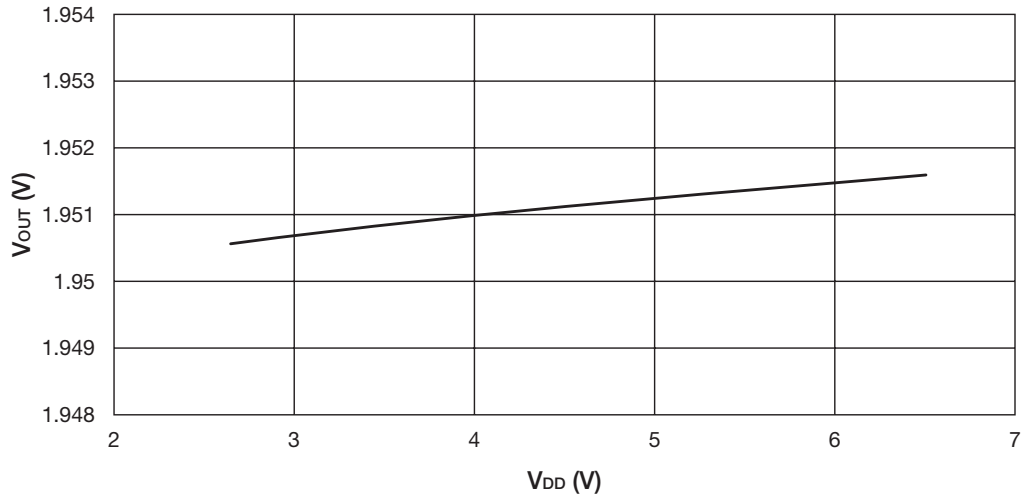

■ Output voltage vs Supply voltage $T_a = 30^\circ\text{C}$

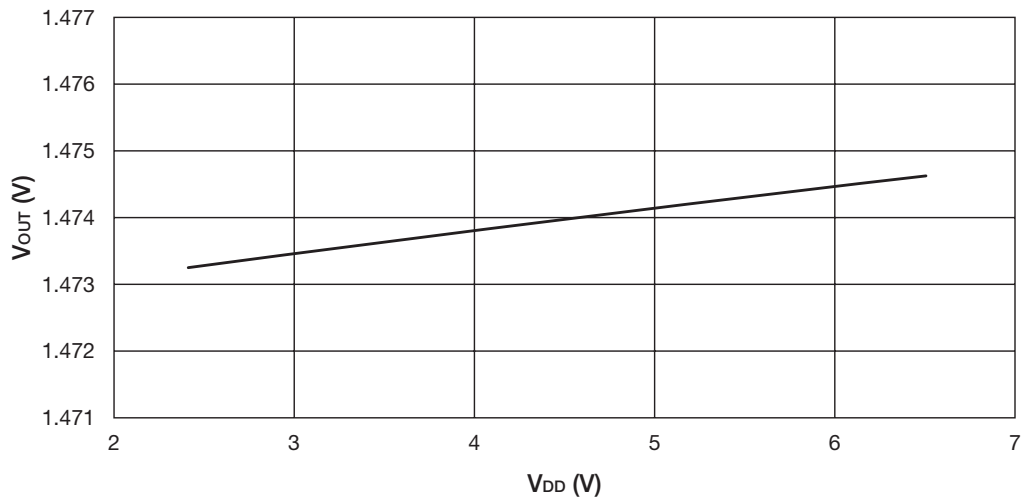

■ Output voltage vs Supply voltage $T_a = 100^\circ\text{C}$

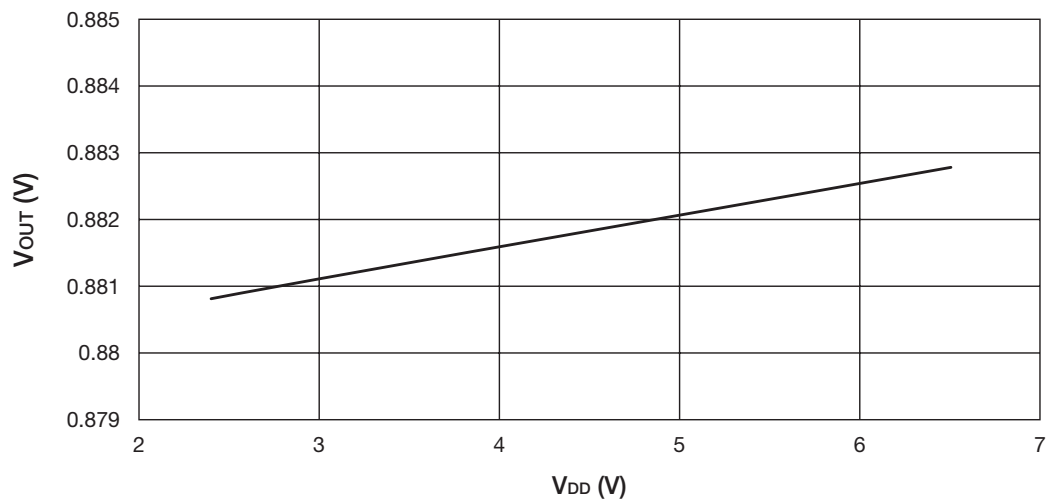

■ Accuracy vs Temperature

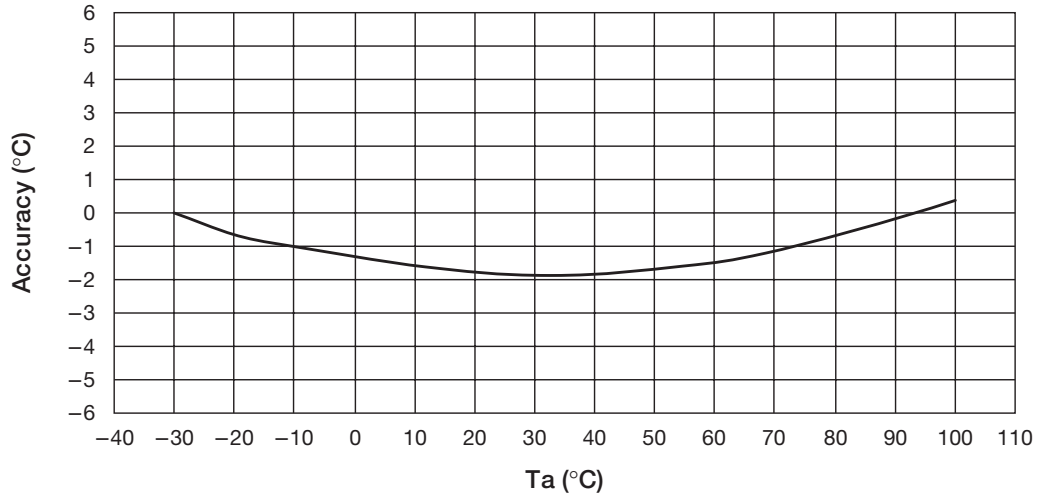

■ Start-up response

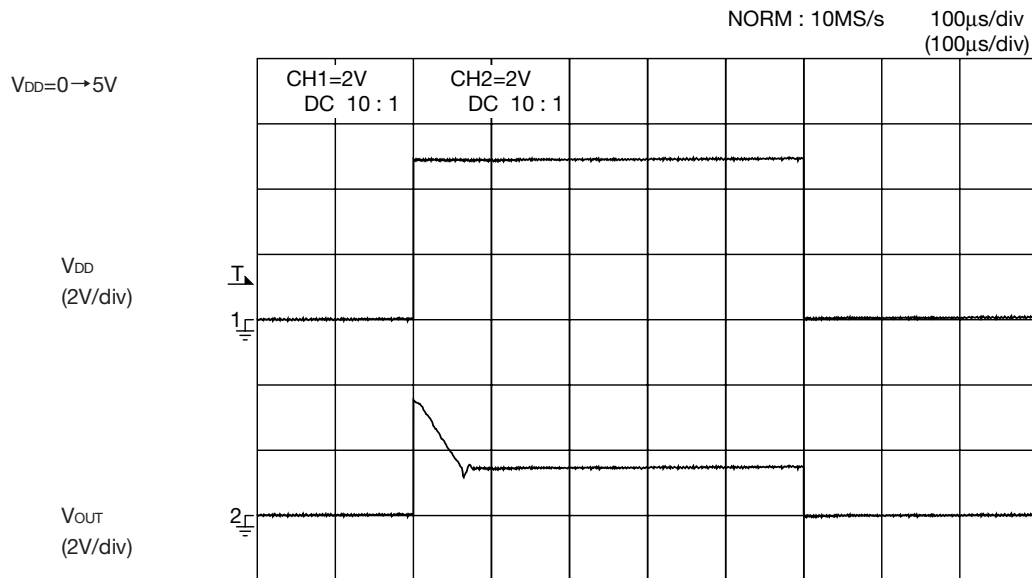
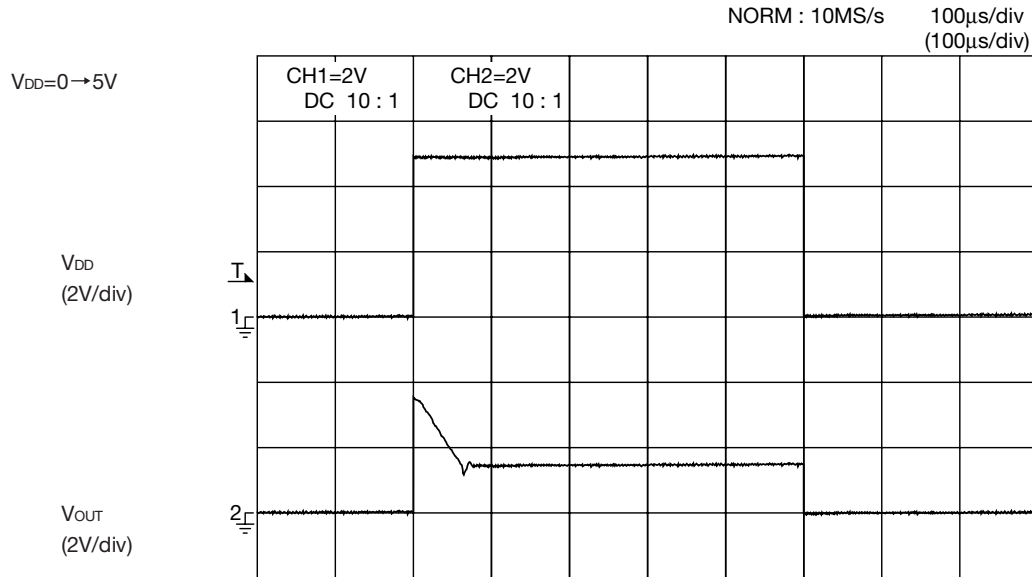

■ Thermal response characteristic in the air at 25°C → in the air at 100°C

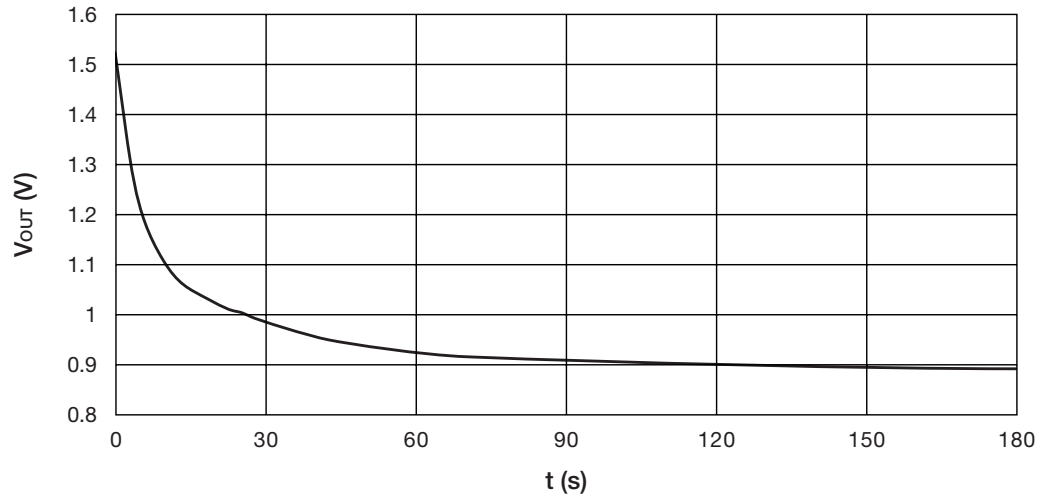

■ Thermal response characteristic in the air at 25°C → in the liquid at 100°C

