

FLZ2V2 - FLZ39V

Zener Diodes



SOD-80 Glass case
Color Band Denotes Cathode

Color Band Marking		
Tolerance	1st Band	2nd Band
A	Blue	Red
B	Blue	Green
C	Blue	Black
D	Blue	Gray

Absolute Maximum Ratings T_a = 25°C unless otherwise noted

Symbol	Parameter	Value	Units
P _D	Power Dissipation	500	mW
T _{STG}	Storage Temperature Range	-65 to +175	°C
T _J	Maximum Junction Temperature	175	°C
I _{ZM}	Maximum Regulator Current	P _D /V _Z	mA

* These ratings are limiting values above which the serviceability of the diode may be impaired.

Thermal Characteristics

Symbol	Parameter	Value	Unit
R _{θJA}	Thermal Resistance, Junction to Ambient	300	°C/W

* Device mounted on FR-4 PCB with 3" × 4.5" X 0.06 with only signal trace

Electrical Characteristics T_{amb} = 25°C unless otherwise specified

Symbol	Parameter/ Test condition	Min.	Typ.	Max.	Unit
V _F	Forward Voltage / I _F =200mA	--	--	1.2	V

Package Marking and Ordering Information

Device Marking	Device	Package	Reel Size	Tape Width	Quantity
Color Band Marking Per Tolerance	Refer to Product table list	SOD-80	7"	8mm	2,500

Electrical Characteristics T_A=25°C unless otherwise noted

Product Group	Product Name	V _Z (V) @ I _{ZT}			Z _{ZT} (Ω) @ I _{ZT}	I _{ZT} (mA)	Z _{ZK} (Ω) @ I _{ZK}	I _{ZK} (mA)	I _R (μA) @ V _R	V _R (V)
		Min.	Typ.	Max.	Max.	-	Max.	-	Max.	-
FLZ2V2	FLZ2V2A	2.13	2.21	2.29	35	20	400	1	55	0.7
	FLZ2V2B	2.23	2.32	2.40	35	20	400	1	55	0.7
FLZ2V4	FLZ2V4A	2.34	2.42	2.50	35	20	400	1	84	1
	FLZ2V4B	2.45	2.53	2.61	35	20	400	1	84	1
FLZ2V7	FLZ2V7A	2.55	2.64	2.73	35	20	450	1	70	1
	FLZ2V7B	2.70	2.80	2.90	35	20	450	1	70	1
FLZ3V0	FLZ3V0A	2.86	2.96	3.05	35	20	450	1	35	1
	FLZ3V0B	3.02	3.12	3.21	35	20	450	1	35	1
FLZ3V3	FLZ3V3A	3.17	3.27	3.36	35	20	450	1	14	1
	FLZ3V3B	3.33	3.43	3.52	35	20	450	1	14	1
FLZ3V6	FLZ3V6A	3.48	3.57	3.66	48	20	850	1	2.8	1
	FLZ3V6B	3.64	3.73	3.81	48	20	850	1	2.8	1
FLZ3V9	FLZ3V9A	3.78	3.88	3.97	40	20	850	1	1.4	1
	FLZ3V9B	3.93	4.03	4.12	40	20	850	1	1.4	1
FLZ4V3	FLZ4V3A	4.07	4.15	4.23	32	20	850	1	0.47	1
	FLZ4V3B	4.22	4.30	4.38	32	20	850	1	0.47	1
	FLZ4V3C	4.35	4.44	4.52	32	20	850	1	0.47	1
FLZ4V7	FLZ4V7A	4.48	4.56	4.64	21	20	770	1	0.19	1
	FLZ4V7B	4.60	4.68	4.75	21	20	770	1	0.19	1
	FLZ4V7C	4.73	4.81	4.89	21	20	770	1	0.19	1
FLZ5V1	FLZ5V1A	4.86	4.94	5.02	17	20	685	1	0.19	1.5
	FLZ5V1B	4.99	5.08	5.16	17	20	685	1	0.19	1.5
	FLZ5V1C	5.13	5.23	5.33	17	20	685	1	0.19	1.5
FLZ5V6	FLZ5V6A	5.31	5.41	5.50	10.5	20	425	1	0.75	2.5
	FLZ5V6B	5.48	5.58	5.68	10.5	20	425	1	0.75	2.5
	FLZ5V6C	5.66	5.76	5.86	10.5	20	425	1	0.75	2.5
FLZ6V2	FLZ6V2A	5.83	5.94	6.04	8.5	20	255	1	3.3	3
	FLZ6V2B	6.01	6.12	6.22	8.5	20	255	1	3.3	3
	FLZ6V2C	6.18	6.28	6.38	8.5	20	255	1	3.3	3
FLZ6V8	FLZ6V8A	6.33	6.45	6.57	6.6	20	123	0.5	1.1	3.5
	FLZ6V8B	6.54	6.66	6.77	6.6	20	123	0.5	1.1	3.5
	FLZ6V8C	6.72	6.83	6.93	6.6	20	123	0.5	1.1	3.5
FLZ7V5	FLZ7V5A	6.90	7.04	7.17	6.6	20	95	0.5	0.3	4.0
	FLZ7V5B	7.13	7.26	7.39	6.6	20	95	0.5	0.3	4.0
	FLZ7V5C	7.35	7.49	7.62	6.6	20	95	0.5	0.3	4.0
FLZ8V2	FLZ8V2A	7.58	7.73	7.88	6.6	20	95	0.5	0.3	5
	FLZ8V2B	7.84	7.99	8.13	6.6	20	95	0.5	0.3	5
	FLZ8V2C	8.09	8.24	8.39	6.6	20	95	0.5	0.3	5
FLZ9V1	FLZ9V1A	8.34	8.51	8.68	6.6	20	95	0.5	0.3	6
	FLZ9V1B	8.63	8.80	8.97	6.6	20	95	0.5	0.3	6
	FLZ9V1C	8.91	9.09	9.27	6.6	20	95	0.5	0.3	6

Electrical Characteristics (Continued) $T_A=25^\circ\text{C}$ unless otherwise noted

Product Group	Product Name	V_Z (V) @ I_{ZT}			$Z_{ZT}(\Omega)$ @ I_{ZT}	I_{ZT} (mA)	$Z_{ZK}(\Omega)$ @ I_{ZK}	I_{ZK} (mA)	$I_R(\mu\text{A})$ @ V_R	V_R (V)
		Min.	Typ.	Max.	Max.	-	Max.	-	Max	-
FLZ10V	FLZ10VA	9.21	9.39	9.57	6.6	20	95	0.5	0.11	7
	FLZ10VB	9.50	9.69	9.88	6.6	20	95	0.5	0.11	7
	FLZ10VC	9.84	10.06	10.28	6.6	20	95	0.5	0.11	7
FLZ11V	FLZ11VA	10.2	10.41	10.61	8.5	10	95	0.5	0.133	8
	FLZ11VB	10.53	10.73	10.92	8.5	10	95	0.5	0.133	8
	FLZ11VC	10.85	11.04	11.23	8.5	10	95	0.5	0.133	8
FLZ12V	FLZ12VA	11.16	11.38	11.60	9.5	10	95	0.5	0.133	9
	FLZ12VB	11.53	11.71	11.89	9.5	10	95	0.5	0.133	9
	FLZ12VC	11.83	12.05	12.27	9.5	10	95	0.5	0.133	9
FLZ13V	FLZ13VA	12.21	12.45	12.68	11.4	10	95	0.5	0.133	10
	FLZ13VB	12.62	12.87	13.12	11.4	10	95	0.5	0.133	10
	FLZ13VC	13.07	13.33	15.38	11.4	10	95	0.5	0.133	10
FLZ15V	FLZ15VA	13.52	13.79	14.05	13.3	10	95	0.5	0.133	11
	FLZ15VB	13.99	14.26	14.52	13.3	10	95	0.5	0.133	11
	FLZ15VC	14.45	14.72	14.99	13.3	10	95	0.5	0.133	11
FLZ16V	FLZ16VA	14.90	15.19	15.47	15.2	10	132	0.5	0.133	12
	FLZ16VB	15.36	15.65	15.93	15.2	10	132	0.5	0.133	12
	FLZ16VC	15.83	16.14	16.45	15.2	10	132	0.5	0.133	12
FLZ18V	FLZ18VA	16.38	16.70	17.02	19.4	10	123	0.5	0.133	13
	FLZ18VB	16.96	17.29	17.61	19.4	10	123	0.5	0.133	13
	FLZ18VC	17.56	17.90	18.24	19.4	10	123	0.5	0.133	13
FLZ20V	FLZ20VA	18.17	18.52	18.86	23.5	10	170	0.5	0.133	15
	FLZ20VB	18.78	19.13	19.48	23.5	10	170	0.5	0.133	15
	FLZ20VC	19.42	19.80	20.18	23.5	10	170	0.5	0.133	15
	FLZ20VD	19.93	20.30	20.67	23.5	10	170	0.5	0.133	15
FLZ22V	FLZ22VA	20.28	20.66	21.03	25.6	5	170	0.5	0.133	17
	FLZ22VB	20.82	21.21	21.59	25.6	5	170	0.5	0.133	17
	FLZ22VC	21.29	21.66	22.02	25.6	5	170	0.5	0.133	17
	FLZ22VD	21.75	22.15	22.54	25.6	5	170	0.5	0.133	17
FLZ24V	FLZ24VA	22.32	22.69	23.06	29.0	5	170	0.5	0.133	19
	FLZ24VB	22.81	23.24	23.67	29.0	5	170	0.5	0.133	19
	FLZ24VC	23.35	23.78	24.21	29.0	5	170	0.5	0.133	19
	FLZ24VD	23.87	24.31	24.75	29.0	5	170	0.5	0.133	19
FLZ27V	FLZ27VA	24.33	24.89	25.45	38	5	210	0.5	0.133	21
	FLZ27VB	25.04	25.62	26.19	38	5	210	0.5	0.133	21
	FLZ27VC	25.69	26.29	26.88	38	5	210	0.5	0.133	21
	FLZ27VD	26.36	26.97	27.57	38	5	210	0.5	0.133	21
FLZ30V	FLZ30VA	27.07	27.69	28.31	46	5	210	0.5	0.133	23
	FLZ30VB	27.77	28.41	29.05	46	5	210	0.5	0.133	23
	FLZ30VC	28.44	29.09	29.74	46	5	210	0.5	0.133	23
	FLZ30VD	29.10	29.77	30.43	46	5	210	0.5	0.133	23

Product Group	Product Name	V _Z (V) @ I _{ZT}			Z _{ZT} (Ω) @ I _{ZT}	I _{ZT} (mA)	Z _{ZK} (Ω) @ I _{ZK}	I _{ZK} (mA)	I _R (μA) @ V _R	V _R (V)
		Min.	Typ.	Max.	Max.	-	Max.	-	Max	-
FLZ33V	FLZ33VA	29.76	30.45	31.14	55	5	210	0.5	0.133	25
	FLZ33VB	30.40	31.10	31.80	55	5	210	0.5	0.133	25
	FLZ33VC	30.99	31.70	32.41	55	5	210	0.5	0.133	25
	FLZ33VD	31.57	32.30	33.03	55	5	210	0.5	0.133	25
FLZ36V	FLZ36VA	32.30	32.96	33.62	63	5	210	0.5	0.133	27
	FLZ36VB	32.95	33.63	34.30	63	5	210	0.5	0.133	27
	FLZ36VC	33.58	34.27	34.95	63	5	210	0.5	0.133	27
	FLZ36VD	34.19	34.89	35.59	63	5	210	0.5	0.133	27
FLZ39V	FLZ39VA	34.86	35.57	36.28	72	5	210	0.5	0.133	30
	FLZ39VB	35.53	36.26	36.99	72	5	210	0.5	0.133	30
	FLZ39VC	36.18	36.92	37.66	72	5	210	0.5	0.133	30
	FLZ39VD	36.82	37.58	38.33	72	5	210	0.5	0.133	30

Note :

1. Zener Voltage(V_Z)

The zener voltage is measured with the device junction in the thermal equilibrium at the lead temperature (TL) at at 30°C ± 1°C and 3/8" lead length.

Typical Performance Characteristics

Figure 1. Zener current vs. Zener Voltage

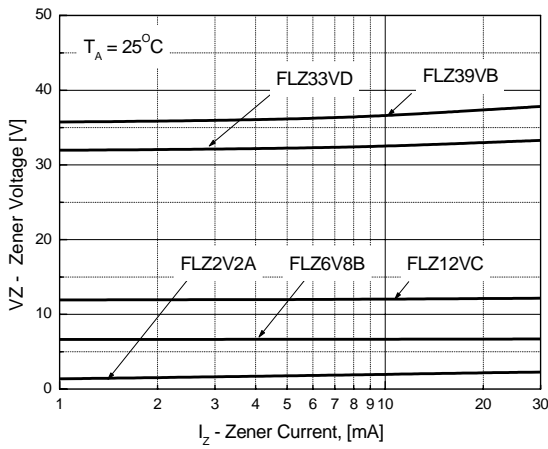

Figure 2. Zener current vs. Zener Impedance

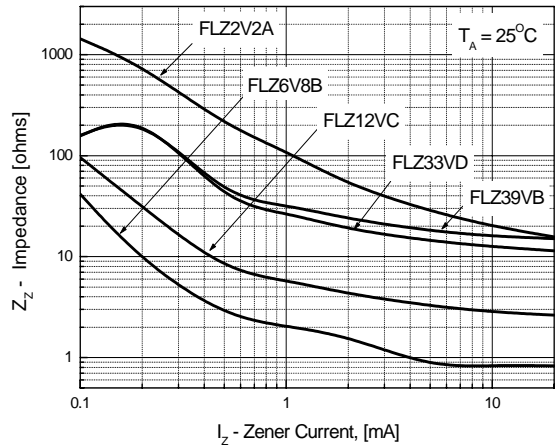

Figure 3. FLZ2V2A
Zener current vs. Zener Voltage

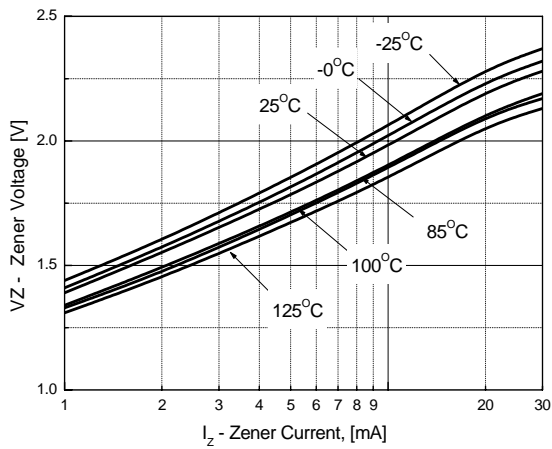

Figure 4. FLZ6V8B
Zener current vs. Zener Voltage

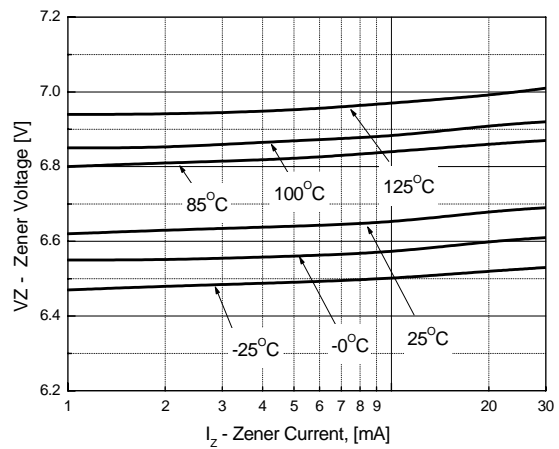

Figure 5. FLZ12VC
Zener current vs. Zener Voltage

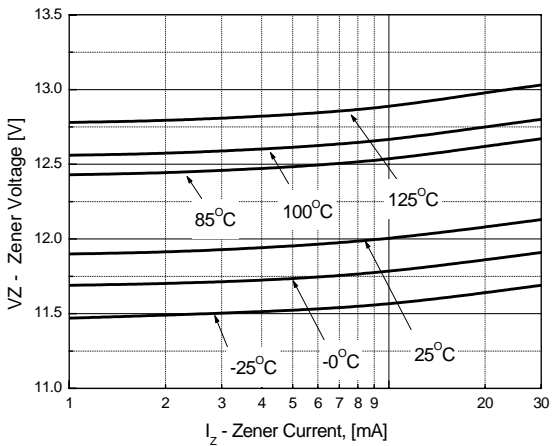
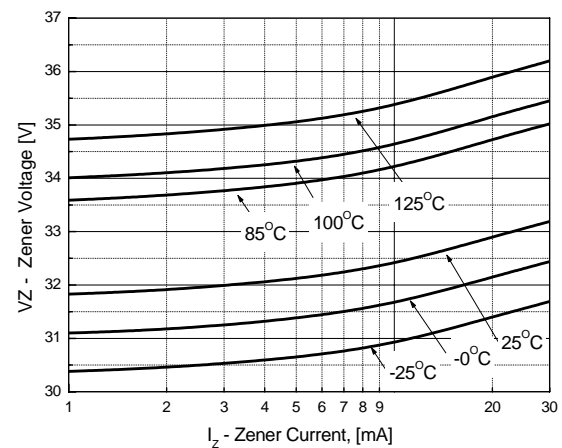
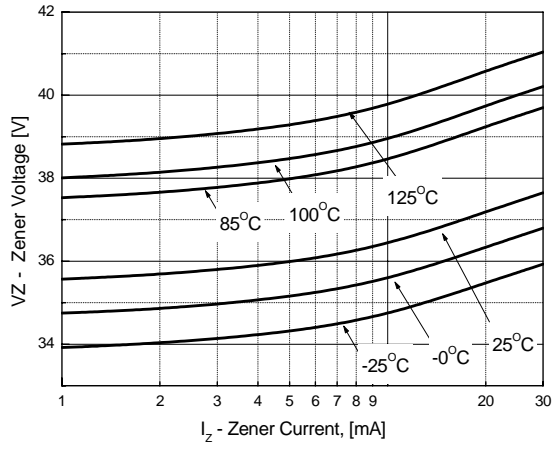

Figure 6. FLZ33VD
Zener current vs. Zener Voltage



Typical Performance Characteristics

Figure 9. FLZ39VB
Zener current vs. Zener Voltage



Mechanical Dimensions

SOD-80

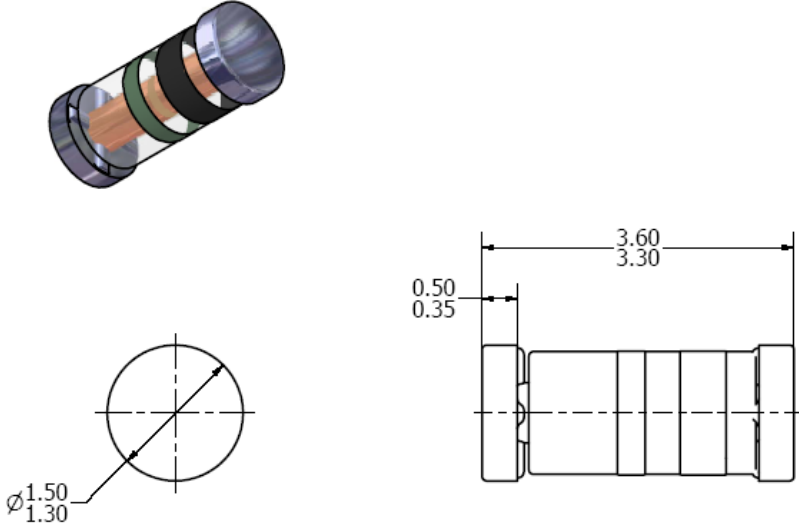

Dimensions in Millimeters

TRADEMARKS

The following are registered and unregistered trademarks Fairchild Semiconductor owns or is authorized to use and is not intended to be an exhaustive list of all such trademarks.

ACEx™	FACT Quiet Series™	OCX™	SILENT SWITCHER®	UltraFET®
ActiveArray™	GlobalOptoisolator™	OCXPro™	SMART START™	UniFET™
Bottomless™	GTO™	OPTOLOGIC®	SPM™	VCX™
Build it Now™	HiSeC™	OPTOPLANAR™	Stealth™	Wire™
CoolFET™	I ² C™	PACMAN™	SuperFET™	
CROSSVOLT™	i-Lo™	POP™	SuperSOT™-3	
DOME™	ImpliedDisconnect™	Power247™	SuperSOT™-6	
EcoSPARK™	IntelliMAX™	PowerEdge™	SuperSOT™-8	
E ² CMOS™	ISOPLANAR™	PowerSaver™	SyncFET™	
EnSigna™	LittleFET™	PowerTrench®	TCM™	
FACT™	MICROCOUPLER™	QFET®	TinyBoost™	
FAST®	MicroFET™	QS™	TinyBuck™	
FASTr™	MicroPak™	QT Optoelectronics™	TinyPWM™	
FPST™	MICROWIRE™	Quiet Series™	TinyPower™	
FRFET™	MSX™	RapidConfigure™	TinyLogic®	
	MSXPro™	RapidConnect™	TINYOPTO™	
Across the board. Around the world.™		μSerDes™	TruTranslation™	
The Power Franchise®		ScalarPump™	UHC™	
Programmable Active Droop™				

DISCLAIMER

FAIRCHILD SEMICONDUCTOR RESERVES THE RIGHT TO MAKE CHANGES WITHOUT FURTHER NOTICE TO ANY PRODUCTS HEREIN TO IMPROVE RELIABILITY, FUNCTION OR DESIGN. FAIRCHILD DOES NOT ASSUME ANY LIABILITY ARISING OUT OF THE APPLICATION OR USE OF ANY PRODUCT OR CIRCUIT DESCRIBED HEREIN; NEITHER DOES IT CONVEY ANY LICENSE UNDER ITS PATENT RIGHTS, NOR THE RIGHTS OF OTHERS. THESE SPECIFICATIONS DO NOT EXPAND THE TERMS OF FAIRCHILD'S WORLDWIDE TERMS AND CONDITIONS, SPECIFICALLY THE WARRANTY THEREIN, WHICH COVERS THESE PRODUCTS.

LIFE SUPPORT POLICY

FAIRCHILD'S PRODUCTS ARE NOT AUTHORIZED FOR USE AS CRITICAL COMPONENTS IN LIFE SUPPORT DEVICES OR SYSTEMS WITHOUT THE EXPRESS WRITTEN APPROVAL OF FAIRCHILD SEMICONDUCTOR CORPORATION.

As used herein:

- Life support devices or systems are devices or systems which, (a) are intended for surgical implant into the body, or (b) support or sustain life, or (c) whose failure to perform when properly used in accordance with instructions for use provided in the labeling, can be reasonably expected to result in significant injury to the user.
- A critical component is any component of a life support device or system whose failure to perform can be reasonably expected to cause the failure of the life support device or system, or to affect its safety or effectiveness.

PRODUCT STATUS DEFINITIONS

Definition of Terms

Datasheet Identification	Product Status	Definition
Advance Information	Formative or In Design	This datasheet contains the design specifications for product development. Specifications may change in any manner without notice.
Preliminary	First Production	This datasheet contains preliminary data, and supplementary data will be published at a later date. Fairchild Semiconductor reserves the right to make changes at any time without notice in order to improve design.
No Identification Needed	Full Production	This datasheet contains final specifications. Fairchild Semiconductor reserves the right to make changes at any time without notice in order to improve design.
Obsolete	Not In Production	This datasheet contains specifications on a product that has been discontinued by Fairchild semiconductor. The datasheet is printed for reference information only.

Rev. I20