



- Up to 350W output
- Up to 6 outputs
- Voltages up to 28V, Current up to 50 Amps
- Fast-on output connection
- Worldwide approvals
- 3 Year Warranty

# Sirius

250 & 350 Watts Single and Multi Output

## Key Market Segments & Applications

- |                             |                         |
|-----------------------------|-------------------------|
| Instrumentation             | Broadcast               |
| Medical                     | ATE                     |
| Automation                  | Industrial Computing    |
| Security                    | Lifesciences/Laboratory |
| Network Servers and Routers |                         |

INPUT	
Input Voltage	85 - 264Vac, 120 - 340Vdc (120 - 360Vdc for CSF350)
Input Frequency	47 - 440Hz
Inrush Current	<25A at 25°C and 264Vac (cold start) (<40A for CS250 and CSF250)
Input Fuse	250Vac HBC Fast Acting (not user accessible) 6.3A for 250W, 10A for 600W
Leakage Current	0.8mA max at 264Vac & 50Hz
Lower Leakage Option	see configuring guide
Power Factor	>0.93 typical (reduced pfc above 254Vac or >65Hz)

OUTPUT		
Voltage / Current	See module output table	
Switching Frequency	110kHz - PFC converter, 190kHz - Output converter	
Efficiency	>70%	typical, config dependent
Ripple	1%	(50mV on 3V outputs)
Noise	<1%	Pk- Pk, using EIAJ test method & 20MHz bandwidth. (For 3V and 5V main output, 2% pk-pk or 50mV)
Voltage Accuracy	<1%	of set Voltage
Remote Sense	Yes	0.5V on all main board outputs and L and A modules
Minimum Load	No	on any output for CSF250 and CSF350. (10% on output 1 for full spec on CS250)
Temperature Coefficient	<0.02%	of rated voltage per °C
Total Regulation	3% or 50mV	whichever is greater
Peak Current	max 150%	1 sec in 10 on o/p 2 and all modules >9V
Over Voltage Protection	Standard	for all outputs, shuts down converter, auto restarts
Over Current Protection	Standard	all outputs short circuit protected (with auto-recovery)
Short Circuit Protection	<150%	of rated current, when output voltage <1%
Over Temperature Protection	Yes	on converter and output regulators (with auto recovery)
Note shutdown temp varies according to ambient, output power and input V		

SAFETY APPROVALS					
	Date	Amendments		Date	Amendments
EN 60950-1*	2001		CSA22.2 No 60950-1	2003	
UL 60950-1	2003		IEC60950-1*	2001	
* CB Certificate and report available on request			CE Mark	LV Directive 73/23/EEC (EN60950-1:2001)	

EMISSIONS EN61000-6-3:2001			
Radiated Electric Field	EN55022	Class B (as per CISPR.22)	See application note for details.
Conducted Emissions	EN55022	Class B (as per CISPR.22)	
Conducted Harmonics	EN61000-3-2: 2001	Compliant to Class A	
Flicker	EN61000-3-3: 1995 + A1:2001	Compliant - $d_{max}$ only.	

IMMUNITY EN61000-6-2:2001				
				Criteria
Electrostatic Discharge	EN61000-4-2: 1995	Level 4	Air discharge 15kV Contact discharge 8kV	A
Electromagnetic Field	EN61000-4-3: 2002	Level 3	10V/m (tested to 12V/m)	A
Fast / Burst Transient	EN61000-4-4: 2004	Level 4	Input 4kV Outputs 2kV, Tested at 5kHz	A
Surge Immunity	EN61000-4-5: 1995	Level 3	Line to Line 2kV Line to Earth 1kV	A
Conducted RF Immunity	EN61000-4-6: 1996	Level 3	10V (tested to 12V)	A
Power Frequency Magnetic Field	EN61000-4-8: 1994	Level 3	10A/m Continuous	A
Voltage Dips, Variation, Interruptions	EN61000-4-11: 1995	Pass		A B for 5s interruptions
Voltage Fluctuations	EN61000-4-14: 1999 + A1: 2004	Class 3	For 100 to 240V nominal	A

ENVIRONMENT	
Temperature	0°C to 70°C operational, -40° to 85°C storage (max 12 months). IEC input connector max rating 65°C (EI and SI models)
Derating	50°C to 70°C derate each output by 2.5% per °C
Humidity	5-95% RH non condensing
Shock	3000 shocks, each of 10g (16ms) half sine
Vibration	10 - 200Hz @ 1.5g
Altitude	3,000 metres operational (2,000 metres CS250 and CSF250)
Pollution	Degree 2, Material group 3
IP Rating	IP 10
Weight	1.27 kg

ISOLATION					
Input to Output	Reinforced	4.3 kV (dc)	Output to Earth	Operational	500 V (dc)
Input to Earth	Basic	2.3 kV (dc)	Output to Output	Operational	500 V (dc)

OUTPUT VOLTAGES (Outputs 1 and 2, main board outputs)						
Unit Type	Outputs 1 and 2	V1 Adjustment Range (Volts)	Amps	V2 Adjustment Range (Volts)	Amps	Notes
CS250	5/3.3	5 - 5.5 <sub>a</sub>	35	2.7 - 3.5 <sub>b</sub>	16 <sub>c</sub>	These outputs have common 0V
	5/12	5 - 5.5 <sub>a</sub>	35	9 - 15	8	These outputs have common 0V
	24	24 - 28	10	-	-	
CSF250	3.3/5	1.8 - 3.8	30	4.5 - 5.5 <sub>a</sub>	20	These outputs have common 0V
	5/12	4.5 - 8.0	25	9 - 13	10	
	5/24	4.5 - 8.0	25	18 - 25	6	
CSF350	5/3.3	3.9 - 5.7	50 <sub>e</sub>	1.8 - 3.9	20	These outputs have common 0V
	3.3/5	1.8 - 3.9	50 <sub>f</sub>	3.9 - 5.7	20	These outputs have common 0V
	3.3/12	1.8 - 3.9	50 <sub>d</sub>	10 - 16	12	
	5/12	3.9 - 5.7	50 <sub>d</sub>	10 - 16	12	
	24	18 - 28	15	-	-	
<b>Notes:</b> all voltages in this table include sense voltage (total line drop) unless otherwise stated all outputs galvanically isolated unless otherwise stated a - maximum voltage at terminals = 5.7V b - maximum voltage at terminals = 3.8V c - max current from output 2 must not exceed 2 x current from output 1 d - 45A above 40°C ambient e - 45A above 35°C ambient, 40A above 45°C f - 45A above 45°C ambient						

OUTPUTS 3-6 (Single Output Modules)				(twin output modules)				
Unit Type	Module	Adjustment Range (Volts)	Amps <sub>c</sub>	Module	V1 Adjustment Range (Volts)	Amps <sub>c</sub>	V2 Adjustment Range (Volts)	Amps
CS250	L	1.8 - 3.9 <sub>b</sub>	10 (15)	D <sub>d</sub>	4.5 - 5.5	5 (7.5)	2.7 - 3.9	5 (7.5)
	A	4.5 - 5.5 <sub>b</sub>	10 (15)	M	4.5 - 5.5	5 (7.5)	4.5 - 5.5	5 (7.5)
	B	11 - 15	8 (12)	E	4.5 - 5.5	5 (7.5)	9 - 15	4 (6)
	C	16 - 28	4 (6)	F	4.5 - 5.5	5 (7.5)	16 - 28	2 (3)
				G	9 - 15	4 (6)	9 - 15	4 (6)
				H	9 - 15	4 (6)	16 - 28	2 (3)
				J	16 - 28	2 (3)	16 - 28	2 (3)
CSF250	L	1.8 - 3.8 <sub>b</sub>	14	D <sub>d</sub>	4.5 - 6	5 (7.5)	2.7 - 4	5 (7.5)
	A	4.5 - 6 <sub>b</sub>	10 (15)	M	4.5 - 6	5 (7.5)	4.5 - 6	5 (7.5)
	B	9 - 16	8 (12)	E	4.5 - 6	5 (7.5)	9 - 16	4 (6)
	C	17 - 30	4 (6)	F	4.5 - 6	5 (7.5)	17 - 30	2 (3)
				G	9 - 16	4 (6)	9 - 16	4 (6)
				H	9 - 16	4 (6)	17 - 30	2 (3)
				J	17 - 30	2 (3)	17 - 30	2 (3)
CSF350	L	1.8 - 3.5 <sub>b</sub>	16 (24)	D <sub>d</sub>	4.5 - 5.5	6 (9)	2.7 - 3.9	6 (9)
	A	4.5 - 5.5 <sub>b</sub>	12 (18)	M	4.5 - 5.5	6 (9)	4.5 - 5.5	6 (9)
	B	9 - 15	9.5 (14.25)	E	4.5 - 5.5	6 (9)	9 - 15	4.5 (6.75)
	C	16 - 28	4.5 (6.75)	F	4.5 - 5.5	6 (9)	16 - 28	2.5 (3.75)
				G	9 - 15	4.5 (6.75)	9 - 15	4.5 (6.75)
				H	9 - 15	4.5 (6.75)	16 - 28	2.5 (3.75)
				J	16 - 28	2.5 (3.75)	16 - 28	2.5 (3.75)

**Notes:**  
a - all module outputs are isolated  
b - will allow 0.5V remote sense (total line drop), but will not adjust above specified range  
c - values for 'Amps' in brackets are peak values  
d - D module outputs have common 0V

Sirius Configuring Guide

With our Sirius range of power supplies, it possible to achieve many combinations of Volts and Amps. For the optimum configuration, please contact our sales office. However you can also create your own configuration from this datasheet by using the guide below.

Configuring from Datasheet

- Select main outputs 1 and 2 from table on page 2. Calculate total output power to determine CS250 or CSF350 then select required Cooling and Leakage Current from the following table:-

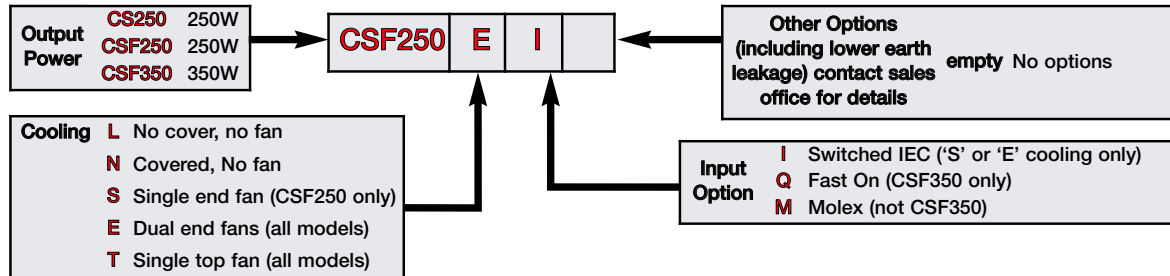

- Select Output Modules and Options from the Output Voltages tables.

Example - if you require 5.2V / 12A on a CSF350 :-

- select A as closest match for voltage and current and prefix with voltage (eg **5.2A**)
- repeat for other outputs

Ensure that the no more than 2 modules are selected. For example:-

**CSF350E15/12 3.3L 5/12E** which represents a five output 350W Sirius with End fan, IEC inlet with:-

- Output 1 = 5V / 50A
- Output 2 = 12V / 12A
- Output 3 = 3.3V / 16A (24A peak)
- Output 4 = 5V / 6A (9A peak)
- Output 5 = 12V / 4.5A (6.75A peak)

- Contact Lambda to validate configuration and issue a part number.

### Typical Terminal Layout

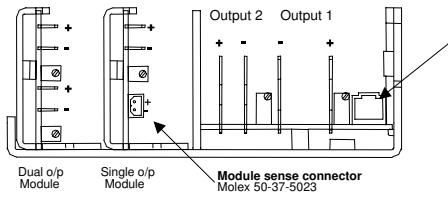

### Output Connections

All types 6.35mm 'fast on' connectors

#### Input Connection (case type dependant)

- 1) 6.35mm Faston. Input connectors also available
- 2) IEC320 connector
- 3) Molex 3069 series with locking ramp
  - 1 x 5 way housing ref 09-91-0500
  - 3 x 2478 series terminals ref 08-52-0071 or 08-52-0072

### Mechanical Drawings

All dimensions in mm unless otherwise stated. General tolerance  $\pm 0.5$ .  
Air direction on all types is from outside of fan into power supply

### Sense + signals (CSF250 & CSF350 Versions)

Molex 8 way 90142-0008 + 8 x terminals 90119-2109  
1 signal return    2 inhibit            3 ac fail/Reset    4 o/p 2 -sense  
5 ac good/Reset    6 o/p 2 +sense    7 o/p 1 -sense    8 o/p 1 +sense

#### Inhibit

TTL Low or contact closure to 'signal return'

#### AC Fail (high on fail)

5V TTL compatible output referenced to 'signal return'. 20mA max source current.

#### AC Good (low on fail)

5V TTL compatible output referenced to 'signal return'. 20mA max sink current.

### Standard Sirius (CS250) versions:-

Molex 6 way 90142-0006 + 6 x terminals 90119-2109  
1 inhibit            2 ac fail            3 o/p 2 -sense  
4 o/p 2 +sense    5 o/p 1 -sense    6 o/p 1 +sense

#### Inhibit

TTL Low or contact closure to 'o/p 1 -ve'

#### AC Fail (high on fail)

Open collector ref to 'o/p 1 -ve', turns off on fail, max 40V 50mA

### End Fan, case types EQ (Faston input) and EI (Switched IEC Inlet) (CSF350 Versions)

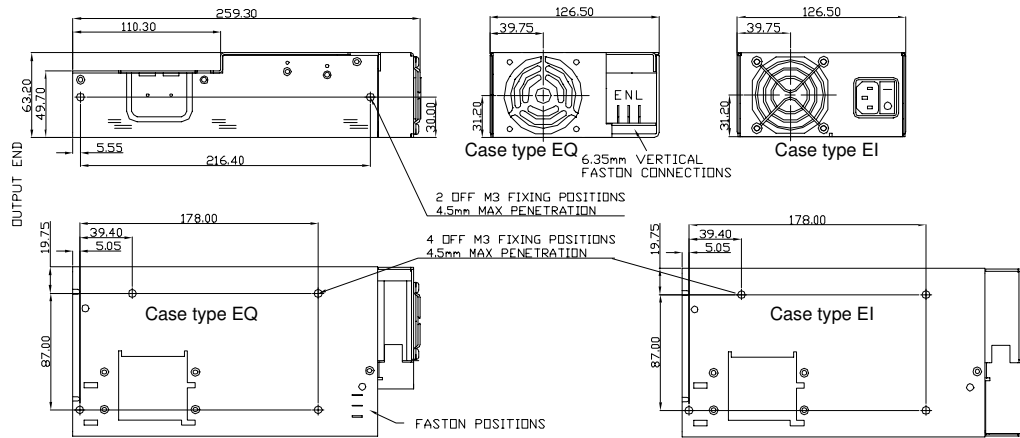

### Faston AC input, case types TQ (top fan), NQ (no fan, with cover), LQ (no fan, no cover) (CSF350 Versions)

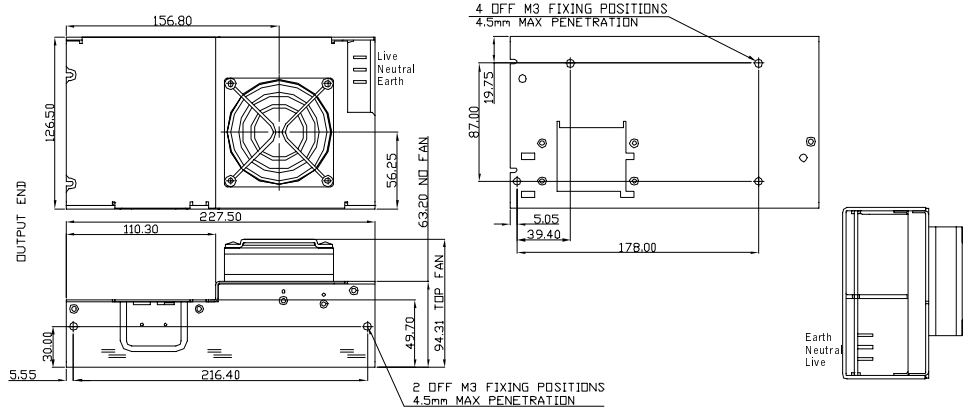

Molex inlet, case types TM (Top fan), NM (No fan, with cover), LM (No fan, no cover) (CS250 and CSF250 Versions)

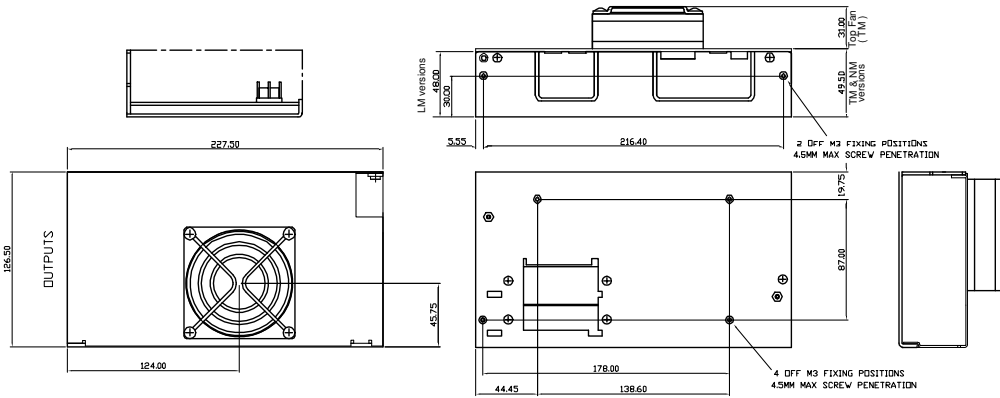

End Fan, case types EI (Switched IEC inlet) and EM (Molex inlet) (CS250 and CSF250 Versions)

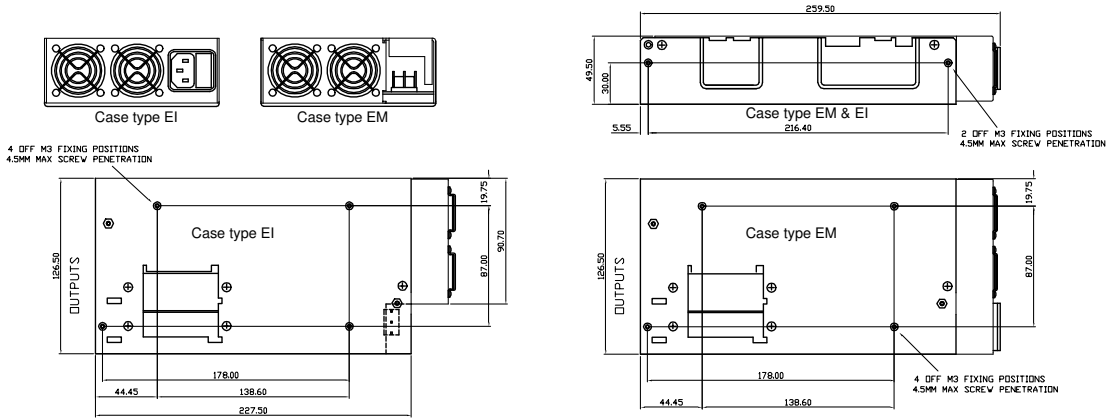

Single End Fan, case types SI (Switched IEC inlet) and SM (Molex inlet) (CSF250 Versions)

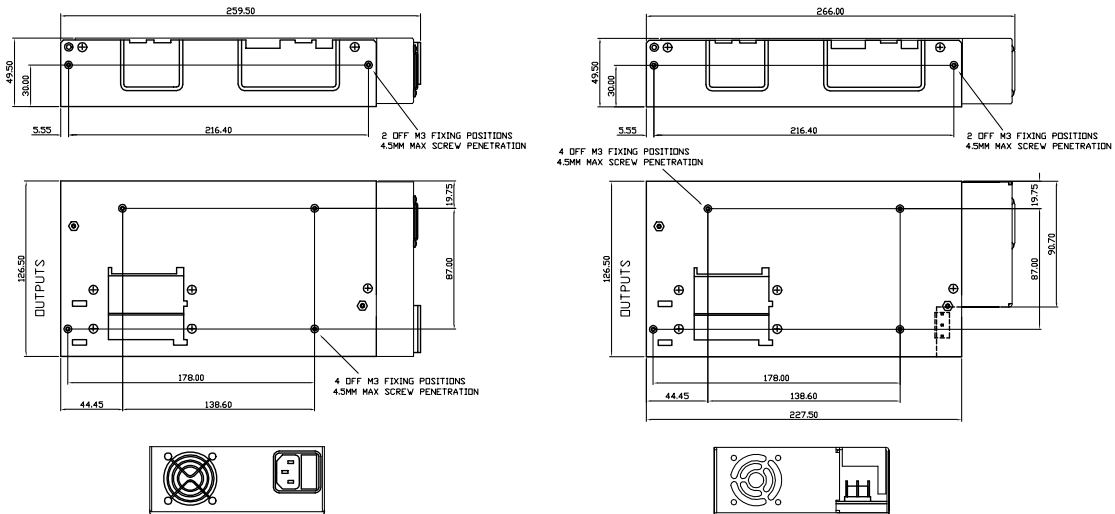

## LAMBDA EMEA

### AUSTRIA

LAMBDA ELECTRONICS GmbH  
Aredstraße 22  
A-2544 Leobersdorf

Telephone: +43 (0) 2256 655 84  
Facsimile: +43 (0) 2256 645 12  
Web: [www.lambda-austria.com](http://www.lambda-austria.com)

### FRANCE

LAMBDA SAS  
ZAC des Delaches, BP1077 - Gometz le Chatel  
91940 Les Ulis

Telephone: +33 (0) 1 60 12 71 65  
Facsimile: +33 (0) 1 60 12 71 66  
Web: [www.lambda-f.com](http://www.lambda-f.com)

### GERMANY

LAMBDA GmbH  
Karl-Bold-Straße 40  
D-77855 Achern

Telephone: +49 (0) 78 41 666 0  
Facsimile: +49 (0) 78 41 5000  
Web: [www.lambda-germany.com](http://www.lambda-germany.com)

### ISRAEL

NEMIC LAMBDA LTD  
Kibbutz Givat  
Hashlosa 48800

Telephone: +972 (0) 3 902 4333  
Facsimile: +972 (0) 3 902 4777  
Web: [www.nemic.co.il](http://www.nemic.co.il)

### ITALY

LAMBDA s.r.l.  
Via dei Lavoratori 128/130,  
20092, Cinisello Balsamo (Mi)

Telephone: +39 (0) 02 61 29 38 63  
Facsimile: +39 (0) 02 61 29 09 00  
Web: [www.lambda-italy.com](http://www.lambda-italy.com)

### SWEDEN

LAMBDA SCANDINAVIA  
PO Box 546, Rallervägen 41  
SE-184 25. Åkersberga

Telephone: +46 (0) 8 598 94 090  
Facsimile: +46 (0) 8 540 66 096  
Web: [www.lambda-scandinavia.com](http://www.lambda-scandinavia.com)

### UK

LAMBDA UK  
Kingsley Avenue  
Ilfracombe Devon EX34 8ES

Telephone: +44 (0) 1271 856666  
Facsimile: +44 (0) 1271 864894  
Web: [www.lambda-gb.com](http://www.lambda-gb.com)

## LAMBDA NORTH AMERICA

visit [www.lambda-power.com](http://www.lambda-power.com) for a list of Lambda offices and distributors

## LAMBDA ASIA

visit [www.densei-lambda.com](http://www.densei-lambda.com) for a list of Lambda offices and distributors

## LOCAL DISTRIBUTION